

UNIVERSITY OF CALIFORNIA RIVERSIDE

Please consult with Campus Architect or
Campus Physical Planner prior to specifying
signage.

Not all sign types herein are still considered
standards.

Campus logo and specifications for standard
colors (blue and gold) will change in Fall
2020.

CAMPUS SIGN PROGRAM
100% PACKAGE

Section 1: Sign Type Drawings
Section 2: Sign Location Plans
Section 3: Building Identification Survey

1.04.08

LAST UPDATED 09.15.2020

INTERIOR SIGNAGE at interior locations:
there is some latitude on the panel color and
material. See MRB submittal as an example.
Consult with Campus Architect.

- 1.1–1.44 **Section 1**
Sign Type Drawings

- 2.1–2.43 **Section 2**
Sign Location Plans

- 3.1–3.87 **Section 3**
Building Identification Sign Survey

1.1 Typefaces & Color

Electronic Message Boards

- 1.2 W10 Site ID, Freeway
- 1.3 W11 Campus ID

Campus Entry Monument

- 1.4 W15 Primary ID
- 1.5 W16 Secondary ID

Vehicular Directional

- 1.6 W20 Primary
- 1.7 W20.1 Primary, Engineering
- 1.8 W21 Secondary
- 1.9 W21.1 Secondary, Engineering
- 1.10 W22 Pole Mounted
- 1.11 W22.1 Pole Mounted, Engineering

Pedestrian Directional

- 1.12 W30 Blade Sign
- 1.13 W30.1 Blade Sign, Engineering
- 1.14 W35 Wall Mounted
- 1.15 W36 Accessible Pathway

Pedestrian Information

- 1.16 W40 Freestanding Directory, primary
- 1.17 W40.1 Freestanding Directory, primary, Engineering
- 1.18 W40.2 Freestanding Directory, primary, Engineering
- 1.19 W41 Wall Mounted Directory
- 1.20 W41.1 Wall Mounted Directory, Engineering
- 1.21 W42 Freestanding Directory, secondary
- 1.22 W42.1 Freestanding Directory, secondary Engineering
- 1.23 W42.2 Freestanding Directory, secondary Engineering
- 1.24 W46 Info Kiosk, Posted Messages
- 1.25 W46.1 Info Kiosk, Engineering
- 1.26 W46.2 Info Kiosk, Engineering
- 1.27 W48 Interactive Kiosk
- 1.28 W48.1 Interactive Kiosk

Building Identity

- 1.29 W50 Primary, Vehicular
- 1.30 W50.1 Primary, Vehicular
- 1.31 W50.2 Primary, Vehicular
- 1.32 W50.3 Primary, Vehicular, Engineering
- 1.33 W51 Freestanding, Ped
- 1.34 W51.1 Freestanding, Ped
- 1.35 W51.2 Freestanding, Ped
- 1.36 W52 Wall Mounted
- 1.37 W53 Vinyl Letters on Door
- 1.38 W54 Parapet Letters
- 1.39 W55 Building ID, small
(Refer to sheet 1.66 for Loading Dock Identification)

Parking Lot Identity & Information

- 1.40 W70 Primary ID
- 1.41 W70.1 Primary ID
- 1.42 W71 Secondary ID
- 1.43 W71.1 Secondary ID
- 1.44 W72 Pole Mounted ID
- 1.45 W72.1 Pole Mounted ID
- 1.46 W97 Street Sign

Building Interior Identity Program

- 1.47 B20 Ceiling Mounted Department Area ID
- 1.48 B22 Blade Sign ID
- 1.49 B30 Wall Mounted Changeable Room ID **ADDED B31**
- 1.50 B32 Wall Mounted Room ID (Paper Holder) **ADDED B32A**
- 1.51 B36 Wall Mounted Restroom ID (ADA)
- 1.52 B42 Wall Mounted Directional
- 1.53 B50 Wall Mounted Building Directory
- 1.54 B52 Wall Mounted Floor Directory
- 1.55 B60 Wall Mounted Secondary Information
- 1.56 B64 Wall Mounted Bulletin Board
- 1.57 B70 Wall Mounted Permanent Room ID
- 1.58 B75 Wall Mounted Evacuation Map
- 1.59 B80 Wall Mounted Restroom ID
- 1.60 B81 Wall Mounted Stair Level ID (ADA)
- 1.61 B82 Wall Mounted Stair Level ID
- 1.62 B86 Wall Mounted Maximum Occupancy
- 1.63 B90 Door Entry / Exit Information
- 1.64 B92 Wall Mounted Accessible ID
- 1.65 B94 Wall Mounted Accessible Information
- 1.66 B95 Wall Mounted Loading Dock Parking Regulatory Information



Key Plan

2.1 Overall Campus Map

Sign Location Plans:
includes the following sign types

 **Electronic Message Boards**
W10 Site ID, Freeway
W11 Campus ID

 **Campus Entry Monument**
W15 Primary ID
W16 Secondary ID

 **Pedestrian Information**
W36 Accessible Pathway

 **Pedestrian Information**
W40 Freestanding Directory, primary
W41 Wall Mounted Directory
W42 Freestanding Directory, secondary
W46 Info Kiosk, Posted Messages
W48 Interactive Kiosk

 **Building Identity**
W50 Primary, vehicular
W51 Freestanding, Ped

 **Parking Lot Id/Info**
W70 Primary ID
W71 Secondary ID
W72 Pole Mounted ID

 W97 Street Signs

- 2.2 Section A
- 2.3 Section B
- 2.4 Section C
- 2.5 Section D
- 2.6 Section E
- 2.7 Section F
- 2.8 Section G
- 2.9 Section H
- 2.10 Section I
- 2.11 Section J
- 2.12 Section K
- 2.13 Section L
- 2.14 Section M
- 2.15 Section N
- 2.16 Section O
- 2.17 Section P
- 2.18 Section R
- 2.19 Section S

Vehicular Directionals
includes the following sign types

 **Vehicular Directional**
W20 Primary
W21 Secondary
W22 Pole Mounted

- 2.20 Introduction
- 2.21 Section B
- 2.22 Section C
- 2.23 Section E
- 2.24 Section F
- 2.25 Section G
- 2.26 Section H
- 2.27 Section I
- 2.28 Section J
- 2.29 Section K
- 2.30 Section M
- 2.31 Section N
- 2.32 Section Q
- 2.33 Section R
- 2.34 Section S

Pedestrian Directionals
includes the following sign types

 **Pedestrian Directional**
W30 Blade Sign
W35 Wall Mounted

- 2.35 Introduction
- 2.36 Section E
- 2.37 Section F
- 2.38 Section H
- 2.39 Section I
- 2.40 Section J
- 2.41 Section M
- 2.42 Section N
- 2.43 Section S



A

- 3.1 Aberdeen-Inverness Residence Hall (343)
- 3.2 Agricultural Operations (489)
- 3.3 Anderson Hall 1 & 2 (325 & 357)
- 3.4 Arts Building (411)

B

- 3.5 The Barn, Theater Workshop, & Barn Stable (358)
- 3.6 Bannockburn Village *Bldgs A-V* (590–611)
- 3.7 Batchelor Hall (501 & 501a)
- 3.8 Biological Sciences (186)
- 3.9 Biomedical Teaching Complex
& Biomedical Trailers 2 & 3 (385 & 561)
- 3.10 Bookstore (224)
- 3.11 Botanical Gardens (254)
- 3.12 Bourns Hall (261)
- 3.13 Boyce Hall (341)
- 3.14 Boyden Laboratory (482)

C

- 3.15 California Museum of Photography (720) downtown
- 3.16 Campus Surge (380)
- 3.17 Canyon Crest Family Student Housing (000–183)
- 3.18 Central Utility Plant (295)
- 3.19 Chapman Hall (215)
- 3.20 Chemical Sciences (414)
- 3.21 Child Development Center A (396)
- 3.22 College Building North (517)
& College Building South (231)
- 3.23 Computing & Communications Center (381)
- 3.24 Corporation Yard A–C (485–487)
- 3.25 Costo Hall (311)
- 3.26 The Cottage (218)
- 3.27 Culver Center for the Arts (757) downtown
- 3.28 Custodial & Grounds Building (507)

E

- 3.29 Engineering Building Unit 2 (194)
- 3.30 Entomology (417)
- 3.31 Entomology Museum (256)
- 3.32 Environmental Health & Safety (241)

F

- 3.33 Fawcett Laboratory (503)

G

- 3.34 Geology Building (335)
- 3.35 Greenhouses 6–10 (200, & 275–278)
- 3.36 Greenhouses 11–14 (279–281, & 481)
- 3.37 Greenhouses 15–21
(210, 284, 483, 513–515, & 202)

H

- 3.38 Headhouse Greenhouses 1–3 (378, 259, & 374)
- 3.39 Health Services Building (495)
- 3.40 Herbarium (319)
- 3.41 Highlander Hall (716)
- 3.42 Hinderaker Hall (480)
- 3.43 Housing Administration (581)
- 3.44 Human Resources Building (788)
- 3.45 Humanities Building (498)
- 3.46 Humanities & Social Sciences Building (307)

I

- 3.47 East Campus Insectary
& Quarantine Facility (289)
- 3.48 International Village Apartments (998)

K

- 3.49 KUCR Radio Station (176)

L

- 3.50 Life Science Building (316)
- 3.51 Lothian Residence Hall (502)

O

- 3.52 Olmsted Hall (497)

P

- 3.53 Parking Services Building (272)
- 3.54 Pentland Hills Residence Hall A–Q
(365, 369, 636–648)
- 3.55 Physics Building (504)
- 3.56 Physics 2000 Lecture Hall (504A)
- 3.57 Physical Education Building (334)
- 3.58 Pierce Hall (508)
- 3.59 Police Building (566)

R

- 3.60 Rivera Library (322)

S

- 3.61 Satellite Chiller Plant (367)
- 3.62 Science Laboratories 1 (416)
- 3.63 Science Library (418)
- 3.64 Spieth Hall (323)
- 3.65 Sproul Hall (523)
- 3.66 Statistics Computer Building (588)
- 3.67 Stonehaven Apartments (991)
- 3.68 Student Recreation Center (511)

U

- 3.69 UCR/City Athletic Complex (285)
- 3.70 UCR Extension Center (722)
- 3.71 University Laboratory Building (263)
- 3.72 University Lecture Hall (383)
- 3.73 University Office Building (205)
- 3.74 University Office Building A (987)
- 3.75 University Plaza Apartments (715)

W

- 3.76 Watkins Hall (354)
- 3.77 Webber Hall (342)

Not included:

Alumni & Visitors Center (197)
 Belltower (530)
 Child Development Center B (190)
 Chancellor's Residence (488)
 CHASS Interdisciplinary
 North & South (403 & 372)
 Commons Expansion (404)
 Falkirk Apartments 1–19 (671–689)
 Genomics (196)
 Glen Mor Housing A–E (470–475)
 SASS (614)
 School of Education Clinic (397)

PLEASE NOTE:

Sign types W50 and W51 are shown both
 in the Building Identity Survey and the
 sign location plan.



CAMPUS WIDE SIGNAGE

The hundreds of signs on the UCR campus not only provide important information; they collectively form powerful and lasting impressions of the University and campus environment. Each sign should be considered a direct message from the administration and each is an opportunity to communicate clearly and present a positive image to students, faculty, staff and visitors.

Intent

Signage and graphics design guidelines seek to unify and improve all signage on the campus by:

- Organizing campus signs into useful, integrated categories
- Standardizing materials, colors and type styles
- Setting scale and size formats
- Creating appropriate relationships to landscape, architectural and lighting elements
- Selecting appropriate design details
- Organize wayfinding

Campus signage has been organized into the following functional groups:

Monument & Entry Signs

Substantial monument signs will be designed and located at key entrances to the campus. Those entrances are identified as

- [1] University Avenue & West Campus Drive
- [2] Martin Luther King Boulevard & Chicago Avenue
- [3] Canyon Crest Drive & Martin Luther King Boulevard
- [4] Big Springs Road & Valencia Hill Drive

For the main entrance signs, permanent, monumental materials such as natural stone and metal will be used to present a formal, welcoming appearance. The signs will be illuminated by remotely mounted fixtures. Letters may be fabricated of metals or incised into the surface of the monument.

In addition to the monument signs, a pylon sign of significant height and visibility will be located adjacent to the freeway. The purpose of this sign is to identify the UCR campus to freeway drivers and to provide an opportunity for University announcements of events. A high resolution LED screen will be incorporated into the pylon, providing a methodology by which the University can communicate directly with the community.

Vehicular Directional Signs and Parking Identification

A system of vehicular signage will be designed and deployed throughout the campus roadways and parking areas. The vehicular sign system will be comprised of directional signs, parking identification signs and street name signs. These signs will display important and “reachable-by-car” campus destinations, and adjacent parking areas, with directional arrows. The signs

will be highly visible and recognizable from over 150 ft. where sight lines allow. *(Drivers should always be able to see at least one directional sign from anywhere on the campus roadways, thus providing substantial driver reassurance.)* The type style should be Trade Gothic Bold No.2 for clarity and easy reading by drivers with reflective qualities for night reading.

Pedestrian Directional Signs

A system of pedestrian-directional signage will be designed and deployed throughout the campus. The directional signs should display important and frequented campus destinations with directional arrows. The directional signs will be a “finger-sign” or pointer style design that features pointed slats for each destination. Signs of this style are very pedestrian friendly and are less prone to vandalism. The height of these signs will be eight to ten feet. The type style should be a simple, bold sans-serif font for clarity and easy reading. Wording on the signs should be simple and use the shortest messages possible. The formal names of some destinations may need to be shortened for effective display on signs.

Pedestrian Map Directories

A system of map directories with lighting for night reading will be designed and deployed throughout the campus presenting an illustrated campus map and detailed listing of all destinations. The directories will present a clear, colorful map, matching that of printed hand-out maps. Maps will be easily changeable to allow for regularly updating campus information.

Information Kiosks

Interactive kiosks will be installed for the display of campus information. Information links within the kiosk software can help foster communication, student interest and help build community on the campus.

Freestanding Building Signage

A system of free-standing building identification signage will be designed and deployed throughout the campus. Each sign will display the formal name of a campus building and be located near the main building entry door. The signs should be highly visible and recognizable from over 200 feet where sight lines allow. These signs will reflect the University’s blue and gold coloration, but will feature a more architecturally sensitive neutral background color. A letter size of approximately two to three inches will be used. The type style should be Trade Gothic Bold No.2 for clarity and easy reading.

Building-Mounted Signage

Building-mounted signs will be comprised of three categories; architectural letter signs, panel signs and door mounted signs. These signs are to be used in a variety of configurations in order to provide adequate visibility and identification for the building. Architectural letter signs are to be used to prominently identify buildings, generally at or near the top of the structure. Letter size and location should be appropriately scaled and proportioned to the overall

building. Panel signs usually at eye level or slightly above, should be used to supplement the architectural letter signs where building identification is required closer to the entry path. Door mounted signs shall be applied to all main building entry doors. These signs shall be applied vinyl letters applied subsurface to clear glass.

Design Considerations

A wide variety of design approaches and opportunities exist for the signage at UCR. However, while the designs can be simple and understated, or play a more dramatic role, a contemporary, clean-line approach should be used. The buildings of the University are an eclectic mix of architectural and design styles. Signage will be designed to compliment and help unify the campus’s diversity of styles.

Interior Signage

A system of interior signs has been developed to give consistency to the location, size, materials and color of the graphic elements within buildings. Directional signage, room number identification, building and floor directories, and all code required signs shall be laid out and located in accordance with the UCR Interior Signage Guidelines

Color and Contrast

With its large scale, open spaces and long sight lines, the campus needs highly visible and recognizable signs. The use of bold and high contrast colors and materials will help signage elements stand out in the environment. Directional signage will reflect the University’s school colors of blue and gold with sign messages in white. Monument signage will be constructed using a more architectural palette of natural stone and metal finishes.

For more details, please consult the Campus Sign Program, posted on the UCR Capital and Physical Planning website. (www.ucrapb.ucr.edu)

PROJECT TYPESTYLES:

ABCDEFGHIJKLMNOPQRSTUVWXYZ 1234567890

abcdefghijklmnopqrstuvwxyz

Times Bold

ABCDEFGHIJKLMNOPQRSTUVWXYZ 1234567890

abcdefghijklmnopqrstuvwxyz

Times Regular

ABCDEFGHIJKLMNOPQRSTUVWXYZ 1234567890

abcdefghijklmnopqrstuvwxyz

Trade Gothic Bold

ABCDEFGHIJKLMNOPQRSTUVWXYZ 1234567890

abcdefghijklmnopqrstuvwxyz

Trade Gothic Bold No. 2

ABCDEFGHIJKLMNOPQRSTUVWXYZ 1234567890

abcdefghijklmnopqrstuvwxyz

Din Medium



Project Symbols and Arrow

Note:
Times (Bold/Regular) is not to be used on any sign required to be ADA compliant. Use only sans serif font on any sign complying with accessibility code.

GUIDELINES FOR TEXT KERNING:

Letter Spacing

Spacing "0 pt." Minimum

Letter Spacing

Spacing "20 pt." Maximum (Recommended Standard)

Line Spacing

Spacing Between Lines In Paragraph Format 116.67 % Of Letter Height.

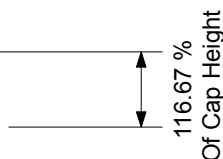

COLOR SCHEDULE: EXTERIOR SIGNAGE

No.	Color No.	Color Name	Finish
1	MP10273	Blue	Semi gloss
2	MP04516	Gold	Semi gloss
3	Davis Concrete Color	Mesa Buff 2lbs. 5447	
4	3M Scotchlite EGR 3290	White Reflective Vinyl	
5	MP-White	White	Semi gloss
6	3M Scotchcal 7125-10	White	
7	MP18100	Light Silver	Semi gloss
8	MP20140	Gray	Semi gloss
9	MP07694	Light Blue	Semi gloss
10	3M Scotchcal 7125-13	Red	
11	3M Scotchlite EGR 3275	Blue Reflective Vinyl	
12	MP04705	Terra Cotta	Semi gloss
13	3M Scotchlite EGR 3271	Yellow	
14	3M Scotchlite EGR 3272	Red	
15	3M Scotchcal 7125-12	Black	

COLOR SCHEDULE: BUILDING INTERIOR SIGNAGE

No.	Color No.	Color Name	Finish
1	MP13915	Gray	Satin Finish
2	MP 06668	Light Gray	Satin Finish
3	3M Scotchcal Vinyl	7125-10 White	
4	3M Scotchcal Vinyl	7125-13 Red	
5	MP White	White	Satin Finish
6	Gravoply II 21927	Gray/white	
7	Aluminum		Light Sandblast Finish

MP = Matthews Paint

EGR = 3M Engineering Grade Reflective Vinyl

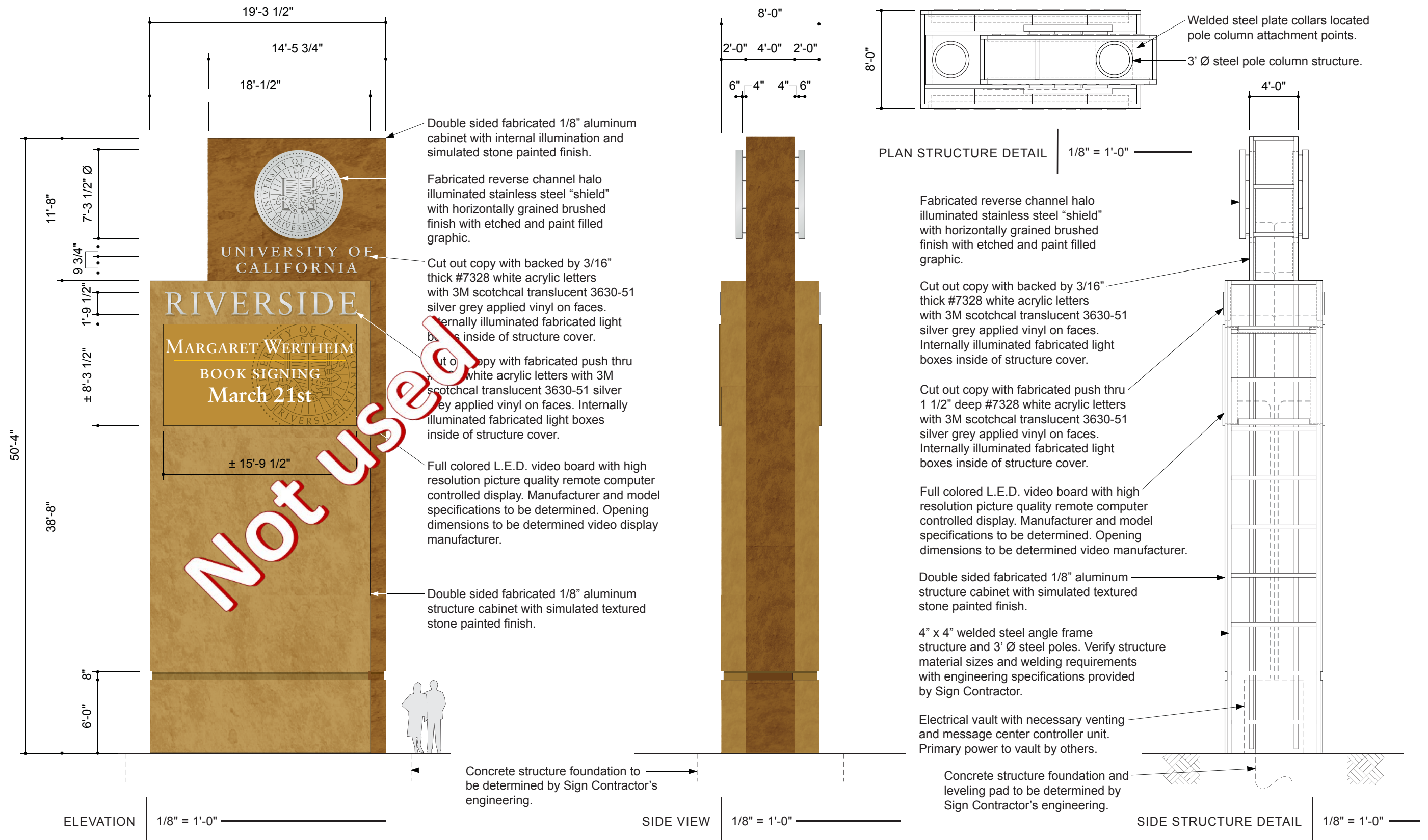

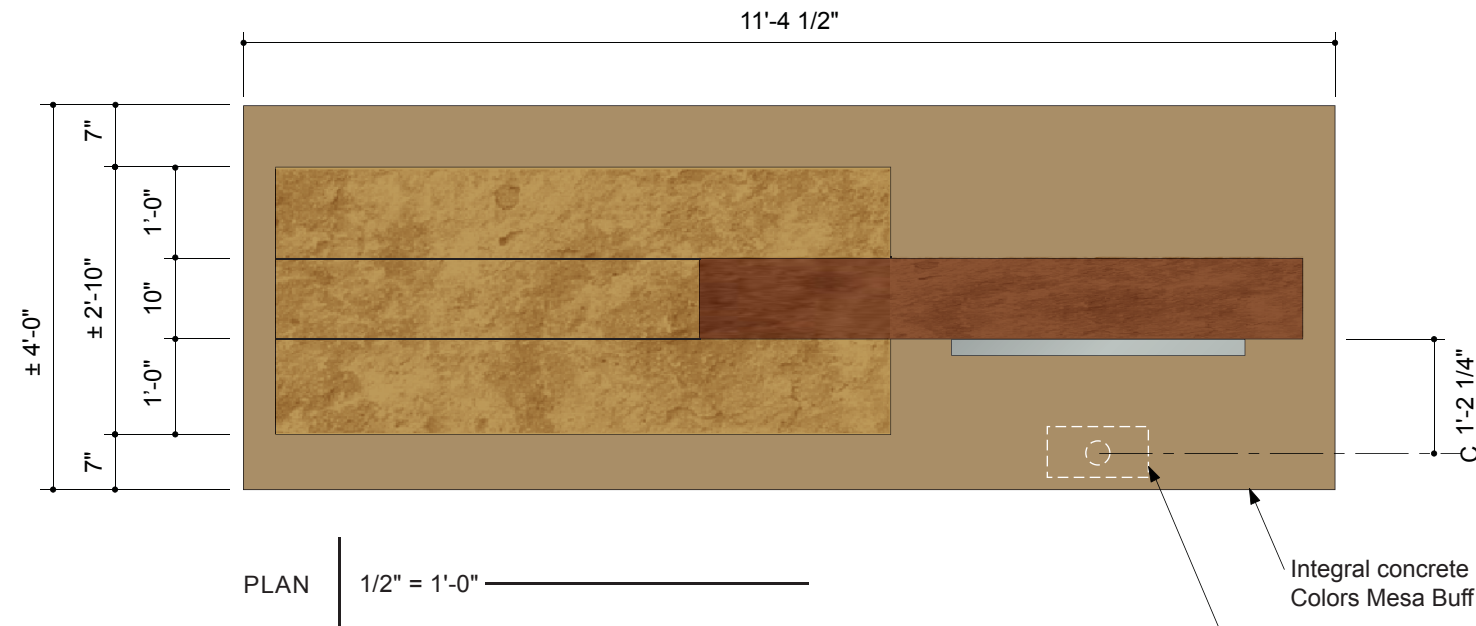

W11 SINGLE SIDE SIGN ORIENTATION: Not To Scale

- Single Faced - (Location sheet 2.6) Linden St. @ Canyon Crest Dr.
- Single Faced - (Location sheet 2.12) Valencia Hills Dr. @ Big Springs Rd.
- Single Faced - (Location sheet 2.14) Campus Dr. @ Canyon Crest Dr.



Flat cut out horizontally brushed stainless steel letters with 1/4" stainless steel spacer sleeves and blind studs.

Fabricated 2" thick stainless steel "shield" with light horizontal brushed finish. Graphics to be etched 1/32" deep and paint filled.

1" deep Incised letters with painted finish inside of letters. Paint color Matthews MP10217 Brown.

Full colored L.E.D. video board with high resolution picture quality remote computer controlled display. Manufacturer and model specifications to be determined. Opening dimensions to be determined video display manufacturer.

Fabricated aluminum frame structure with stone facing. Dark red / brown facing to be morning glory stone with oil rubbed finish. Light ochre / brown facing to be sunflower stone with oil rubbed finish.

Arida fluorescent outdoor architectural lighting. Sign Contractor to minimize fixture above grade as possible. (or equivalent lighting product)

Concrete footing / integral colored mow pad to be determined by Sign Contractor's engineering.

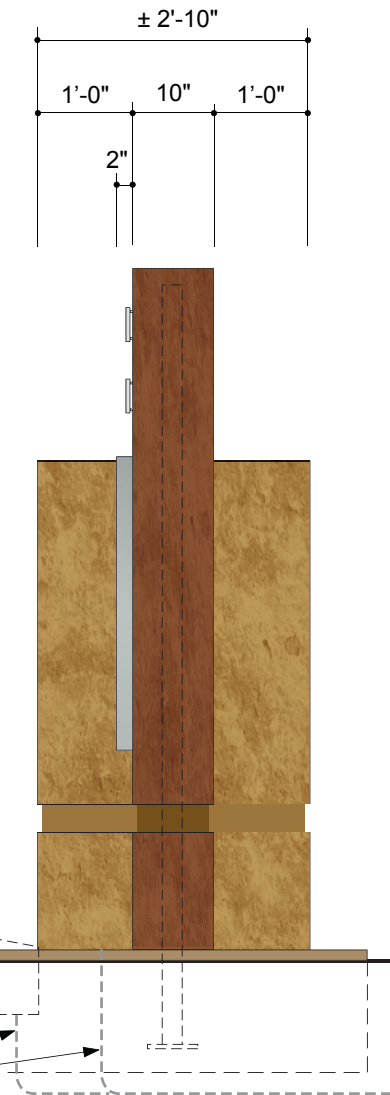

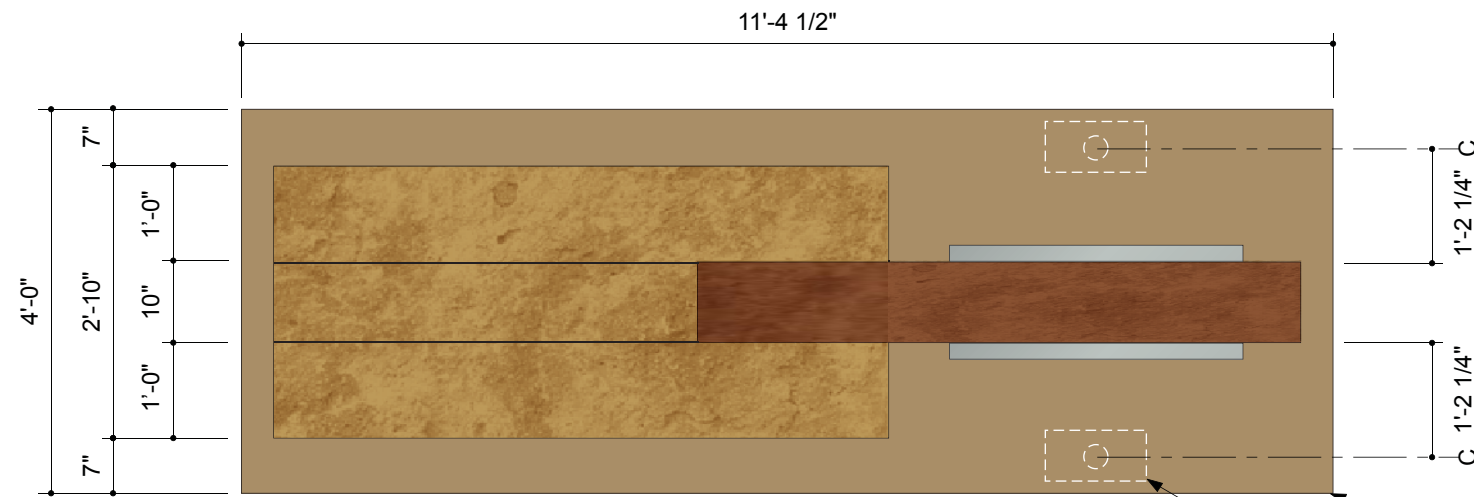

PLAN 1/2" = 1'-0"



W11 DOUBLE SIDED SIGN ORIENTATION: Not To Scale
 Double Faced - (Location sheet 2.6) Linden St. @ Flower St.
 Double Faced - (Location sheet 2.10) University Dr. @ W. Campus Dr.



ELEVATION 1/2" = 1'-0"

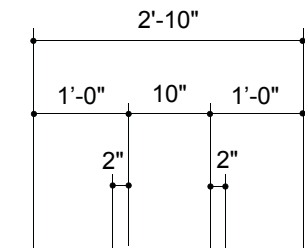

SIDE 1/2" = 1'-0"

NOT USED

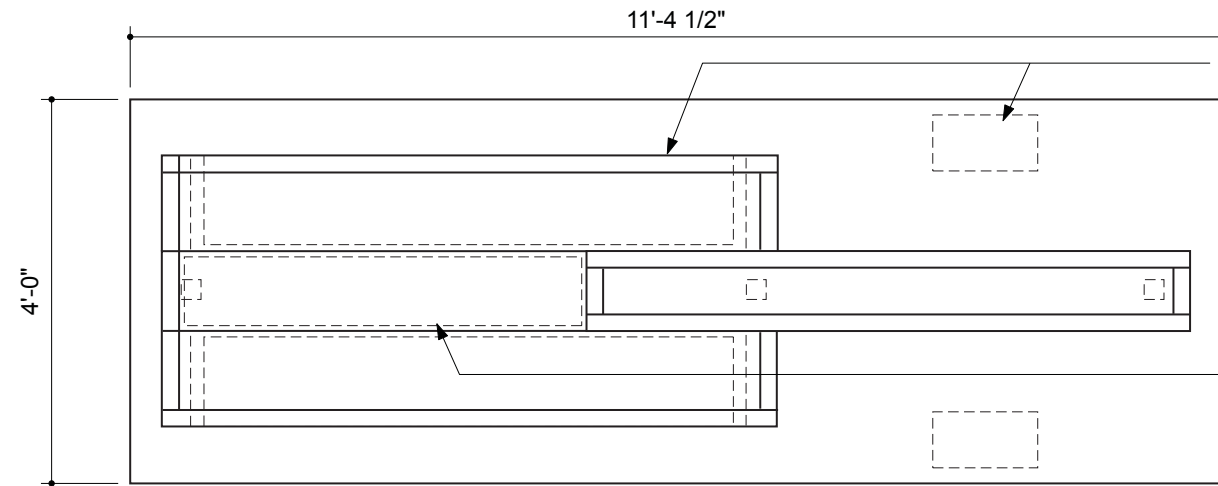

PLAN 1/2" = 1'-0"

For single faced displays cover message display opening with stone panel and eliminate exterior lighting on back side only.

Flush aluminum service access for message display controller. Venting for excess heat to be determined by message display manufacturer. Use tamperproof fastening or locking device for panel access.

General Notes:

1. Sign construction details conceptual only, sign contractor's engineering to take precedence over any drawing details.
2. Stone and or color matches can be purchased through Contractor's Tile Mart, 1063 E. Las Tunas Dr., San Gabriel, Calif. 91776 - Tel. (626) 287-6483 - Attn. Albert Maloof

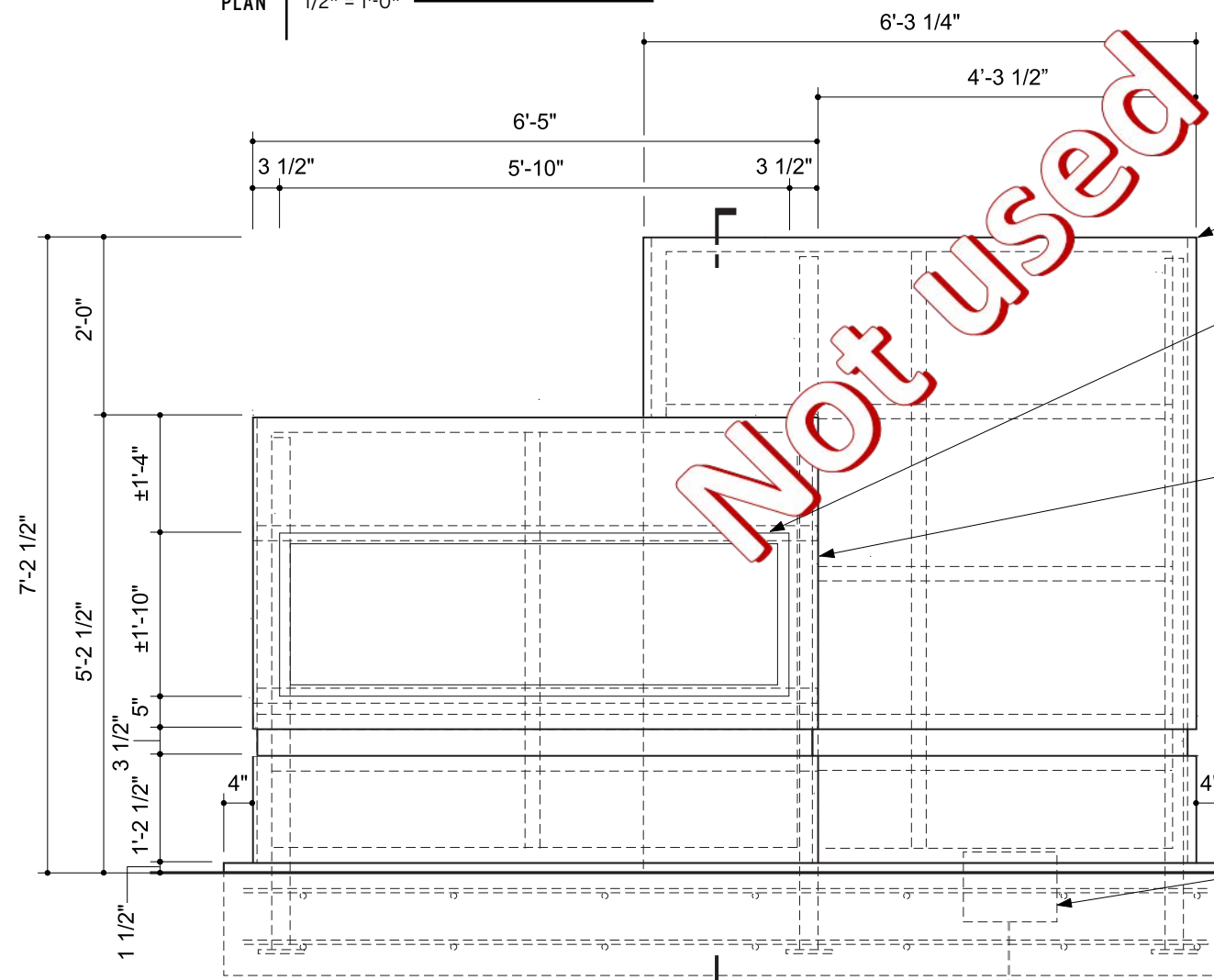

ELEVATION 1/2" = 1'-0"

Not Used

Flat cut out horizontally brushed stainless steel letters with 1/4" stainless steel spacer sleeves and blind studs.

Fabricated aluminum frame structure with stone facing. stone facing. Light ochre / brown facing to be sunflower stone with oil rubbed finish.

Full colored L.E.D. video board with high resolution picture quality remote computer controlled display. Manufacturer and model specifications to be determined. Opening dimensions to be determined video display manufacturer.

Fabricated aluminum frame structure with stone facing. Dark red / brown facing to be morning glory stone with oil rubbed finish.

Threaded stainless steel studs / anchor pins with masonry holes filled with epoxy sealant.

3" square steel tubes with 3/8" thick bottom plate. Verify with Sign Contractor's engineering.

Perforated aluminum around display for venting painted black.

Stainless steel "Z" clips / brackets with fasteners to support stone.

2" x 2" x 1/4" steel angle welded frame structure to support stone and electronic message display.

Arida fluorescent outdoor architectural lighting. Sign Contractor to minimize fixture above grade as possible. (or equivalent lighting product)

Concrete footing / integral colored mow pad to be determined by Sign Contractor's engineering.

Primary power to sign location by UCR.

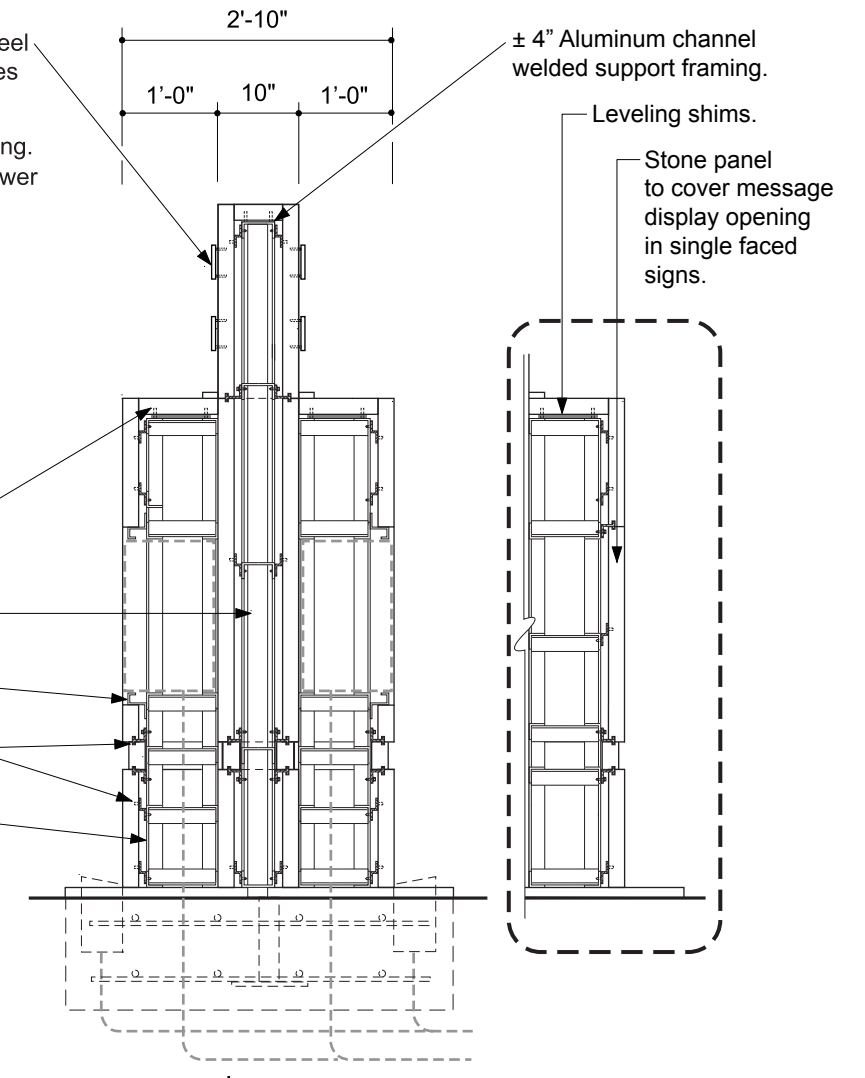

DOUBLE SIDED SECTION 1/2" = 1'-0" A

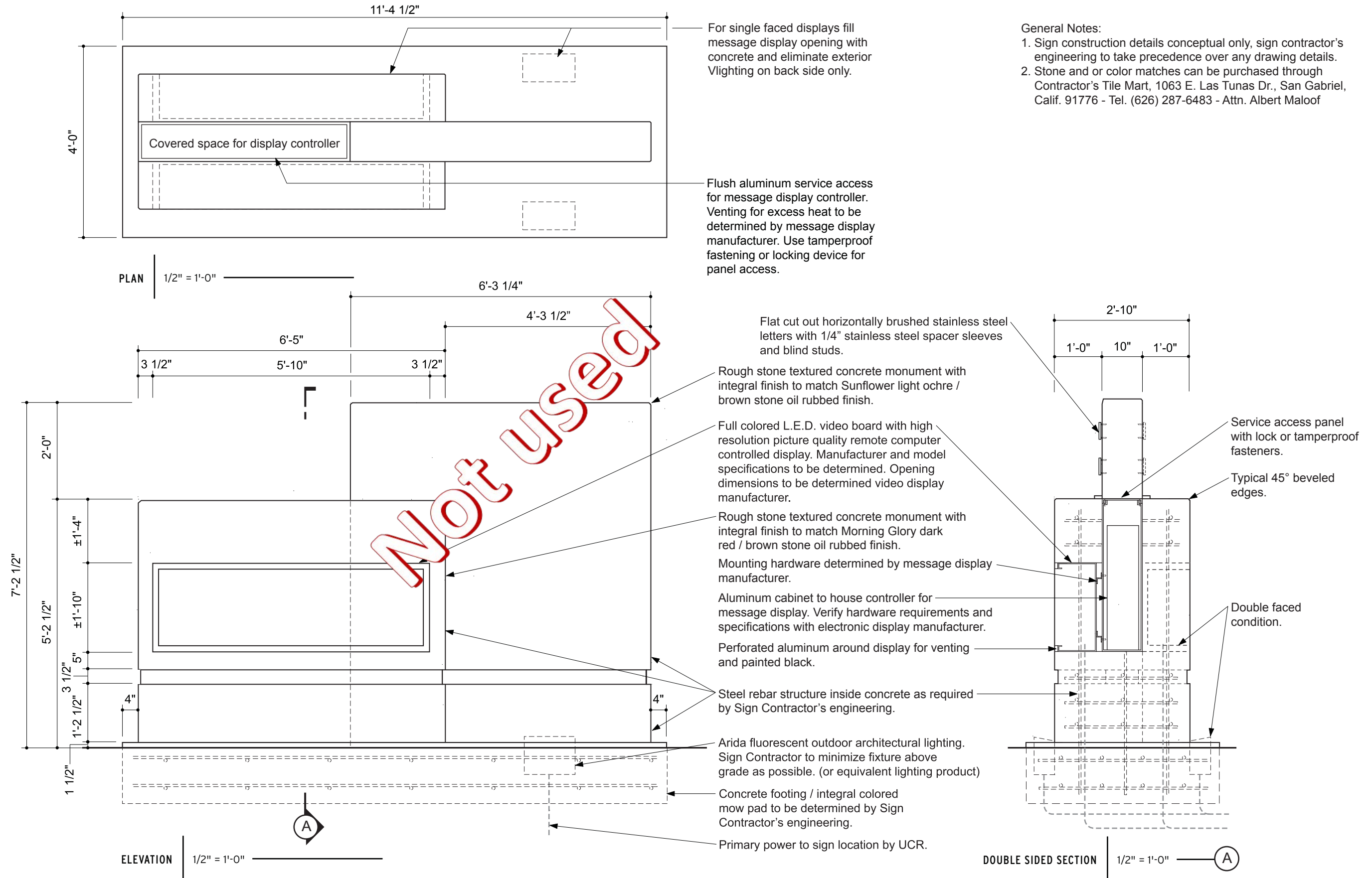

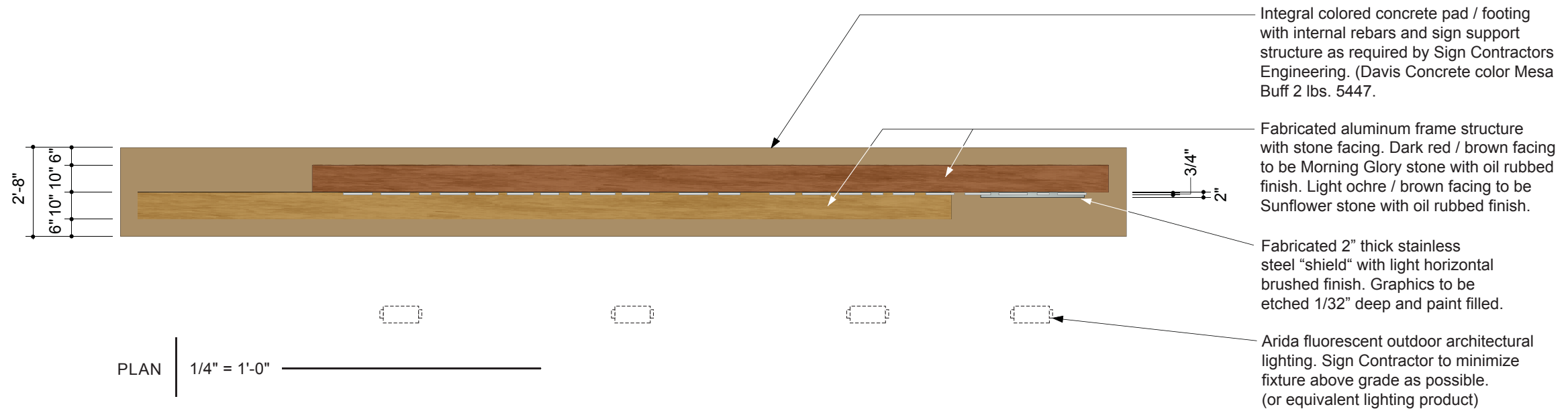

Not used

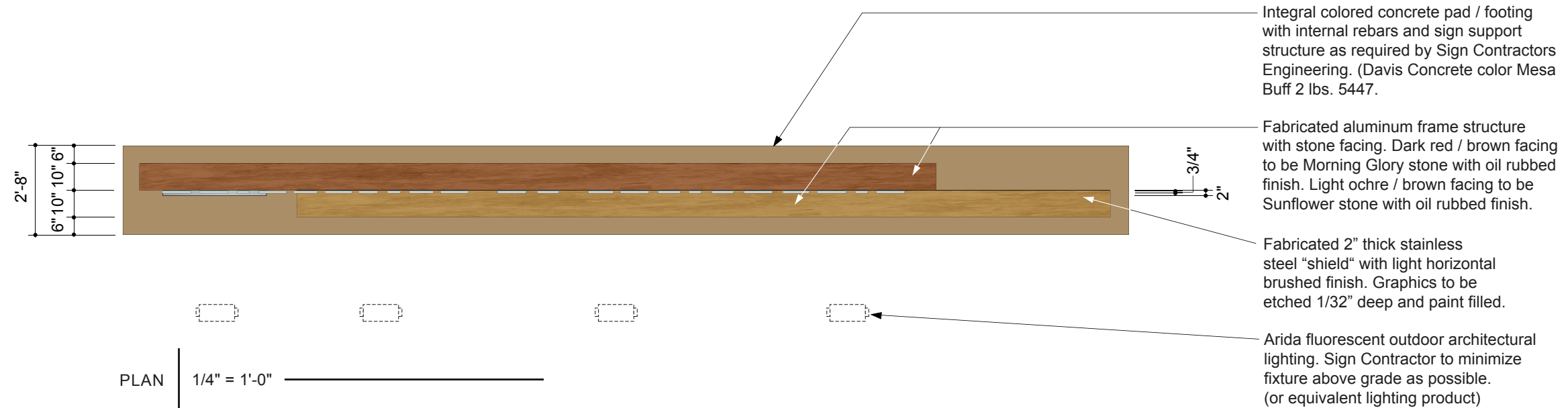

- 3/4" thick flat cut out horizontally brushed stainless steel letters with 1/4" stainless steel spacer sleeves and blind studs.
- 1" deep Incised letters with painted Matthews MP10217 Brown.
- Exterior lighting.
- Primary power to location by UCR.
- Concrete footing / integral colored mow pad to be determined by Sign Contractor's engineering.

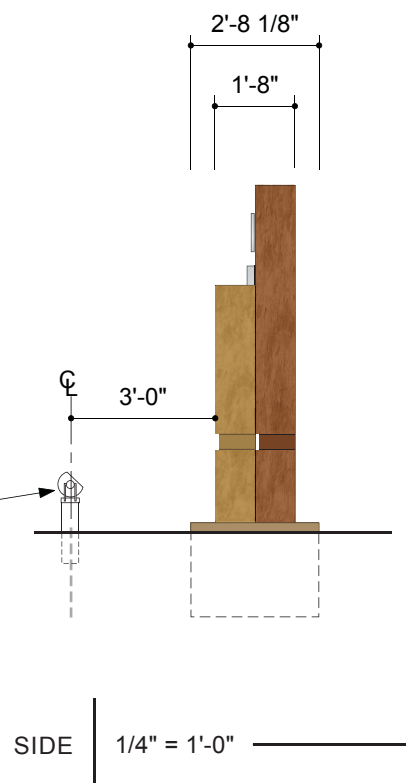

Not used



East side of Canyon Crest Dr. - (1) single faced sign

ELEVATION 3/16" = 1'-0" W16 Single Faced - (Location sheet 2.18) MLK Jr. Blvd. @ Canyon Crest Dr.

Fabricated 2" thick stainless steel "shield" with light horizontal brushed finish. Graphics to be etched 1/32" deep and paint filled.

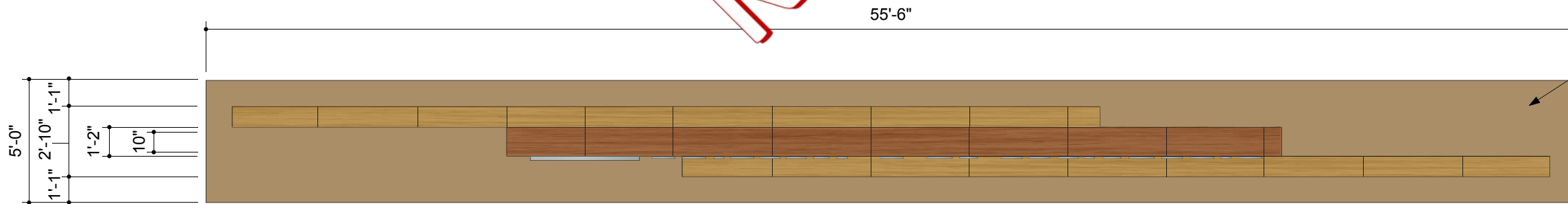

PLAN 3/16" = 1'-0"

Fabricated aluminum frame structure with stone facing. Dark red / brown facing to be Morning Glory stone with oil rubbed finish. Light ochre / brown facing to be Sunflower stone with oil rubbed finish.

Integral colored concrete pad / footing with internal rebar and sign support structure as required by Sign Contractors Engineering. (Davis Concrete color Mesa Buff 2 lbs. 5447.

Arida fluorescent outdoor architectural lighting. Sign Contractor to minimize fixture above grade as possible. (or equivalent lighting product)

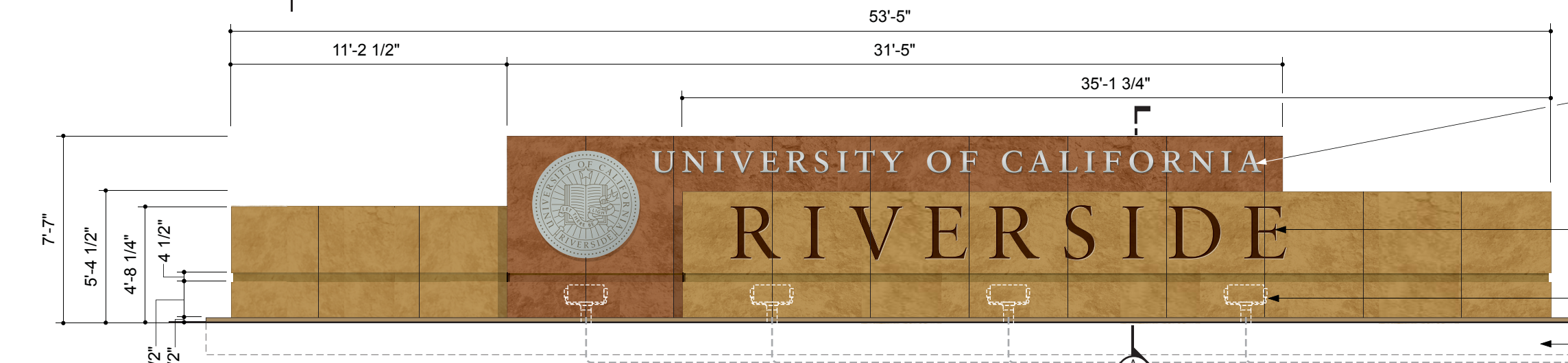

West side of Canyon Crest Dr. - (1) single faced sign

ELEVATION 3/16" = 1'-0" W16 Single Faced - (Location sheet 2.18) MLK Jr. Blvd. @ Canyon Crest Dr.

3/4" thick flat cut out horizontally brushed stainless steel letters with 1/4" stainless steel spacer sleeves and blind studs.

1" deep Incised letters with painted Matthews MP10217 Brown.

Exterior lighting.

Concrete footing / integral colored mow pad to be determined by Sign Contractor's engineering.

Primary power to sign location by UC Riverside.

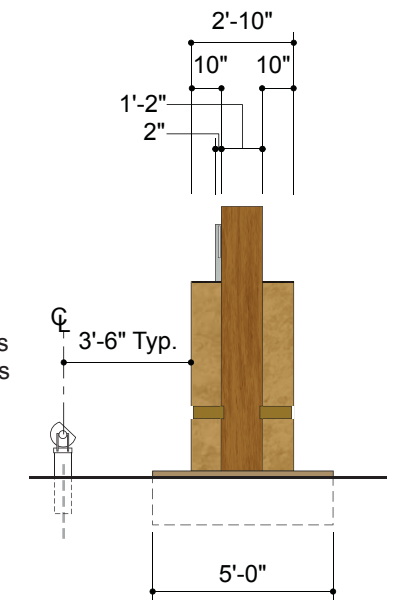

SIDE 3/16" = 1'-0"

Not Used

Not Used

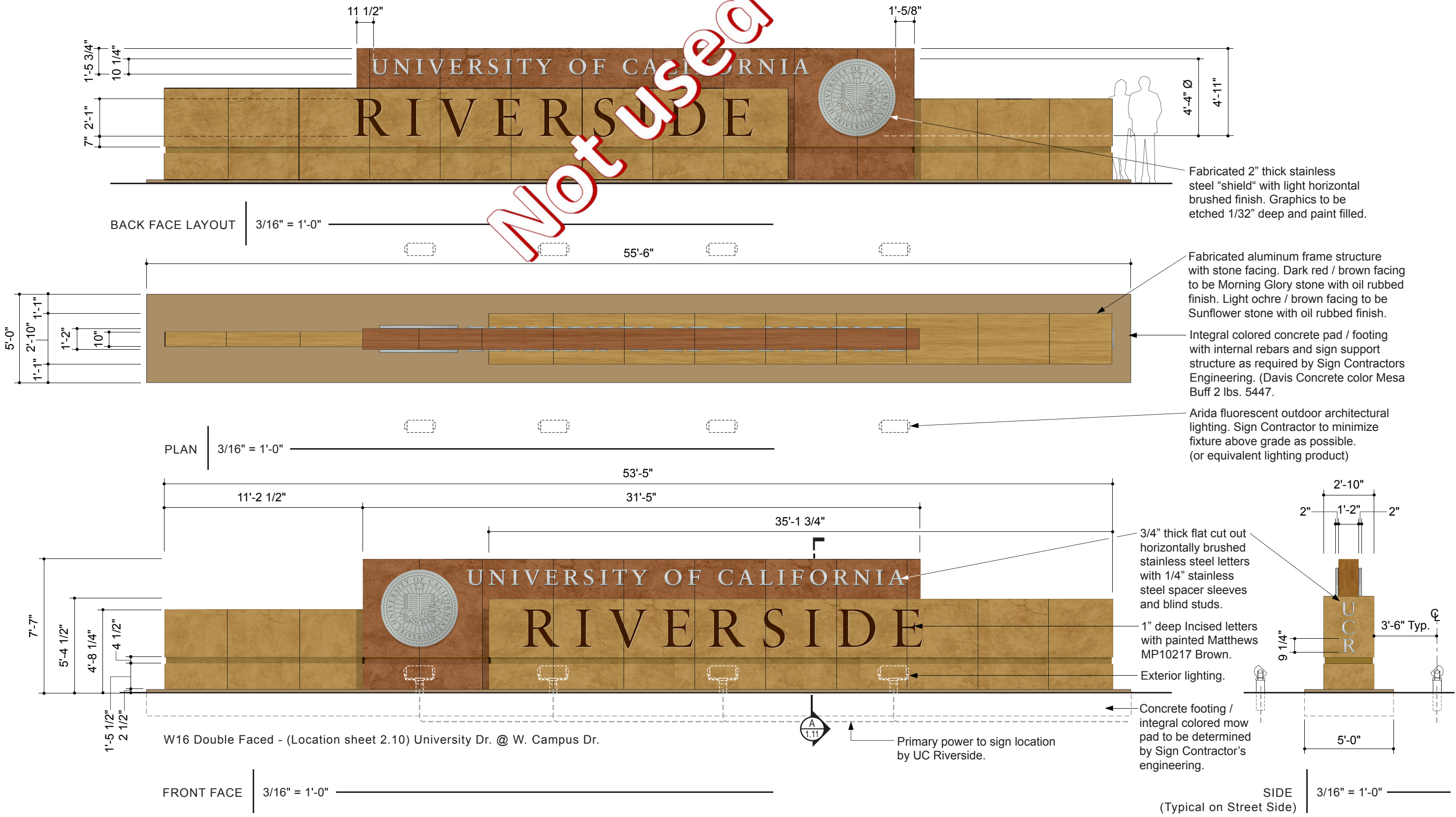

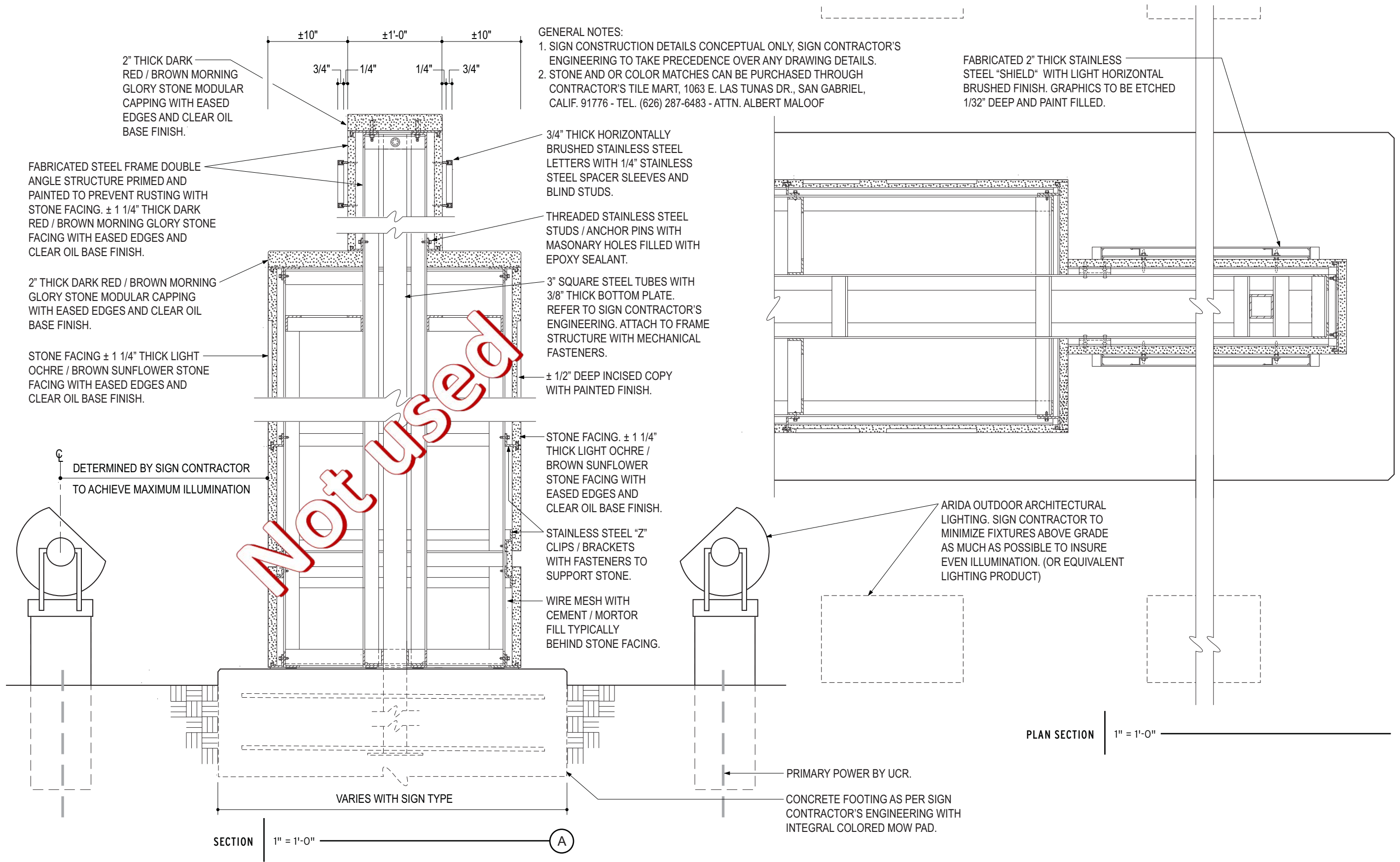

GENERAL NOTES:
 1. SIGN CONSTRUCTION DETAILS CONCEPTUAL ONLY, SIGN CONTRACTOR'S ENGINEERING TO TAKE PRECEDENCE OVER ANY DRAWING DETAILS.
 2. STONE AND OR COLOR MATCHES CAN BE PURCHASED THROUGH CONTRACTOR'S TILE MART, 1063 E. LAS TUNAS DR., SAN GABRIEL, CALIF. 91776 - TEL. (626) 287-6483 - ATTN. ALBERT MALOOF

FABRICATED 2" THICK STAINLESS STEEL "SHIELD" WITH LIGHT HORIZONTAL BRUSHED FINISH. GRAPHICS TO BE ETCHED 1/32" DEEP AND PAINT FILLED.

2" THICK DARK RED / BROWN MORNING GLORY STONE MODULAR CAPPING WITH EASED EDGES AND CLEAR OIL BASE FINISH.

FABRICATED STEEL FRAME DOUBLE ANGLE STRUCTURE PRIMED AND PAINTED TO PREVENT RUSTING WITH STONE FACING. ± 1 1/4" THICK DARK RED / BROWN MORNING GLORY STONE FACING WITH EASED EDGES AND CLEAR OIL BASE FINISH.

2" THICK DARK RED / BROWN MORNING GLORY STONE MODULAR CAPPING WITH EASED EDGES AND CLEAR OIL BASE FINISH.

STONE FACING ± 1 1/4" THICK LIGHT OCHRE / BROWN SUNFLOWER STONE FACING WITH EASED EDGES AND CLEAR OIL BASE FINISH.

3/4" THICK HORIZONTALLY BRUSHED STAINLESS STEEL LETTERS WITH 1/4" STAINLESS STEEL SPACER SLEEVES AND BLIND STUDS.

THREADED STAINLESS STEEL STUDS / ANCHOR PINS WITH MASONARY HOLES FILLED WITH EPOXY SEALANT.

3" SQUARE STEEL TUBES WITH 3/8" THICK BOTTOM PLATE. REFER TO SIGN CONTRACTOR'S ENGINEERING. ATTACH TO FRAME STRUCTURE WITH MECHANICAL FASTENERS.

± 1/2" DEEP INCISED COPY WITH PAINTED FINISH.

STONE FACING ± 1 1/4" THICK LIGHT OCHRE / BROWN SUNFLOWER STONE FACING WITH EASED EDGES AND CLEAR OIL BASE FINISH.

STAINLESS STEEL "Z" CLIPS / BRACKETS WITH FASTENERS TO SUPPORT STONE.

WIRE MESH WITH CEMENT / MORTOR FILL TYPICALLY BEHIND STONE FACING.

ARIDA OUTDOOR ARCHITECTURAL LIGHTING. SIGN CONTRACTOR TO MINIMIZE FIXTURES ABOVE GRADE AS MUCH AS POSSIBLE TO INSURE EVEN ILLUMINATION. (OR EQUIVALENT LIGHTING PRODUCT)

DETERMINED BY SIGN CONTRACTOR TO ACHIEVE MAXIMUM ILLUMINATION

PRIMARY POWER BY UCR.

CONCRETE FOOTING AS PER SIGN CONTRACTOR'S ENGINEERING WITH INTEGRAL COLORED MOW PAD.

SECTION 1" = 1'-0" A

PLAN SECTION 1" = 1'-0"

Not Used

VARIES WITH SIGN TYPE

GENERAL NOTES:

1. SIGN CONSTRUCTION DETAILS CONCEPTUAL ONLY, SIGN CONTRACTOR'S ENGINEERING TO TAKE PRECEDENCE OVER ANY DRAWING DETAILS.
2. STONE AND OR COLOR MATCHES CAN BE PURCHASED THROUGH CONTRACTOR'S TILE MART, 1063 E. LAS TUNAS DR., SAN GABRIEL, CALIF. 91776 - TEL. (626) 287-6483 - ATTN. ALBERT MALOOF

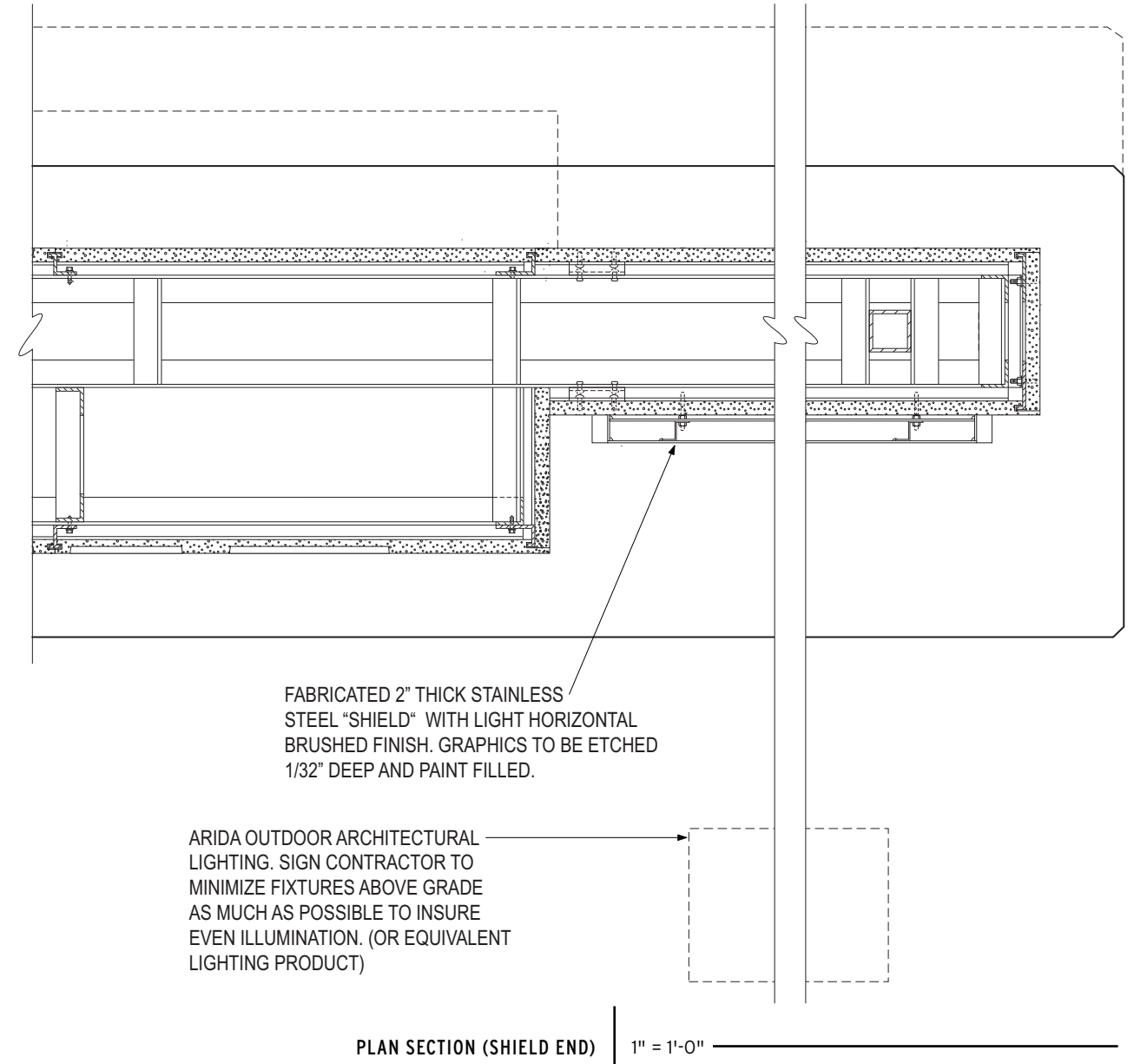
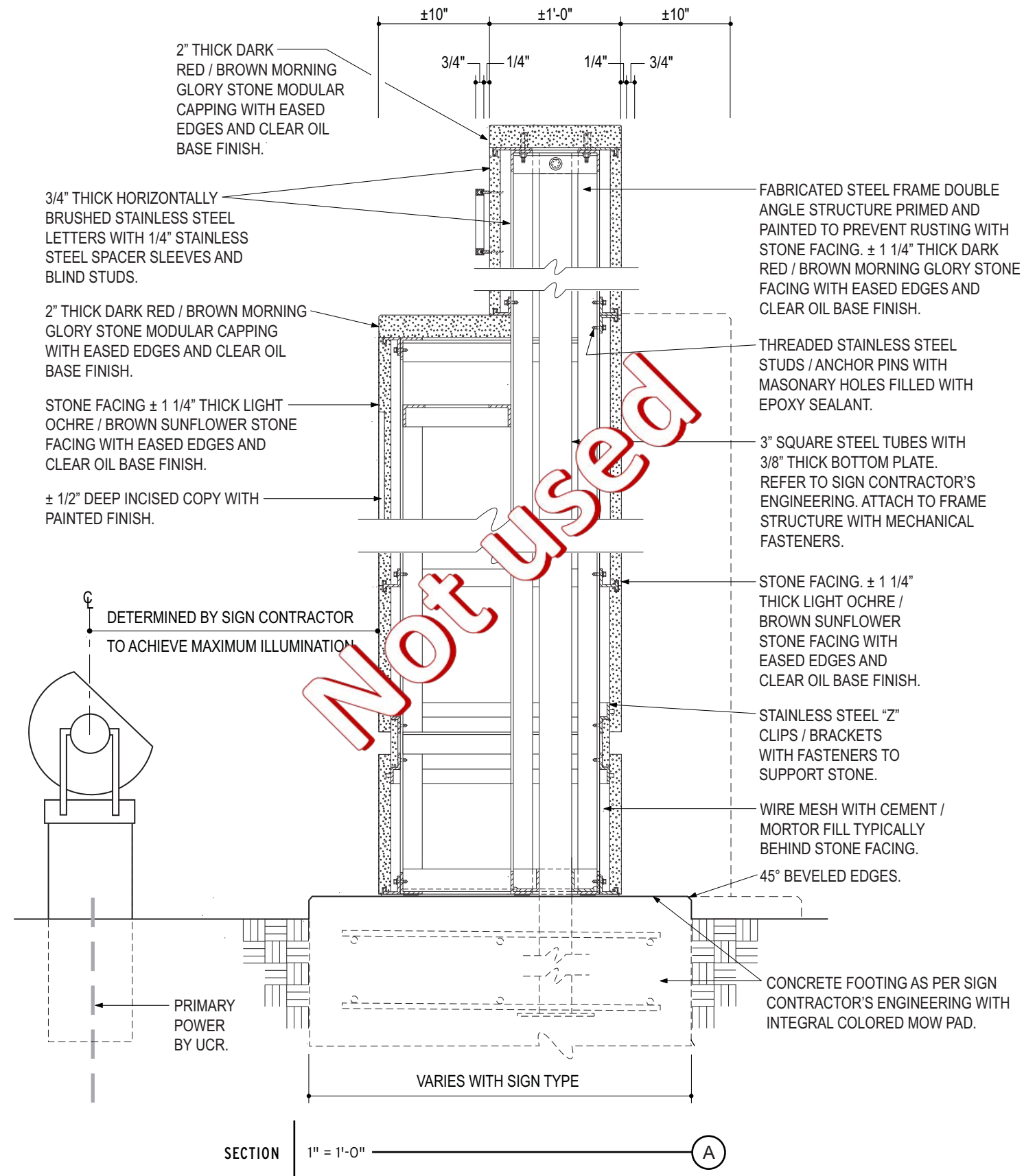

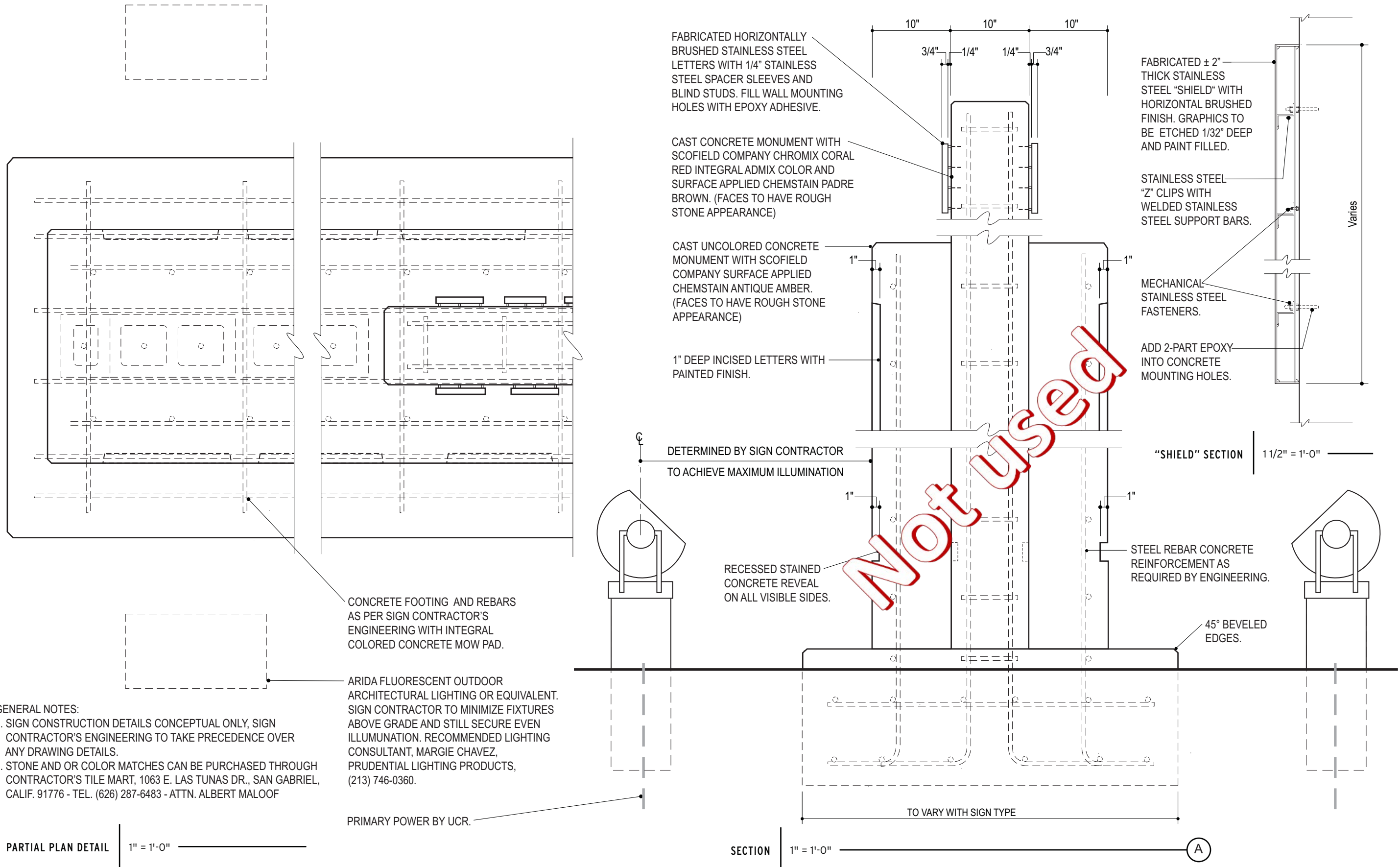

GENERAL NOTES:

1. SIGN CONSTRUCTION DETAILS CONCEPTUAL ONLY, SIGN CONTRACTOR'S ENGINEERING TO TAKE PRECEDENCE OVER ANY DRAWING DETAILS.
2. STONE AND OR COLOR MATCHES CAN BE PURCHASED THROUGH CONTRACTOR'S TILE MART, 1063 E. LAS TUNAS DR., SAN GABRIEL, CALIF. 91776 - TEL. (626) 287-6483 - ATTN. ALBERT MALOOF

PARTIAL PLAN DETAIL

1" = 1'-0"

SECTION

1" = 1'-0"

A

GENERAL NOTES:

1. SIGN CONSTRUCTION DETAILS CONCEPTUAL ONLY, SIGN CONTRACTOR'S ENGINEERING TO TAKE PRECEDENCE OVER ANY DRAWING DETAILS.
2. STONE AND OR COLOR MATCHES CAN BE PURCHASED THROUGH CONTRACTOR'S TILE MART, 1063 E. LAS TUNAS DR., SAN GABRIEL, CALIF. 91776 - TEL. (626) 287-6483 - ATTN. ALBERT MALOOF

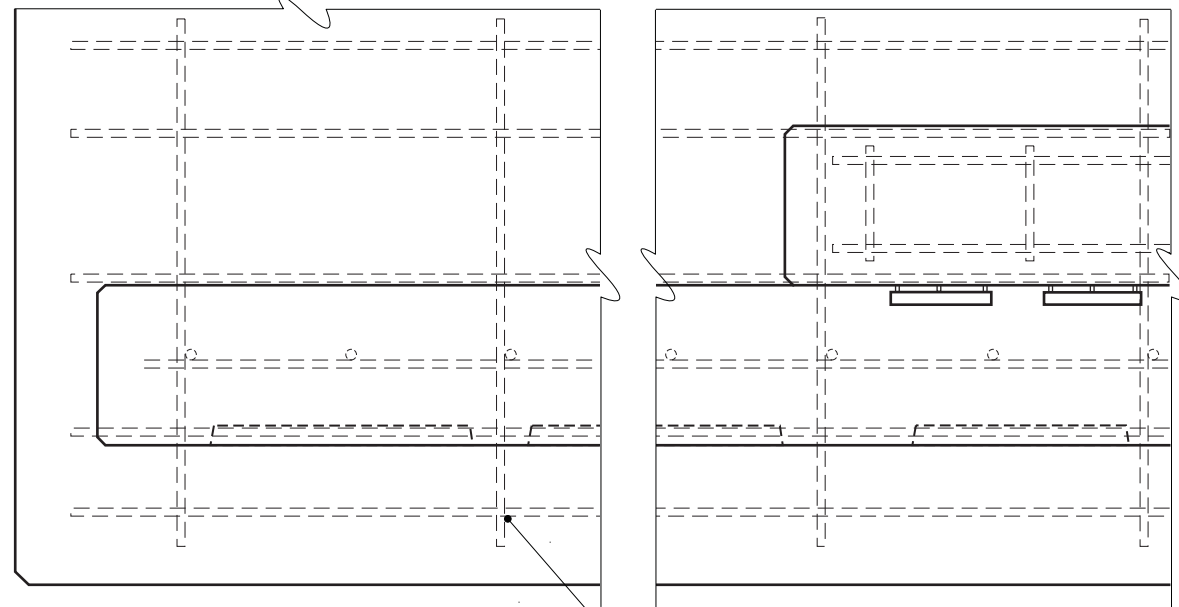

PARTIAL PLAN DETAIL

1" = 1'-0"

CONCRETE FOOTING AND REBARS AS PER SIGN CONTRACTOR'S ENGINEERING WITH INTEGRAL COLORED CONCRETE MOW PAD.

ARIDA FLUORESCENT OUTDOOR ARCHITECTURAL LIGHTING OR EQUIVALENT. SIGN CONTRACTOR TO MINIMIZE FIXTURES ABOVE GRADE AND STILL SECURE EVEN ILLUMINATION. RECOMMENDED LIGHTING CONSULTANT, MARGIE CHAVEZ, PRUDENTIAL LIGHTING PRODUCTS, (213) 746-0360.

PRIMARY POWER BY UCR.

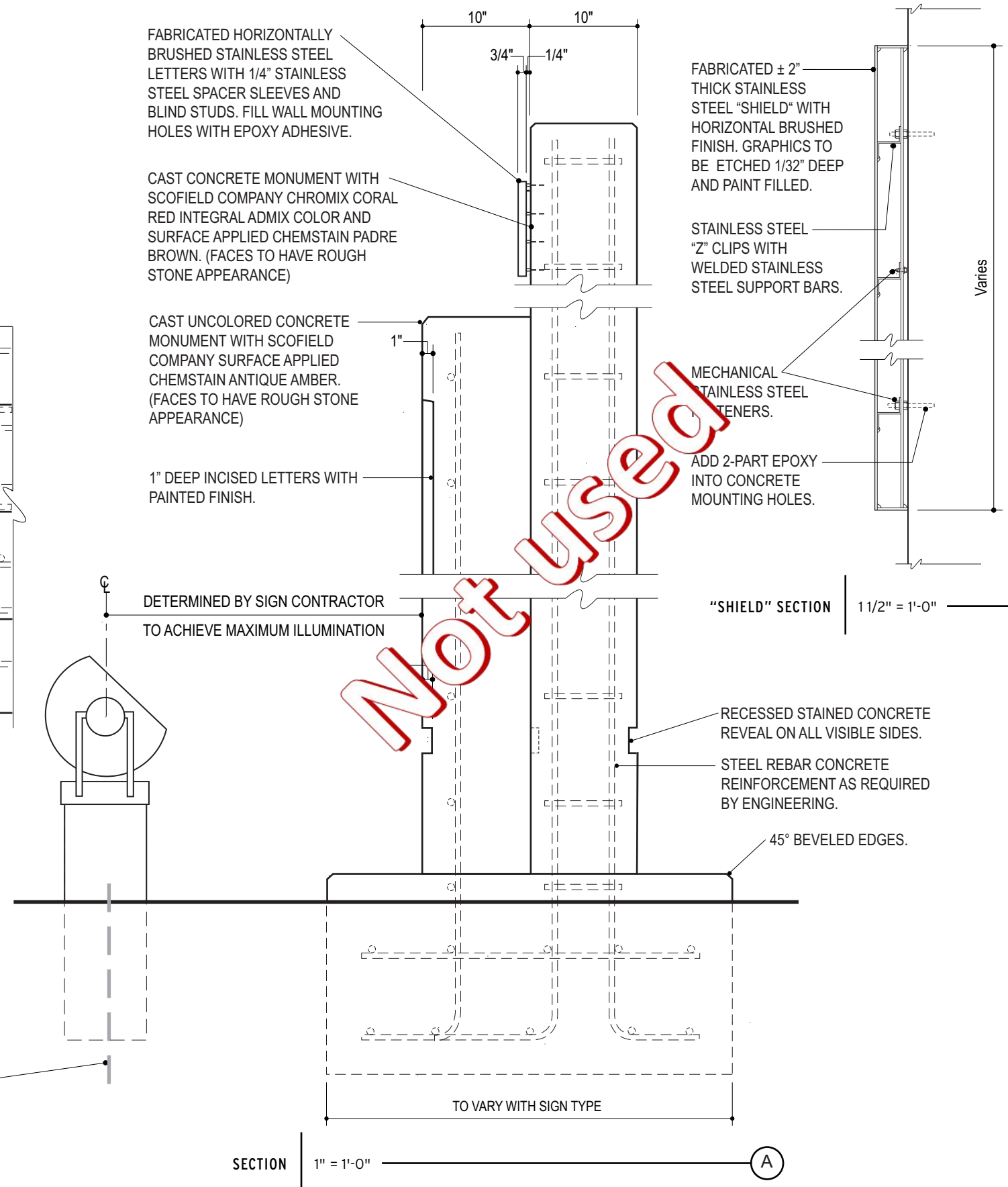

FABRICATED HORIZONTALLY BRUSHED STAINLESS STEEL LETTERS WITH 1/4" STAINLESS STEEL SPACER SLEEVES AND BLIND STUDS. FILL WALL MOUNTING HOLES WITH EPOXY ADHESIVE.

CAST CONCRETE MONUMENT WITH SCOFIELD COMPANY CHROMIX CORAL RED INTEGRAL ADMIX COLOR AND SURFACE APPLIED CHEMSTAIN PADRE BROWN. (FACES TO HAVE ROUGH STONE APPEARANCE)

CAST UNCOLORED CONCRETE MONUMENT WITH SCOFIELD COMPANY SURFACE APPLIED CHEMSTAIN ANTIQUE AMBER. (FACES TO HAVE ROUGH STONE APPEARANCE)

1" DEEP INCISED LETTERS WITH PAINTED FINISH.

DETERMINED BY SIGN CONTRACTOR TO ACHIEVE MAXIMUM ILLUMINATION

FABRICATED ± 2" THICK STAINLESS STEEL "SHIELD" WITH HORIZONTAL BRUSHED FINISH. GRAPHICS TO BE ETCHED 1/32" DEEP AND PAINT FILLED.

STAINLESS STEEL "Z" CLIPS WITH WELDED STAINLESS STEEL SUPPORT BARS.

MECHANICAL STAINLESS STEEL TENSERS.

ADD 2-PART EPOXY INTO CONCRETE MOUNTING HOLES.

"SHIELD" SECTION 1 1/2" = 1'-0"

RECESSED STAINED CONCRETE REVEAL ON ALL VISIBLE SIDES.

STEEL REBAR CONCRETE REINFORCEMENT AS REQUIRED BY ENGINEERING.

45° BEVELED EDGES.

TO VARY WITH SIGN TYPE

SECTION 1" = 1'-0"

A

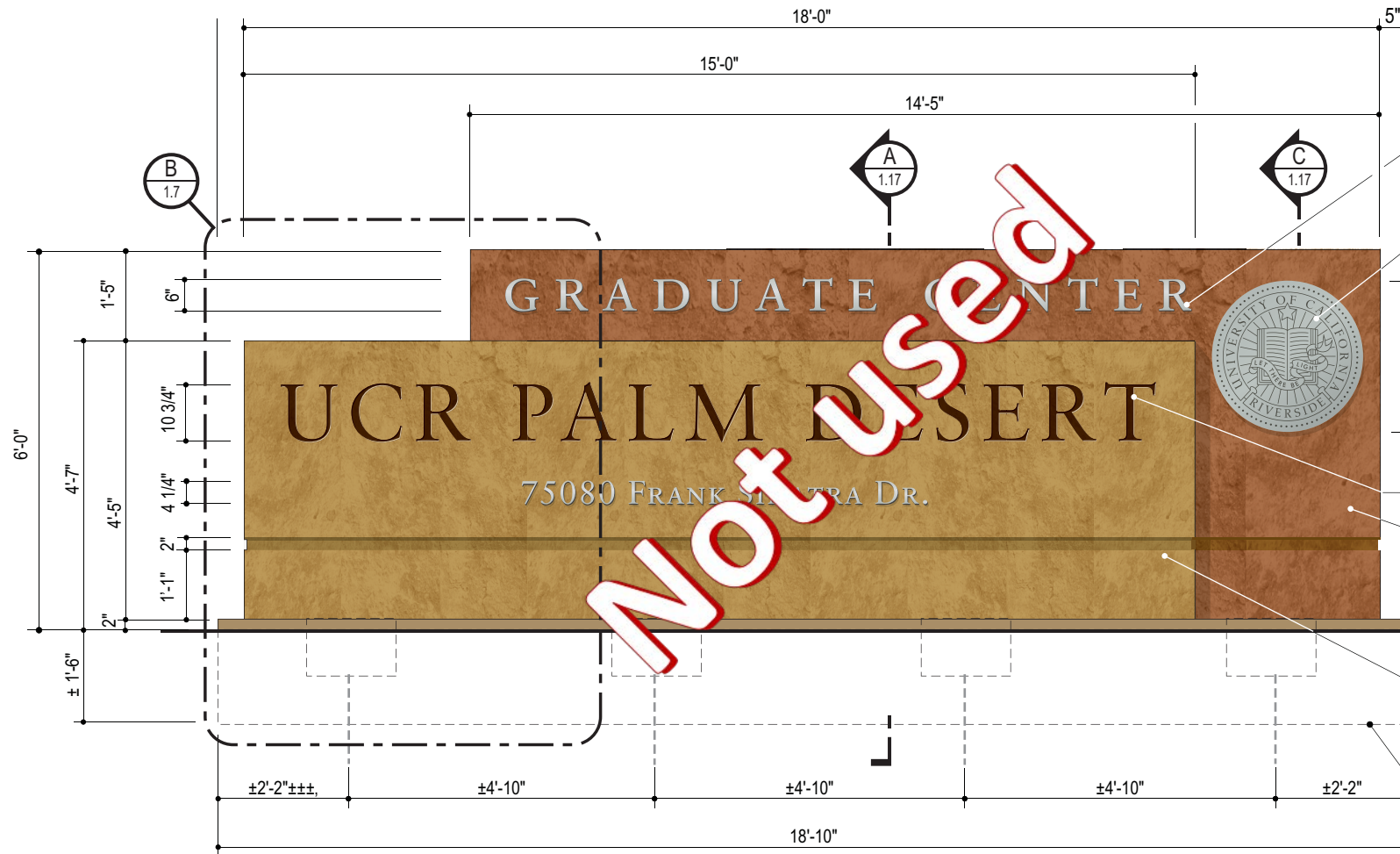
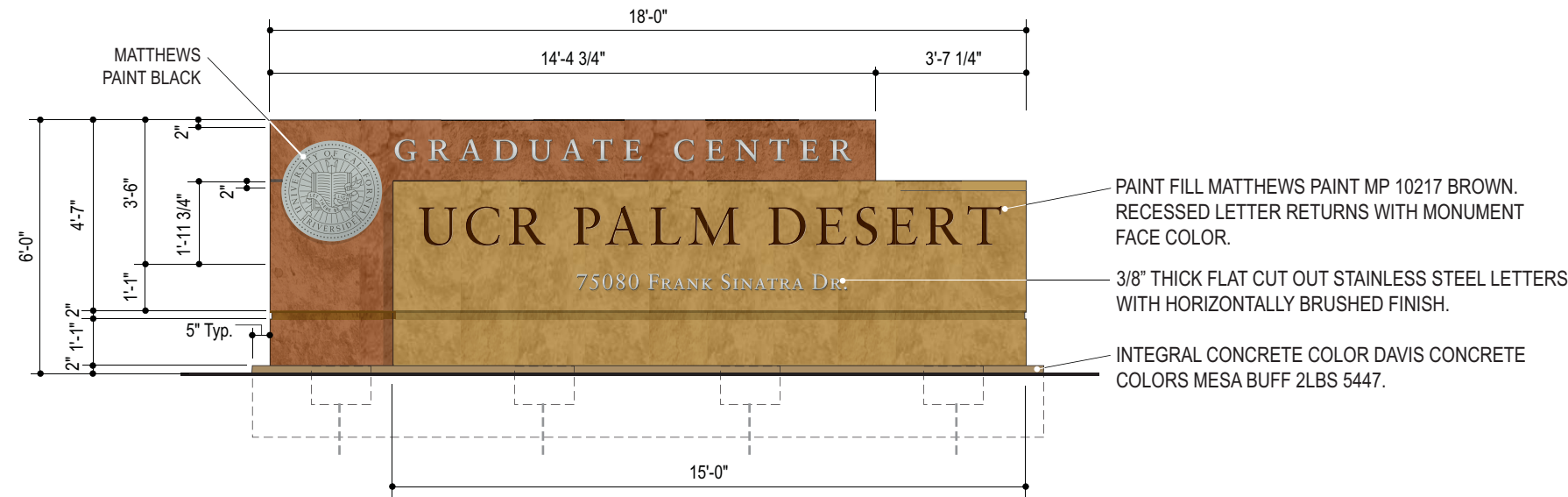

Not Used

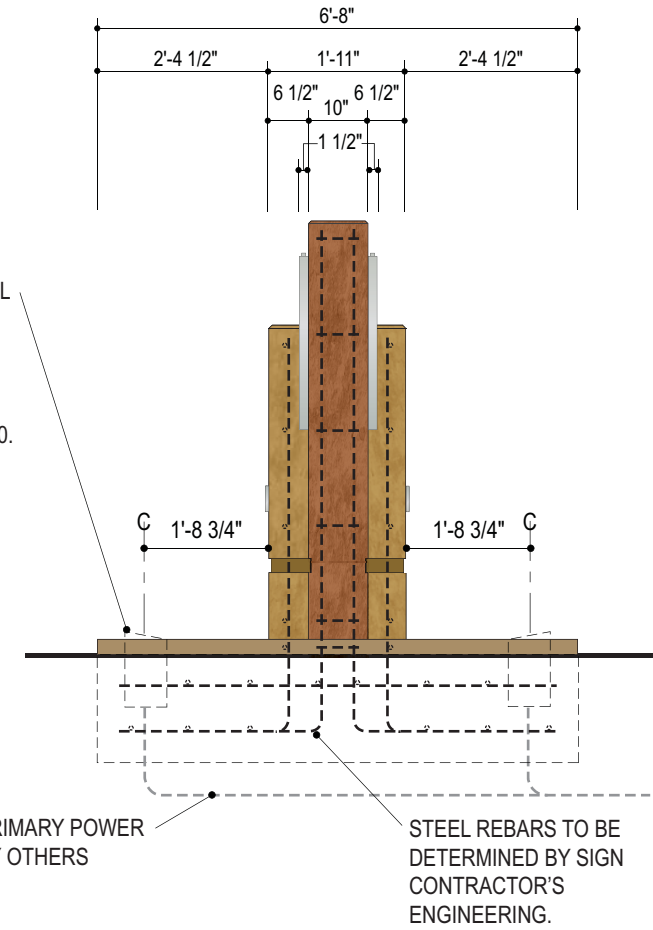

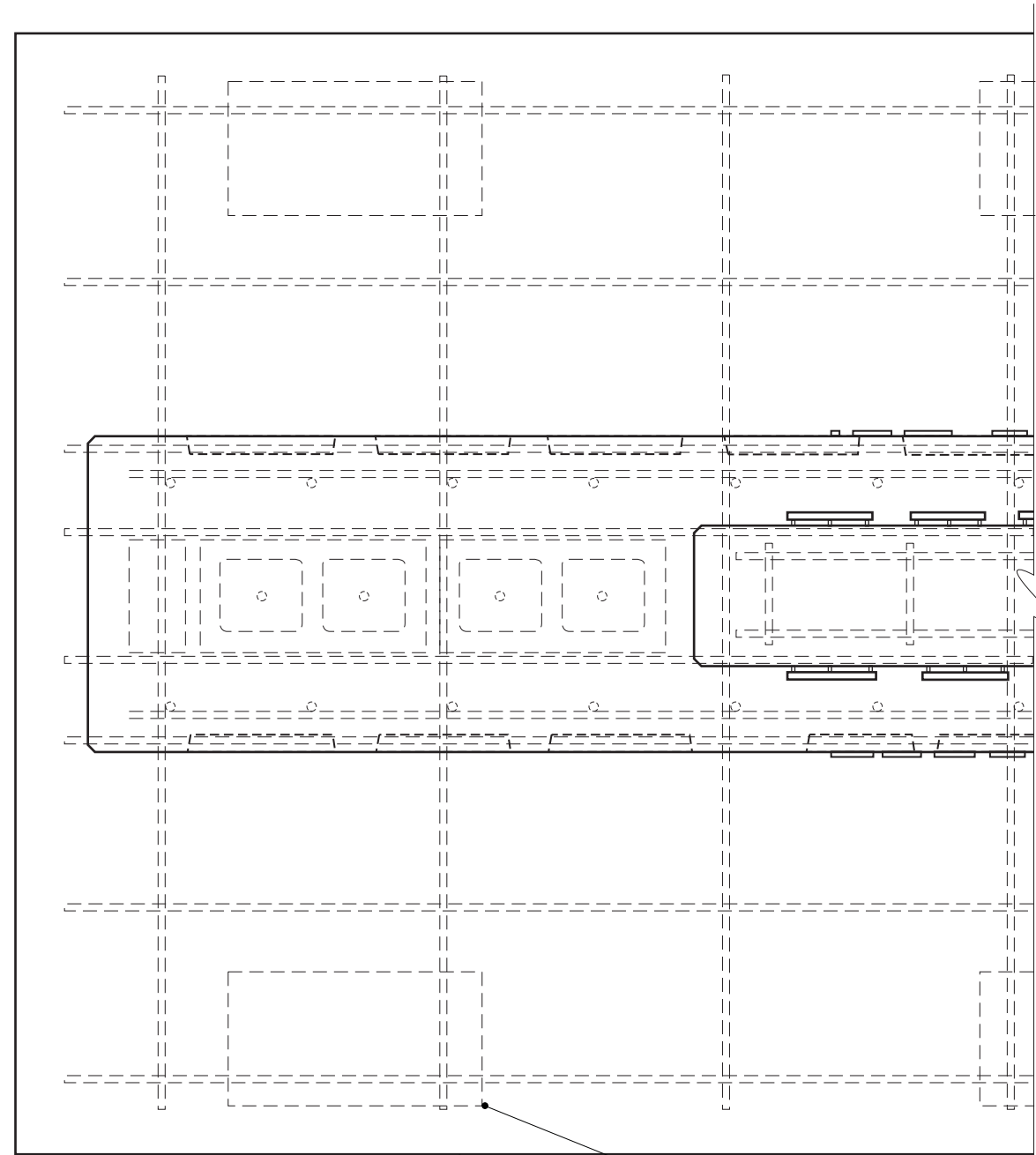

PARTIAL PLAN DETAIL 1" = 1'-0" (B)

GENERAL NOTES:
 1. SIGN CONSTRUCTION DETAILS CONCEPTUAL ONLY, SIGN CONTRACTOR'S ENGINEERING TO TAKE PRECEDENCE OVER ANY DRAWING DETAILS.
 2. STONE AND OR COLOR MATCHES CAN BE PURCHASED THROUGH CONTRACTOR'S TILE MART, 1063 E. LAS TUNAS DR., SAN GABRIEL, CALIF. 91776 - TEL. (626) 287-6483 - ATTN. ALBERT MALOOF

ARIDA FLUORESCENT OUTDOOR ARCHITECTURAL LIGHTING OR EQUIVALENT. SIGN CONTRACTOR TO MINIMIZE FIXTURES ABOVE GRADE AND STILL SECURE EVEN ILLUMINATION. RECOMMENDED LIGHTING CONSULTANT, MARGIE CHAVEZ, PRUDENTIAL LIGHTING PRODUCTS, (213) 746-0360.

CONCRETE FOOTING AND REBARS AS PER SIGN CONTRACTOR'S ENGINEERING WITH INTEGRAL COLORED CONCRETE MOW PAD. PRIMARY POWER BY OTHERS.

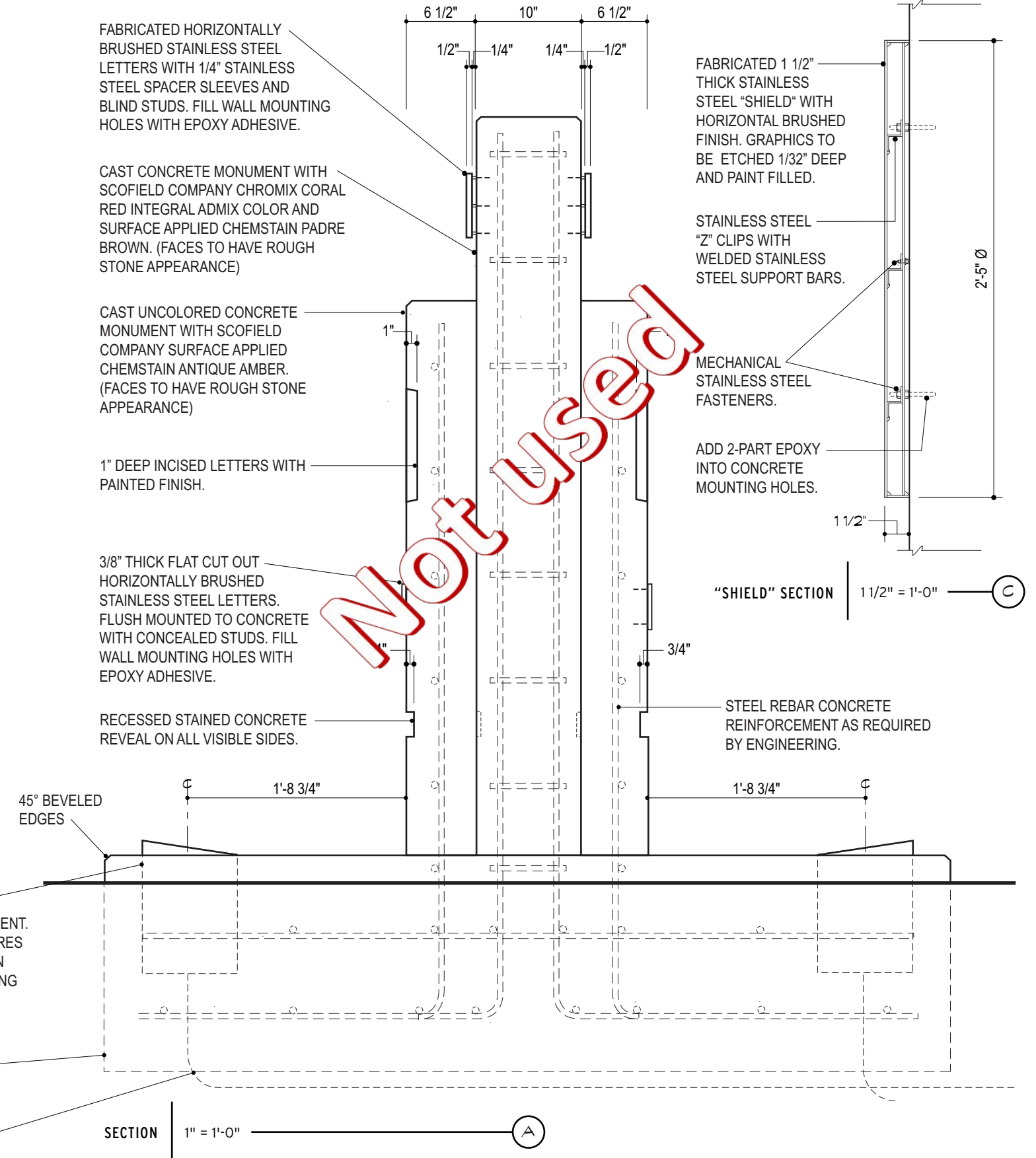

FABRICATED HORIZONTALLY BRUSHED STAINLESS STEEL LETTERS WITH 1/4" STAINLESS STEEL SPACER SLEEVES AND BLIND STUDS. FILL WALL MOUNTING HOLES WITH EPOXY ADHESIVE.

CAST CONCRETE MONUMENT WITH SCOFIELD COMPANY CHROMIX CORAL RED INTEGRAL ADMIX COLOR AND SURFACE APPLIED CHEMSTAIN PADRE BROWN. (FACES TO HAVE ROUGH STONE APPEARANCE)

CAST UNCOLORED CONCRETE MONUMENT WITH SCOFIELD COMPANY SURFACE APPLIED CHEMSTAIN ANTIQUE AMBER. (FACES TO HAVE ROUGH STONE APPEARANCE)

1" DEEP INCISED LETTERS WITH PAINTED FINISH.

3/8" THICK FLAT CUT OUT HORIZONTALLY BRUSHED STAINLESS STEEL LETTERS. FLUSH MOUNTED TO CONCRETE WITH CONCEALED STUDS. FILL WALL MOUNTING HOLES WITH EPOXY ADHESIVE.

RECESSED STAINED CONCRETE REVEAL ON ALL VISIBLE SIDES.

45° BEVELED EDGES

SECTION 1" = 1'-0" (A)

6 1/2" 10" 6 1/2"
 1/2" 1/4" 1/4" 1/2"

FABRICATED 1 1/2" THICK STAINLESS STEEL "SHIELD" WITH HORIZONTAL BRUSHED FINISH. GRAPHICS TO BE ETCHED 1/32" DEEP AND PAINT FILLED.

STAINLESS STEEL "Z" CLIPS WITH WELDED STAINLESS STEEL SUPPORT BARS.

MECHANICAL STAINLESS STEEL FASTENERS.

ADD 2-PART EPOXY INTO CONCRETE MOUNTING HOLES.

"SHIELD" SECTION 1 1/2" = 1'-0" (C)

STEEL REBAR CONCRETE REINFORCEMENT AS REQUIRED BY ENGINEERING.

NOT USED

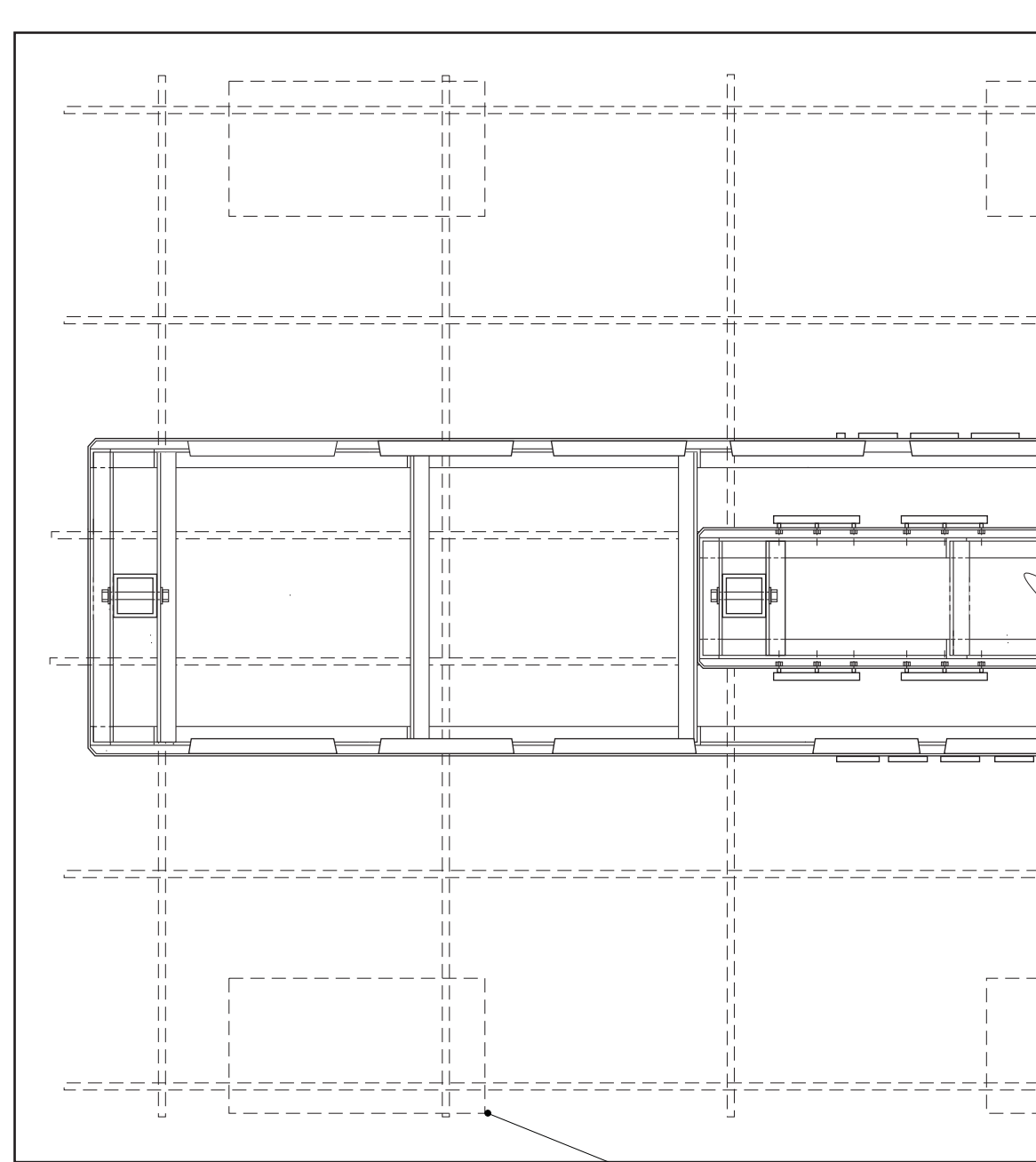

PARTIAL PLAN DETAIL

1" = 1'-0"



GENERAL NOTES:

1. SIGN CONSTRUCTION DETAILS CONCEPTUAL ONLY, SIGN CONTRACTOR'S ENGINEERING TO TAKE PRECEDENCE OVER ANY DRAWING DETAILS.
2. STONE AND OR COLOR MATCHES CAN BE PURCHASED THROUGH CONTRACTOR'S TILE MART, 1063 E. LAS TUNAS DR., SAN GABRIEL, CALIF. 91776 - TEL. (626) 287-6483 - ATTN. ALBERT MALOOF

ARIDA FLUORESCENT OUTDOOR ARCHITECTURAL LIGHTING OR EQUIVALENT. SIGN CONTRACTOR TO MINIMIZE FIXTURES ABOVE GRADE AND STILL SECURE EVEN ILLUMINATION. RECOMMENDED LIGHTING CONSULTANT, MARGIE CHAVEZ, PRUDENTIAL LIGHTING PRODUCTS, (213) 746-0360.

CONCRETE FOOTING AND REBARS AS PER SIGN CONTRACTOR'S ENGINEERING WITH INTEGRAL COLORED CONCRETE MOW PAD. PRIMARY POWER BY OTHERS.

45° BEVELED EDGES

SECTION

1" = 1'-0"

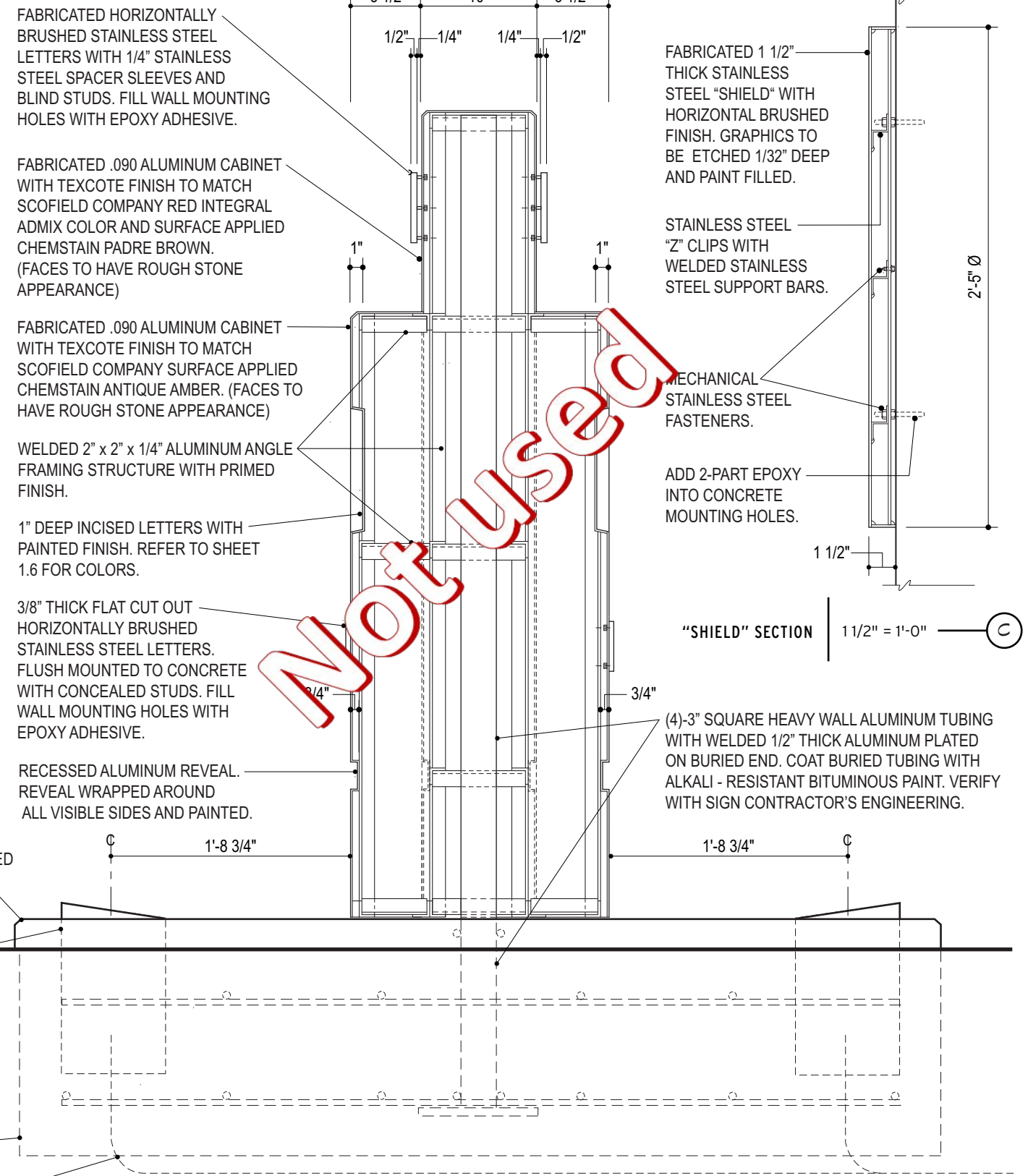

FABRICATED HORIZONTALLY BRUSHED STAINLESS STEEL LETTERS WITH 1/4" STAINLESS STEEL SPACER SLEEVES AND BLIND STUDS. FILL WALL MOUNTING HOLES WITH EPOXY ADHESIVE.

FABRICATED .090 ALUMINUM CABINET WITH TEXCOTE FINISH TO MATCH SCOFIELD COMPANY RED INTEGRAL ADMIX COLOR AND SURFACE APPLIED CHEMSTAIN PADRE BROWN. (FACES TO HAVE ROUGH STONE APPEARANCE)

FABRICATED .090 ALUMINUM CABINET WITH TEXCOTE FINISH TO MATCH SCOFIELD COMPANY SURFACE APPLIED CHEMSTAIN ANTIQUE AMBER. (FACES TO HAVE ROUGH STONE APPEARANCE)

WELDED 2" x 2" x 1/4" ALUMINUM ANGLE FRAMING STRUCTURE WITH PRIMED FINISH.

1" DEEP INCISED LETTERS WITH PAINTED FINISH. REFER TO SHEET 1.6 FOR COLORS.

3/8" THICK FLAT CUT OUT HORIZONTALLY BRUSHED STAINLESS STEEL LETTERS. FLUSH MOUNTED TO CONCRETE WITH CONCEALED STUDS. FILL WALL MOUNTING HOLES WITH EPOXY ADHESIVE.

RECESSED ALUMINUM REVEAL. REVEAL WRAPPED AROUND ALL VISIBLE SIDES AND PAINTED.

6 1/2" 10" 6 1/2"
1/2" 1/4" 1/4" 1/2"

FABRICATED 1 1/2" THICK STAINLESS STEEL "SHIELD" WITH HORIZONTAL BRUSHED FINISH. GRAPHICS TO BE ETCHED 1/32" DEEP AND PAINT FILLED.

STAINLESS STEEL "Z" CLIPS WITH WELDED STAINLESS STEEL SUPPORT BARS.

MECHANICAL STAINLESS STEEL FASTENERS.

ADD 2-PART EPOXY INTO CONCRETE MOUNTING HOLES.

1 1/2"

2'-5" Ø

"SHIELD" SECTION

1 1/2" = 1'-0"



(4)-3" SQUARE HEAVY WALL ALUMINUM TUBING WITH WELDED 1/2" THICK ALUMINUM PLATED ON BURIED END. COAT BURIED TUBING WITH ALKALI - RESISTANT BITUMINOUS PAINT. VERIFY WITH SIGN CONTRACTOR'S ENGINEERING.

1'-8 3/4"

1'-8 3/4"

3/4"

1'-8 3/4"

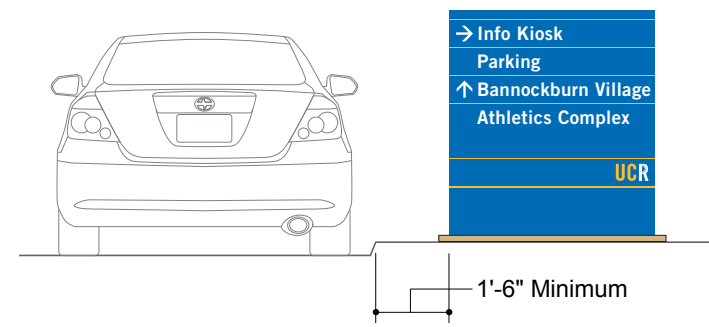

LOCATION ELEVATION | 1/4" = 1'-0"

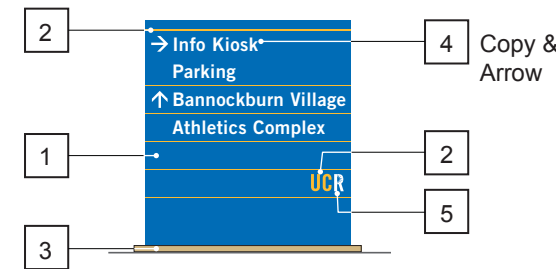

COLOURS | 1/4" = 1'-0"
 Note: All sign surfaces to be sprayed with semi gloss anti graffiti clear coating.

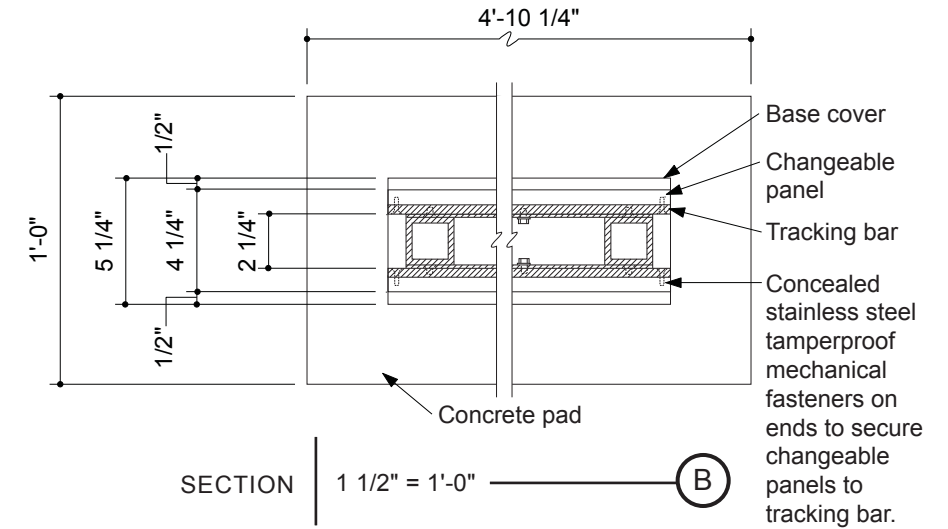

SECTION | 1 1/2" = 1'-0" (B)

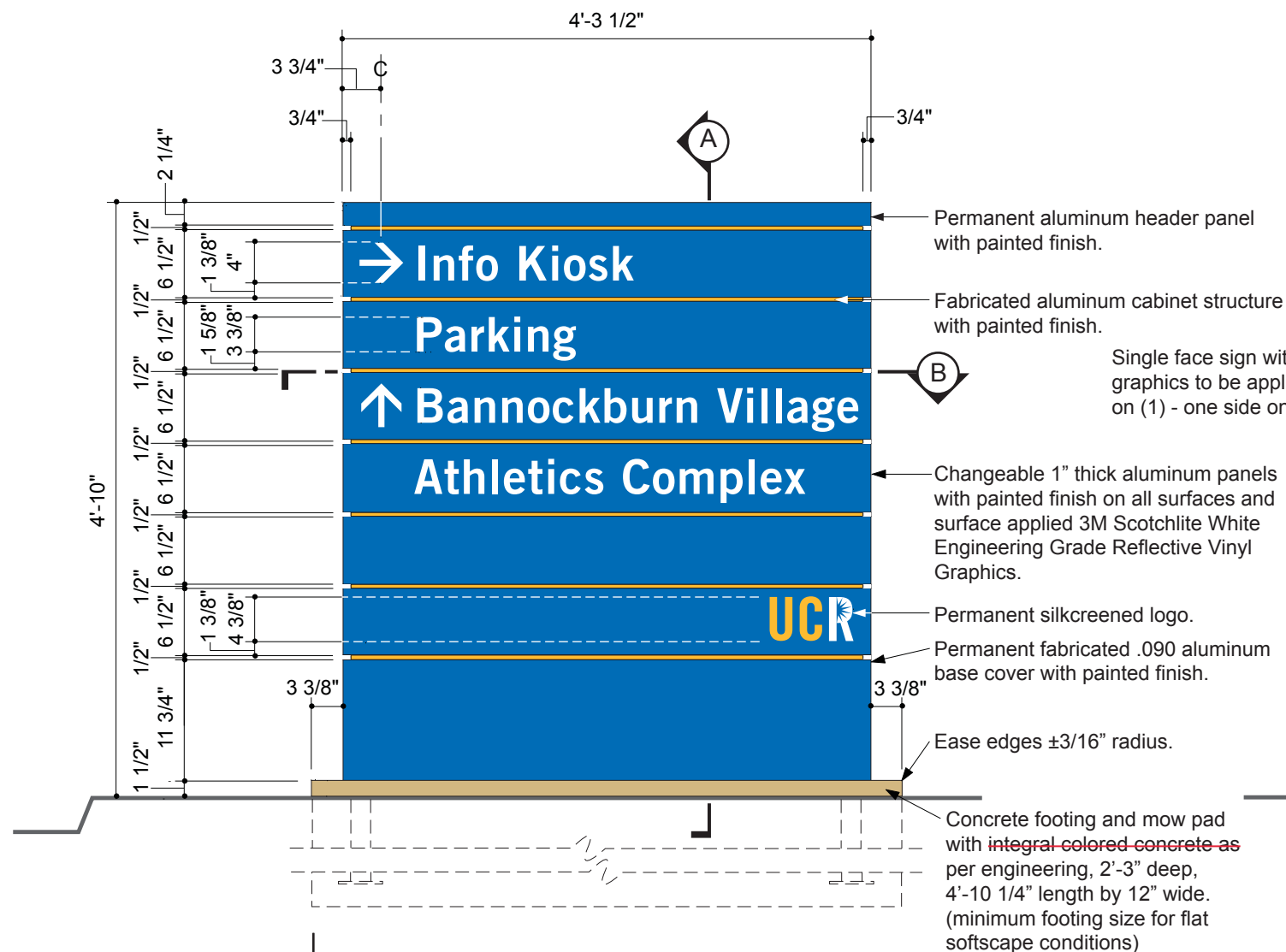

ELEVATION | 3/4" = 1'-0"

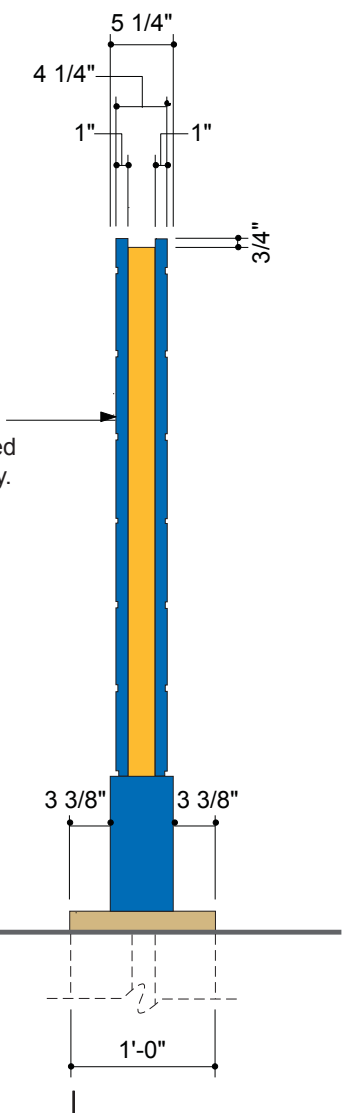

SIDE VIEW | 3/4" = 1'-0"

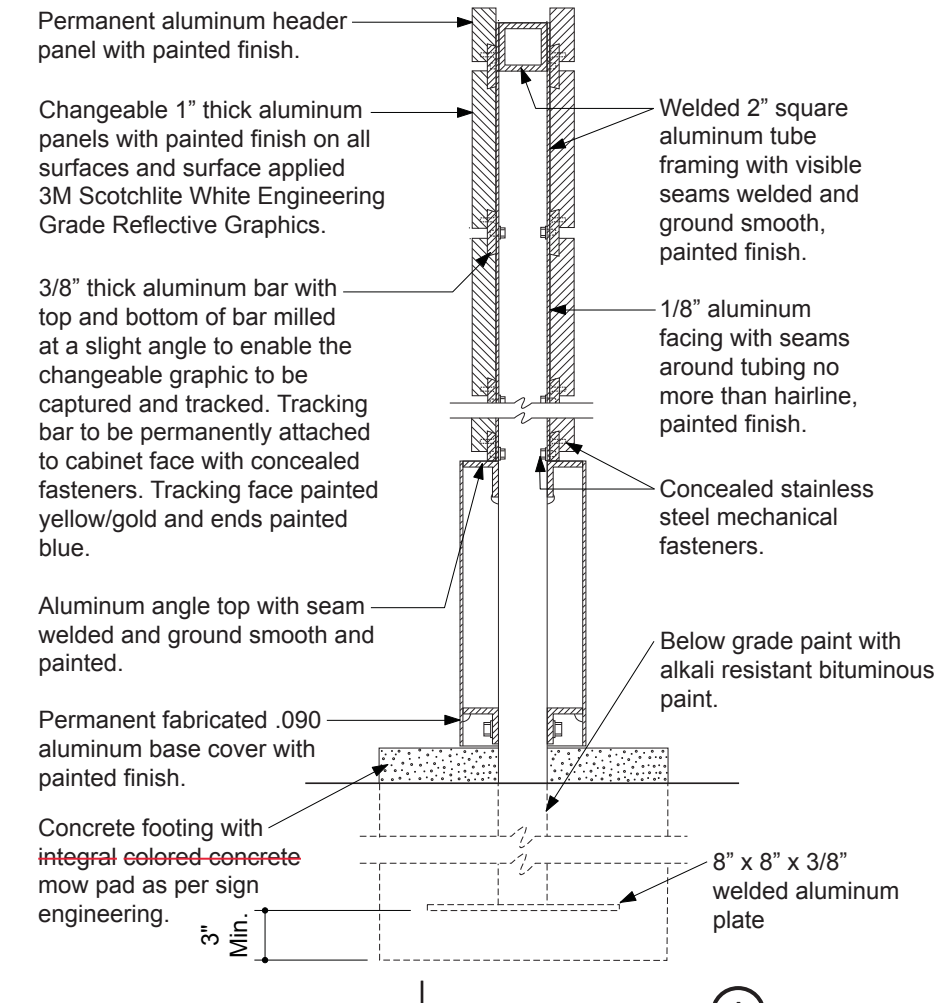

SECTION | 1 1/2" = 1'-0" (A)

HUNT DESIGN
25 N. MENTOR AVE.
PASADENA, CA 91106

PAGE: 1 of 2
PROJECT: UC RIVERSIDE
SUBJECT: RIVERSIDE, CA
SIGN STRUCTURAL CALCS.
BY: DVM DATE: 10-1-07
P.O.# DWGS. FROM PERRY SHIMOJI

FOR COLUMN & FOOTING DESIGN

AREA -- SIGN TYPE W20.0
A= 4.83' * 4.29' = 20.7 S.F.

WIND CBC-'01 80 MPH, EXP. C

CBC-1613 $p=Cq*Ce*Qs*I$ I=1.0
 $Qs = 16.4$ $Cq = 1.4$
 25.94 LBS/S.F. @ 20' $Ce = 1.13$
 24.34 LBS/S.F. < 15' $Ce = 1.06$
 S.F. LBS FT. FT. LBS
 AREA !PRESS! X-DIST ! MOM-XX

20.7	504	2.42	1219
0.0	0	0.00	0
0.0	0	0.00	0
0.0	0	0.00	0

TOTAL 504 2.42 1219 (AVE.)

DOUBLE COLUMN MOM. 'K 0.61

ALUM $Fb = 12$ K/SQ. IN.
 $S = M/Fb$ WIND 1/3 INCR.
 $S = 0.75 * M$ (INCL 1.33 WIND)
 $S = 0.46$ IN³

$S = (bd^3 - b1*d1^3)/(6*d)$
 $d = 2$ $d1 = 1.75$
 $b = 2$ $b1 = 1.75$
 USING 2"x2"x 1/8" ALUM. TUBE
 $S = 0.55$ IN³ > 0.46 O.K.

COAT ALUM. SURFACES EMBEDDED IN CONC. WITH ONE HEAVY COAT OF ALKALI-RESISTANT BITUMINOUS (BITUMASTIC) PAINT TO 2" MIN. ABOVE GRADE
 8"x8"x 3/8" ALUM. PLATE - W/4000 WT. OF SIGN = 220 LBS +/- AXIAL STRESS IS NEGLIGIBLE

SEE PAGE 2 FOR FOOTING DETAILS

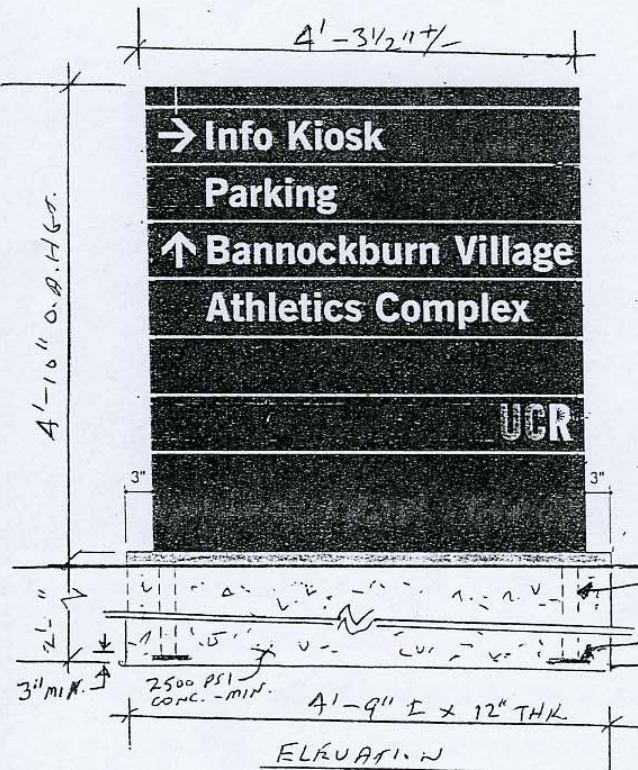

JOB NO. HUNT-142

HUNT DESIGN
25 N. MENTOR AVE.
PASADENA, CA 91106

PAGE: 2 of 2
PROJECT: UC RIVERSIDE
SUBJECT: RIVERSIDE, CA
SIGN STRUCTURAL CALCS.
BY: DVM DATE: 10-1-07
P.O.# DWGS. FROM PERRY SHIMOJI

SINGLE FOOTING - STRAIGHT

DESIGN OF EMBEDDED POLE FOOTINGS

DESCRIPTION	>>	57" WIDE		
	>>	12" THK		
ALLOW PASSIVE	psf	200	200	200
MAX PASSIVE	psf	1,500	1,500	1,500
LOAD DURATION FACTOR		1.33	1.33	1.33
POINT LOAD	lbs	504	0	0
LOAD HT.	ft	2.42	0.00	0.00
DIST. LOAD	#/ft	0	0	0
START HT.	ft	0.00	0.00	0.00
END HT.	ft	0.00	0.00	0.00
WIDTH/DIAMETER	in	57"	0	0
CIRCULAR ?	y/n	N	N	N
RESTRAINED ?	y/n	N	N	N
SUMMARY				
Moments @ Surface:				
Point Load	ft-#	1,220	0	0
Uniform Load	ft-#	0	0	0
... Total Moment	ft-#	1,220	0	0
Total Lateral Load	#	504	0	0
NON-RESTRAINED RESULTS				
Min. Req'd Embedment		2'-3"		
$A(1+(1+4.36h/A)^.5)/2$	ft	2.11	0.00	0.00
$A=2.34P/(S 1 b)$				
Press @ 1/3 Embed.:				
Actual	psf	188	0	0
Allowable	psf	187	0	0
RESTRAINED				
Min. Req'd Embedment		0.00	0.00	0.00
$(4.25 P h/S3 b)^.5$	ft			
Pressure @ Bottom				
Actual	psf	0	0	0
Allowable	psf	0	0	0
Surface Restraint Force	lbs	0	0	0

PER CBC TABLE 18-1-A
POLE 2X ALLOWABLE



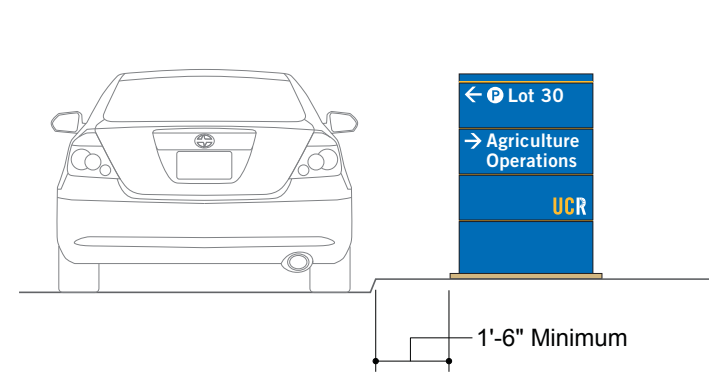

LOCATION ELEVATION | 1/4" = 1'-0"

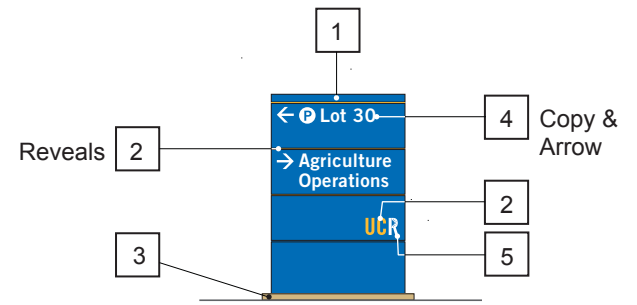

Note: All sign surfaces to be sprayed with semi gloss anti graffiti clear coating.

COLORS | 1/4" = 1'-0"

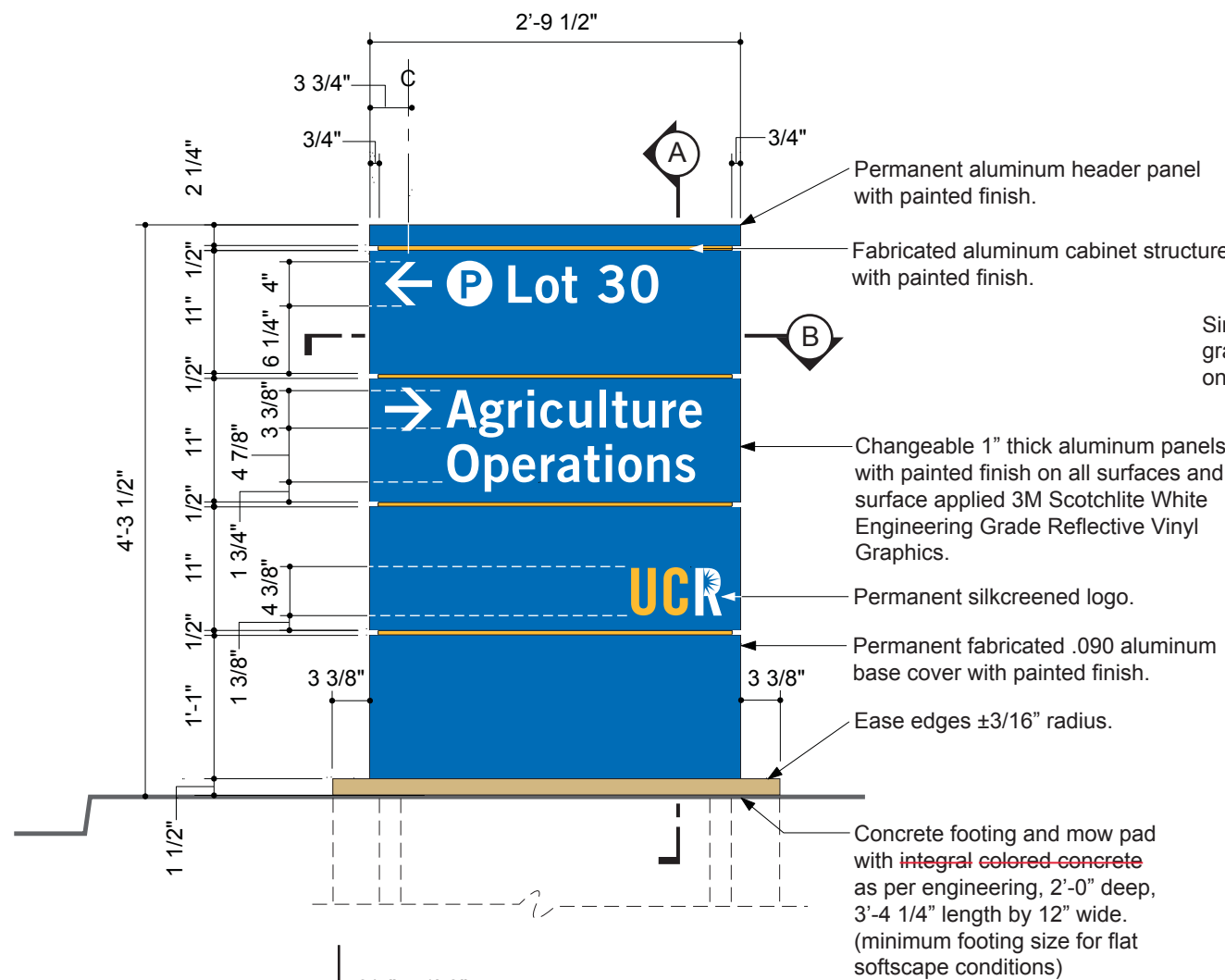
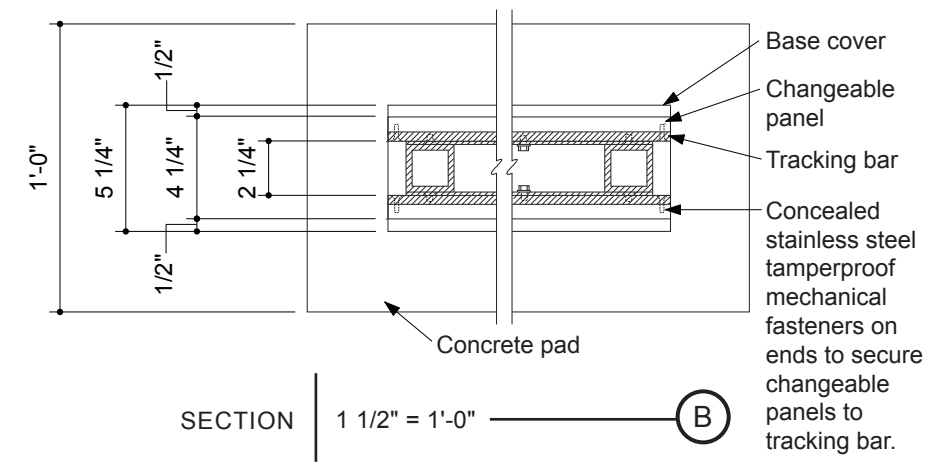

Single face sign with graphics to be applied on (1) - one side only.

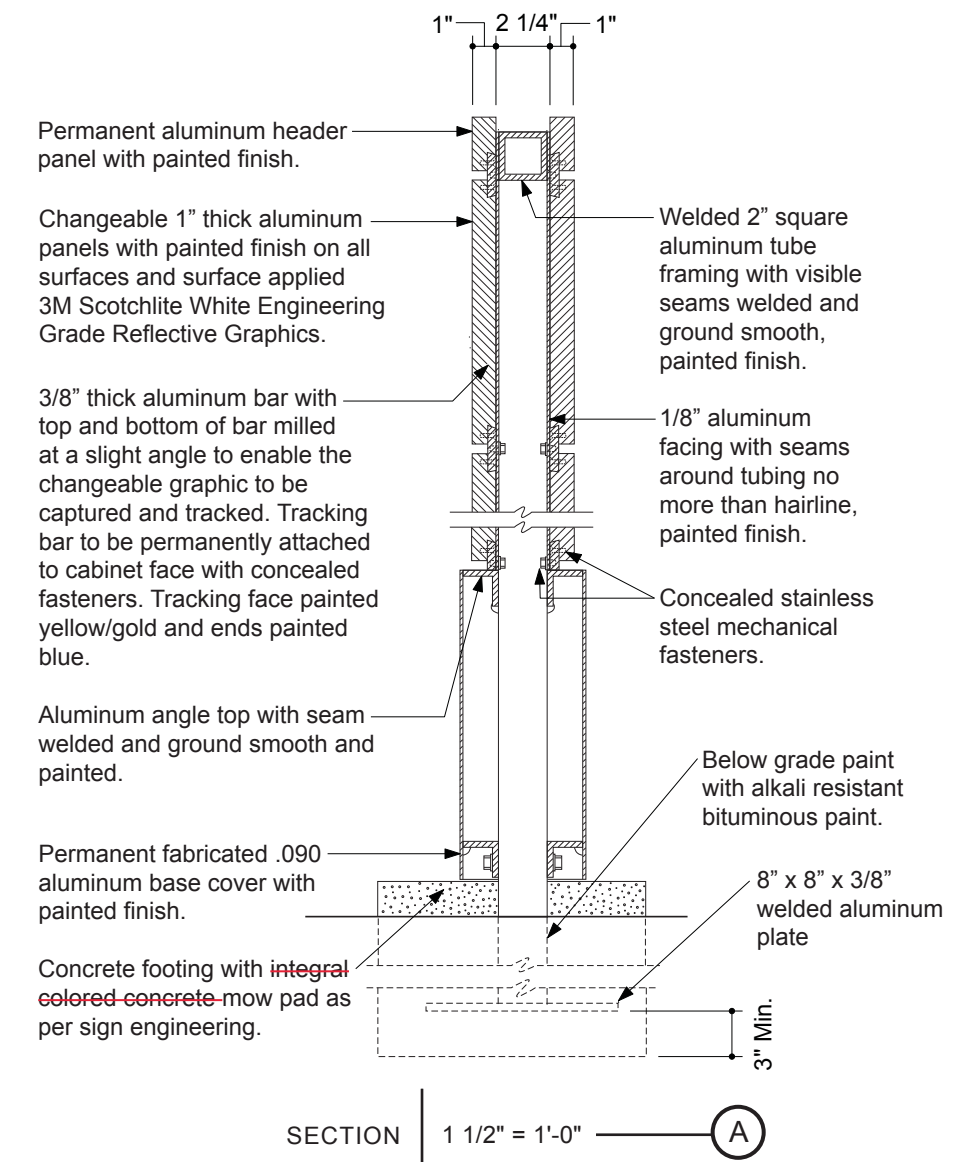
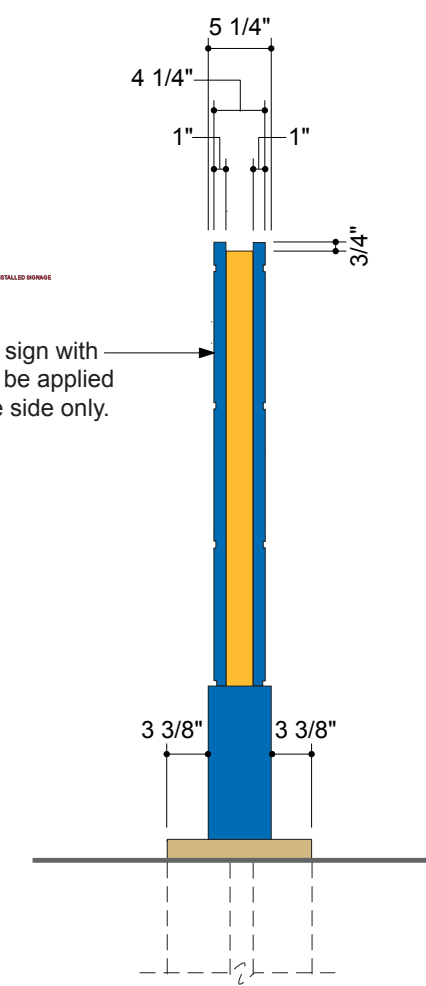

MODIFIED | MATCH EXISTING INSTALLED SIGNAGE

HUNT DESIGN
25 N. MENTOR AVE.
PASADENA, CA 91106

PAGE: 1 of 2
PROJECT: UC RIVERSIDE
SUBJECT: RIVERSIDE, CA
SIGN STRUCTURAL CALCS.
BY: DVM DATE: 10-1-07
P.O.# DWGS. FROM PERRY SHIMOJI

FOR COLUMN & FOOTING DESIGN

AREA -- SIGN TYPE W21.0
A= 4.29' * 2.79' = 12.0 S.F.

WIND CBC-'01 80 MPH, EXP. C
CBC-1613 $p=Cq*Ce*Qs*I$ I=1.0
 $Qs = 16.4$ $Cq = 1.4$
25.94 LBS/S.F. @ 20' $Ce = 1.13$
24.34 LBS/S.F. < 15' $Ce = 1.06$
S.F. LBS FT. FT. LBS
AREA | PRESS | X-DIST | MOM-XX

12.0	292	2.15	628
0.0	0	0.00	0
0.0	0	0.00	0
0.0	0	0.00	0

TOTAL 292 2.15 628
(AVE.)
DOUBLE COLUMN
MOM.'K 0.31

ALUM $F_b = 12$ K/SQ. IN.
 $S = M/F_b$ WIND 1/3 INCR.
 $S = 0.75 * M$ (INCL 1.33 WIND)
 $S = 0.24$ IN³
 $S = (bd^3 - b1*d1^3)/(6*d)$
 $d = 2$ $d1 = 1.75$
 $b = 2$ $b1 = 1.75$
USING 2"x2"x 1/8" ALUM. TUBE
 $S = 0.55$ IN³ > 0.24

8" x 8" x 3/8" ALUM PLATE - WRAPPED
COAT ALUM. SURFACES EMBEDDED IN
CONC. WITH ONE HEAVY COAT OF
ALKALI-RESISTANT BITUMINOUS
(BITUMASTIC) PAINT TO 2" MIN.
ABOVE GRADE

WT. OF SIGN = 130 LBS +/-
AXIAL STRESS IS NEGLIGIBLE

SEE PAGE 2 FOR FOOTING DETAILS

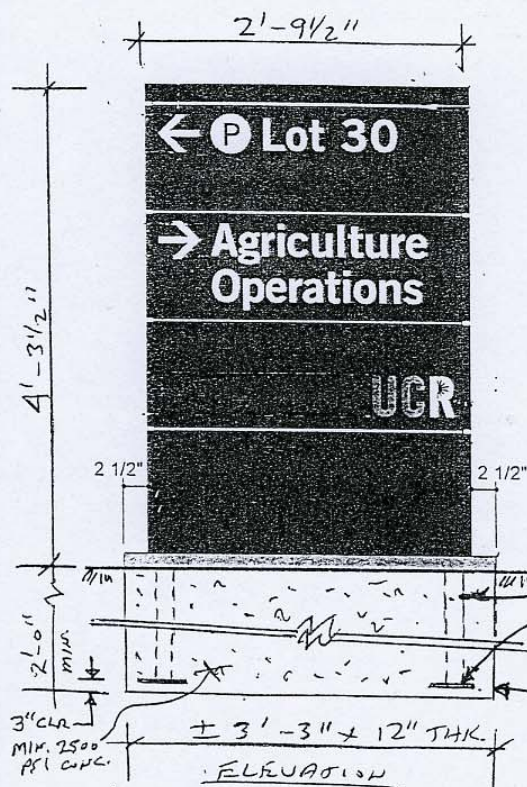
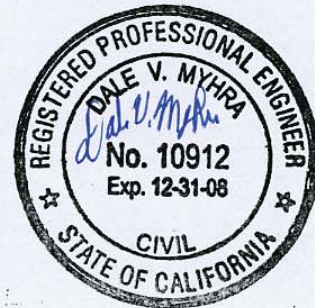

JOB NO. HUNT-143

HUNT DESIGN
25 N. MENTOR AVE.
PASADENA, CA 91106

PAGE: 2 of 2
PROJECT: UC RIVERSIDE
SUBJECT: RIVERSIDE, CA
SIGN STRUCTURAL CALCS.
BY: DVM DATE: 10-1-07
P.O.# DWGS. FROM PERRY SHIMOJI

SINGLE FOOTING - SORRIGED

DESIGN OF EMBEDDED POLE FOOTINGS

DESCRIPTION	>>	39" WIDE x 12" THK.		
ALLOW PASSIVE	psf	200	200	200
MAX PASSIVE	psf	1,500	1,500	1,500
LOAD DURATION FACTOR		1.33	1.33	1.33
POINT LOAD	lbs	292	0	0
LOAD HT.	ft	2.15	0.00	0.00
DIST. LOAD	#/ft	0	0	0
START HT.	ft	0.00	0.00	0.00
END HT.	ft	0.00	0.00	0.00
WIDTH/DIAMETER	in	39"	0	0
CIRCULAR ?	y/n	N	N	N
RESTRAINED ?	y/n	N	N	N
SUMMARY				
Moments @ Surface:				
Point Load	ft-#	628	0	0
Uniform Load	ft-#	0	0	0
... Total Moment	ft-#	628	0	0
Total Lateral Load	#	292	0	0
NON-RESTRAINED RESULTS				
Min. Req'd Embedment				
$A(1+(1+4.36h/A)^.5)/2$		2'-0"		
$A=2.34P/(S 1 b)$	ft	1.93'	0.00	0.00
Press @ 1/3 Embed.:				
Actual	psf	171	0	0
Allowable	psf	171	0	0
RESTRAINED				
Min. Req'd Embedment				
$(4.25 P h/S 3 b)^.5$	ft	0.00	0.00	0.00
Pressure @ Bottom				
Actual	psf	0	0	0
Allowable	psf	0	0	0

PER CBC TABLE 18-1-A
POLE 2x ALLOWABLE



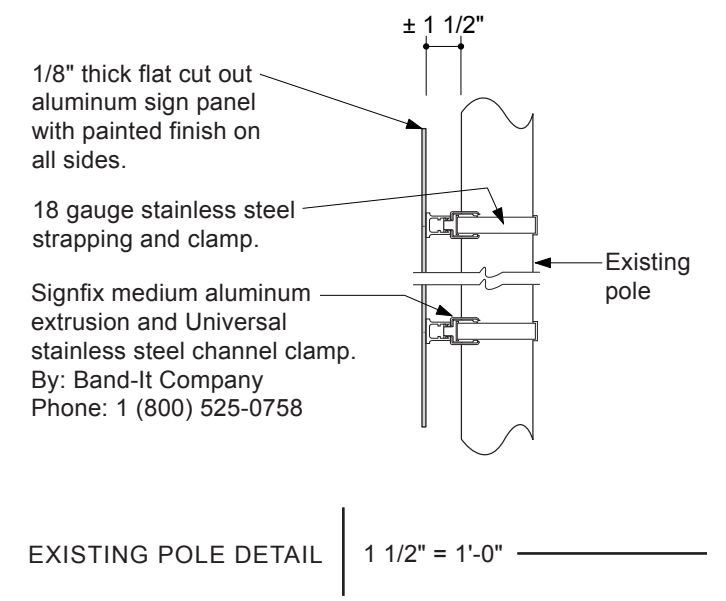
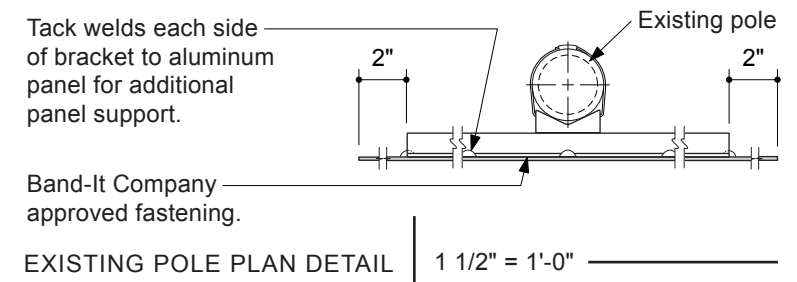
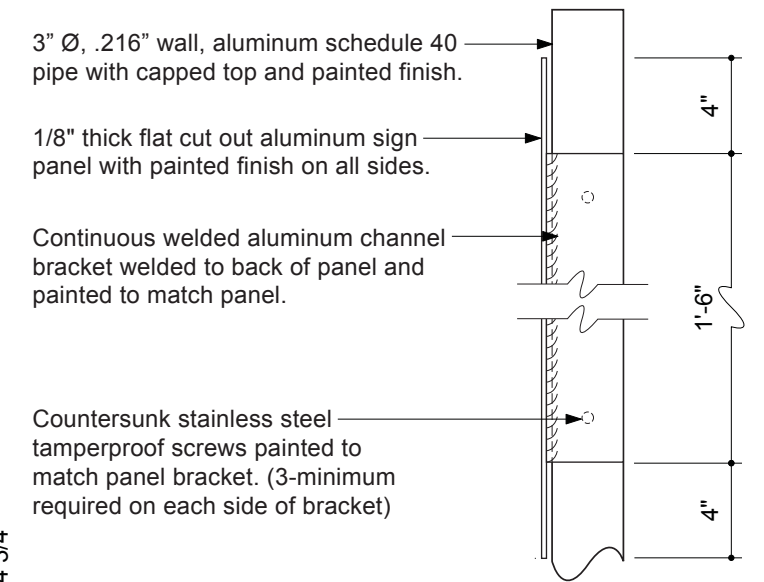
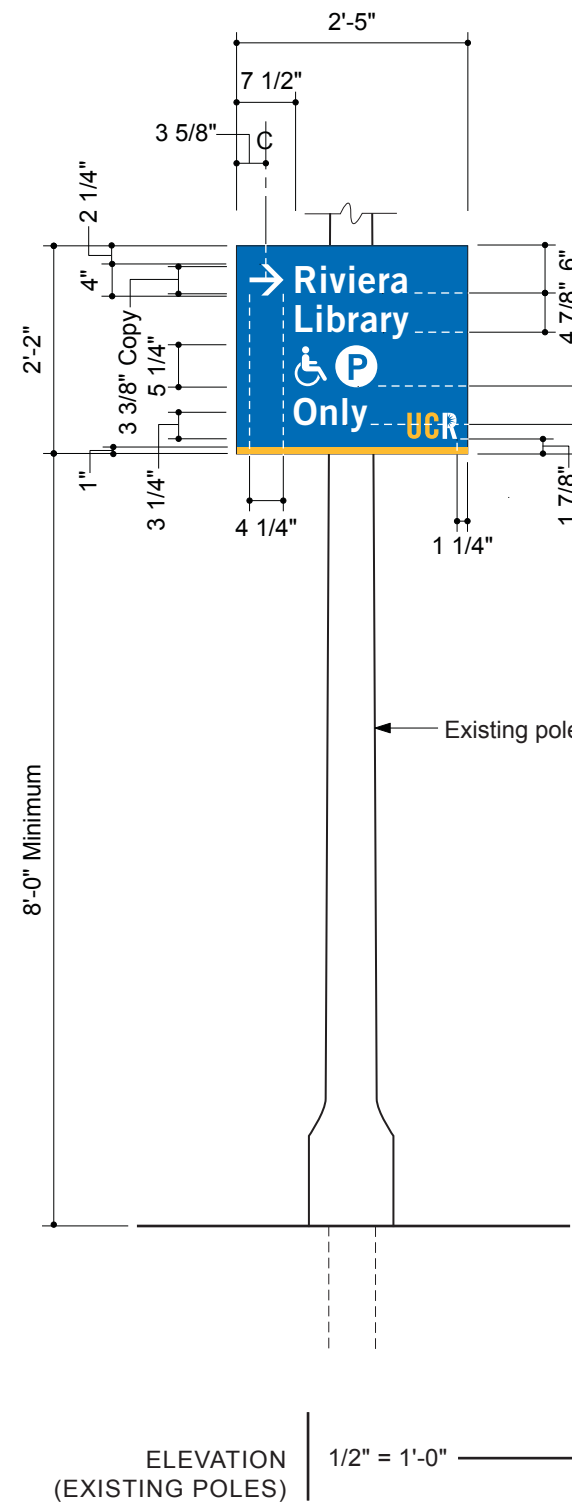
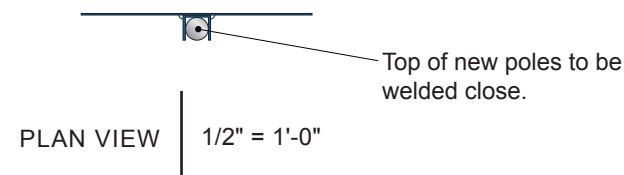
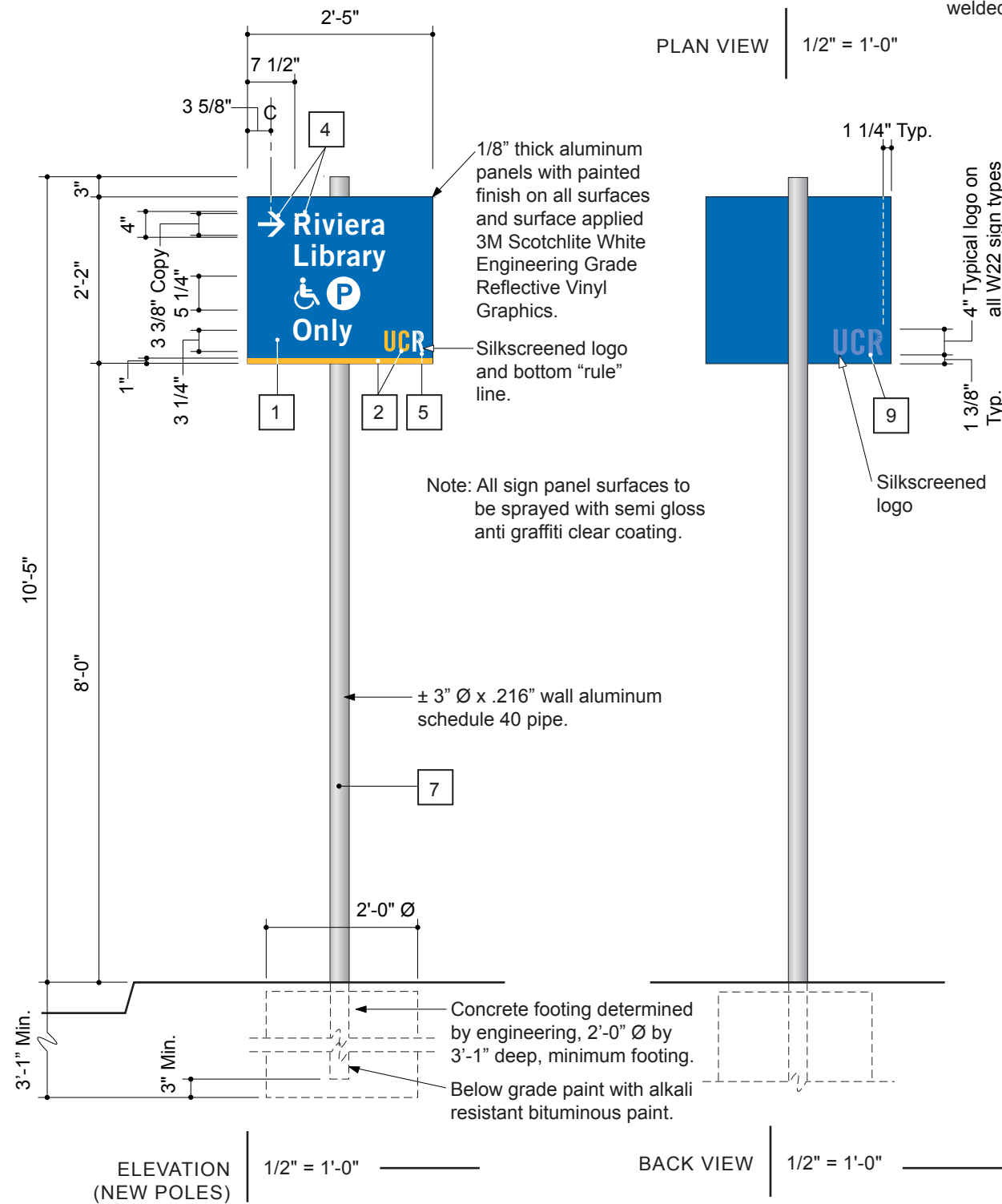

COAST SIGN, INC.
1345 S. ALLEC STREET
ANAHEIM, CA 92805

PAGE: 1 of 2
PROJECT: UC RIVERSIDE
SUBJECT: RIVERSIDE, CA
SIGN STRUCTURAL CALCS.
BY: DVM DATE: 10-3-07
P.O.# DWGS. FROM PERRY SHIMOJI

FOR COLUMN & FOOTING DESIGN

AREA -- SIGN TYPE W22.0
A = 2.25' * 2.42' = 5.4 S.F.
A = 8.17' * 0.25' = 2.0 S.F.

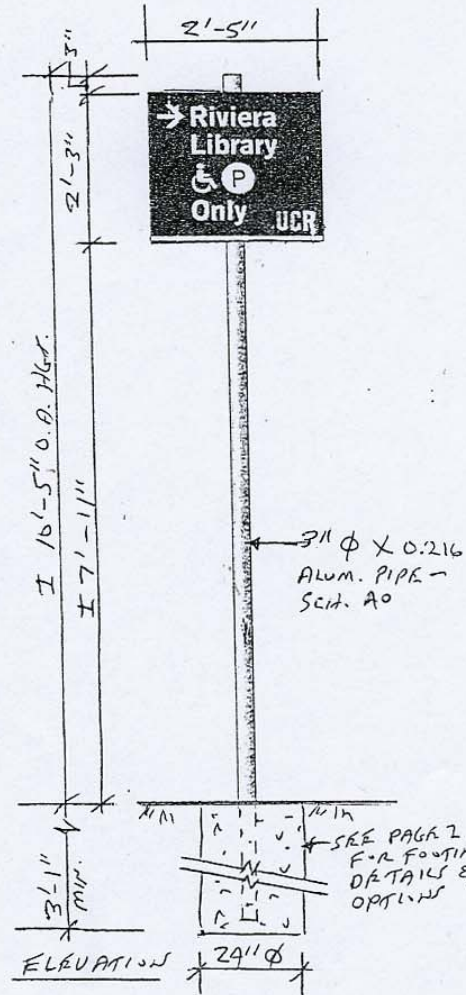

JOB NO. HUNT-145

WIND CBC-'01 80 MPH, EXP. C

CBC-1613	$p=Cq*Ce*Qs*I$	$I=1.0$	
$Qs = 16.4$	$Cq = 1.4$		
25.94	LBS/S.F. @ 20'	$Ce = 1.13$	
24.34	LBS/S.F. < 15'	$Ce = 1.06$	
S.F.	LBS	FT.	
AREA	!PRESS!	X-DIST	MOM-XX
5.4	131	9.05	1189
2.0	49	4.17	203
0.0	0	0.00	0
0.0	0	0.00	0
TOTAL	180	7.73	1392

(AVE.)

SINGLE COLUMN
MOM.'K 1.39

ALUM $F_y = 12$ K/SQ. IN.
 $S = M/F_b$ WIND 1/3 INCR.
 $S = 0.75 * M$ (INCL 1.33 WIND)
 $S = 1.04$ IN³

$t = 0.216$ IN. (MIN. THK.)
 $S = .0982*(d^4-d1^4)/d$
 $d = 3.5$ $d1 = 3.068$
USE MIN. 3" DIA. x 0.216 ALUM. PIPE #40

$S = 1.72$ IN³ > 1.04
O.K.

WT. OF SIGN = 80 LBS +/-
AXIAL STRESS IS NEGLIGIBLE

COAT ALUM. SURFACES EMBEDDED IN CONC. WITH ONE HEAVY COAT OF ALKALI-RESISTANT BITUMINOUS (BITUMASTIC PAINT -- SUCH AS HENRY'S OR EQUIVALENT).

SEE PAGE 2 FOR FOOTING DETAILS



HUNT DESIGN
25 N. MENTOR AVE.
PASADENA, CA 91106

PAGE: 2 of 2
PROJECT: UC RIVERSIDE
SUBJECT: RIVERSIDE, CA
SIGN STRUCTURAL CALCS.
BY: DVM DATE: 10-1-07
P.O.# DWGS. FROM PERRY SHIMOJI

SINGLE COLUMN

DESIGN OF EMBEDDED POLE FOOTINGS

DESCRIPTION	>>	12" DIA.	18" DIA.	24" SQ.
CHOOSE ONE	→	OPTIMUM 1	OPTIMUM 2	OPTIMUM 3
ALLOW PASSIVE	psf	200	200	200
MAX PASSIVE	psf	1,500	1,500	1,500
LOAD DURATION FACTOR		1.33	1.33	1.33
POINT LOAD	lbs	180	180	180
LOAD HT.	ft	7.73	7.73	7.73
DIST. LOAD	#/ft	0	0	0
START HT.	ft	0.00	0.00	0.00
END HT.	ft	0.00	0.00	0.00
WIDTH/DIAMETER	in	12"	18"	24"
CIRCULAR ?	y/n	Y	Y	Y
RESTRAINED ?	y/n	N	N	N
SUMMARY				
Moments @ Surface:				
Point Load	ft-#	1,391	1,391	1,391
Uniform Load	ft-#	0	0	0
... Total Moment	ft-#	1,391	1,391	1,391
Total Lateral Load	#	180	180	180
NON-RESTRAINED				
Min. Req'd Embedment		4'-0"	3'-5"	3'-1"
$A(1+(1+4.36h/A)^.5)/2$		3.88'	3.34'	3.01'
$A=2.34P/(S 1 b)$	ft			
Press. @ 1/3 Embed.:		DEPTH	DEPTH	DEPTH
Actual	psf	345	296	266
Allowable	psf	344	296	267
RESTRAINED				
Min. Req'd Embedment		0.00	0.00	0.00
$(4.25 P h/S3 b)^.5$	ft			
Pressure @ Bottom				
Actual	psf	0	0	0
Allowable	psf	0	0	0
Surface Restraint				
Force	lbs	0	0	0

PER CBC TABLE 18-
POLE 2 ALLOWABLE

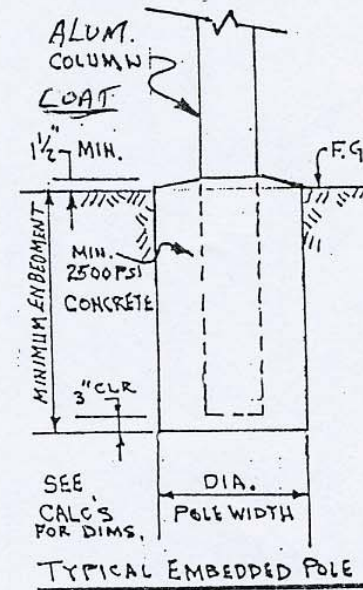

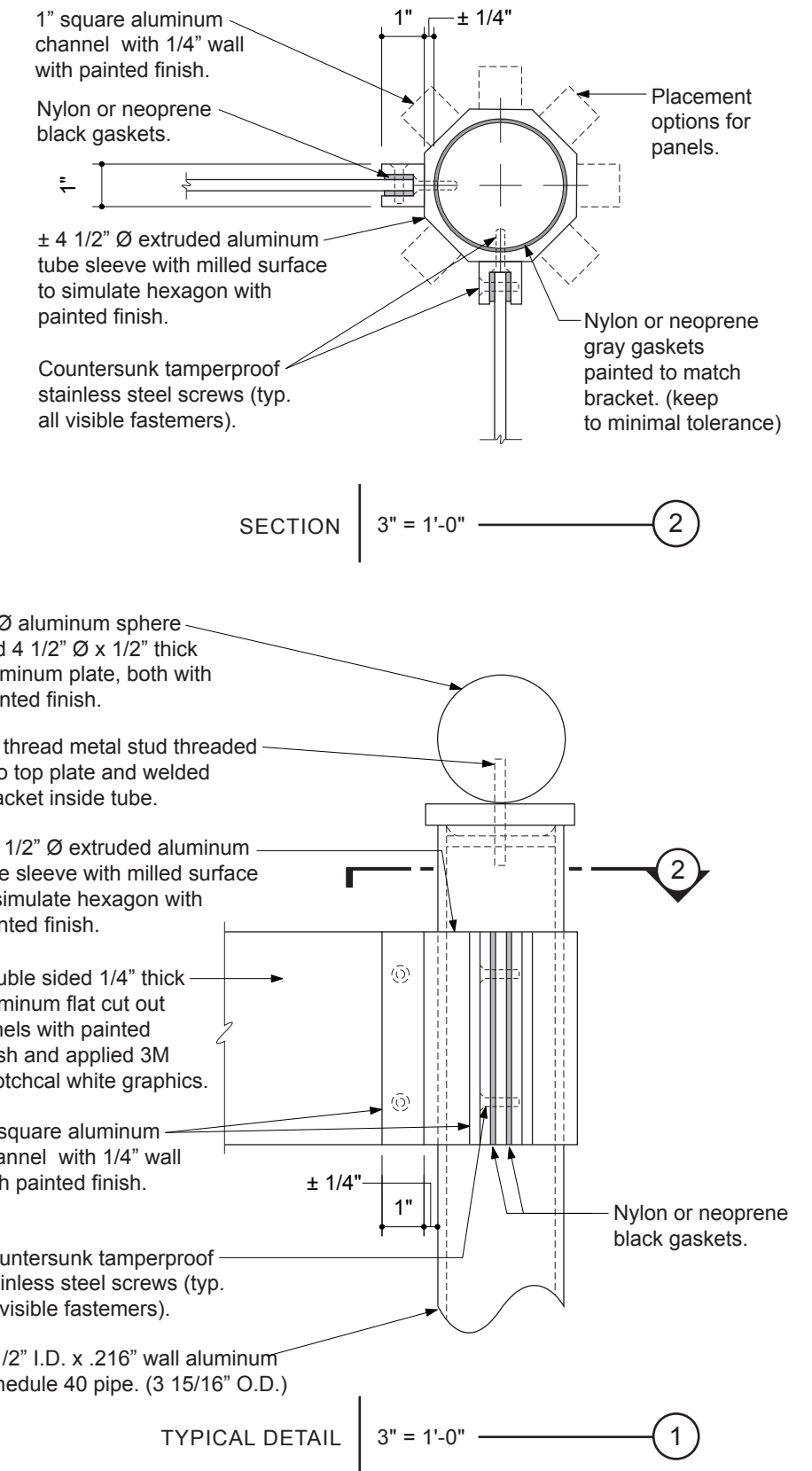
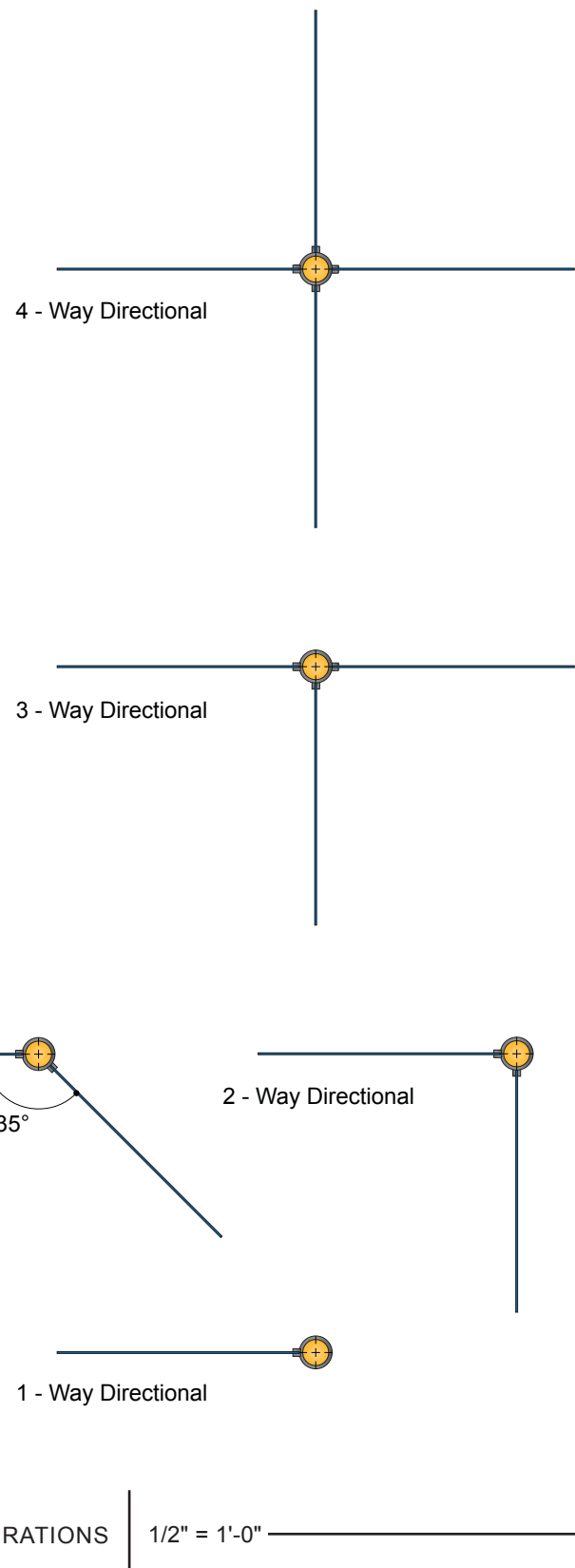
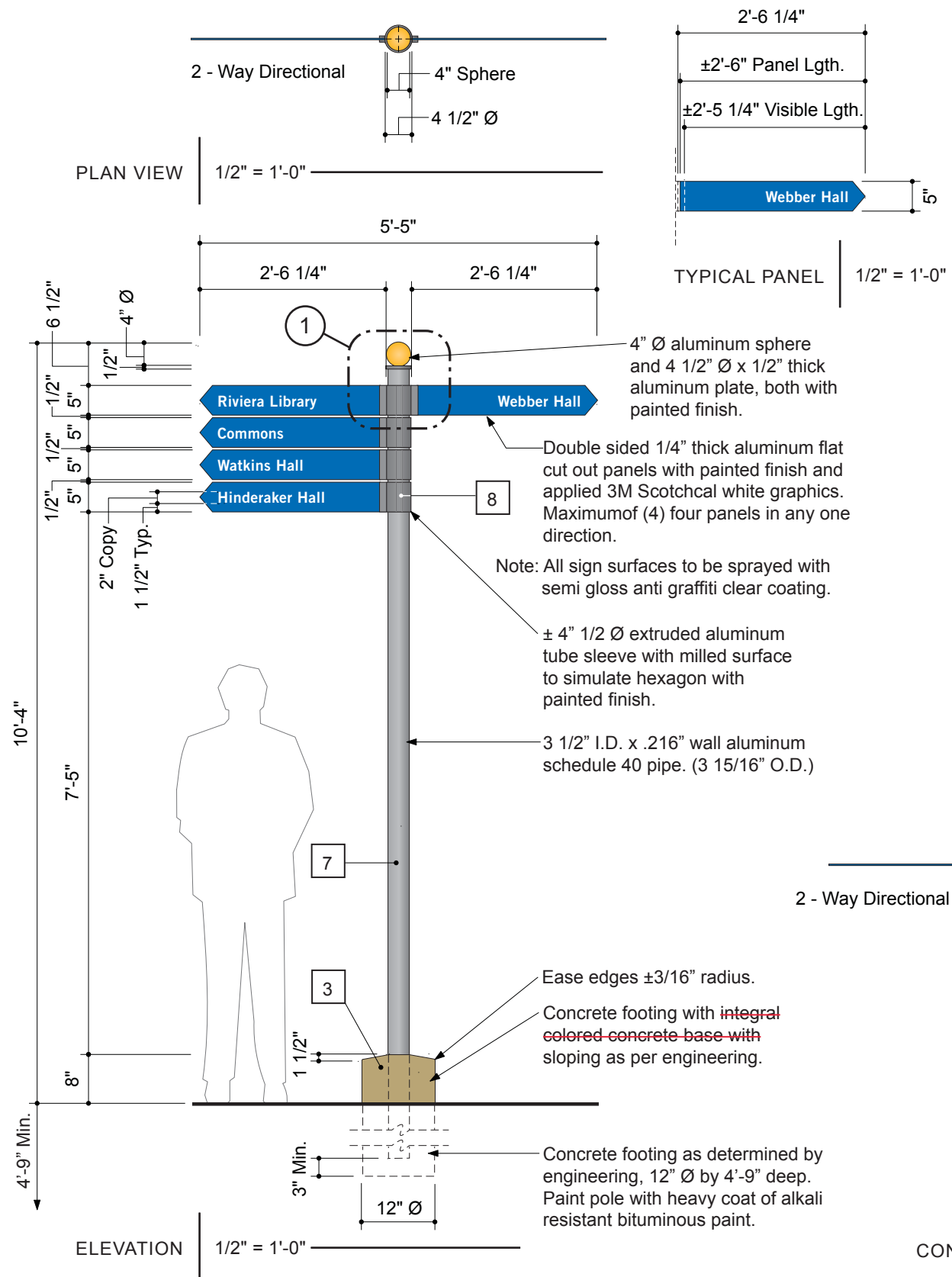

COAST SIGN, INC.
1345 S. ALLEC STREET
ANAHEIM, CA 92805

PAGE: 1 of 2
PROJECT: UC RIVERSIDE
SUBJECT: RIVERSIDE, CA
SIGN STRUCTURAL CALCS.
BY: DVM DATE: 10-3-07
P.O.# DWGS. FROM PERRY SHIMOJI

FOR COLUMN & FOOTING DESIGN

AREA -- SIGN TYPE W32.0 - DIRECTIONALS
A = 1.8' * 5.47' = 9.8 S.F. (MAX. AREA)
A = 7.86' * 0.25' = 2.0 S.F. (COL.)
A = 0.67' * 1.0' = 0.7 S.F. (BASE)

NOTE: 2-WAY DIRECTIONAL GOVERNS
FOR WIND -- OTHER CONFIGURATIONS
ARE O.K. BY INSPECTION.

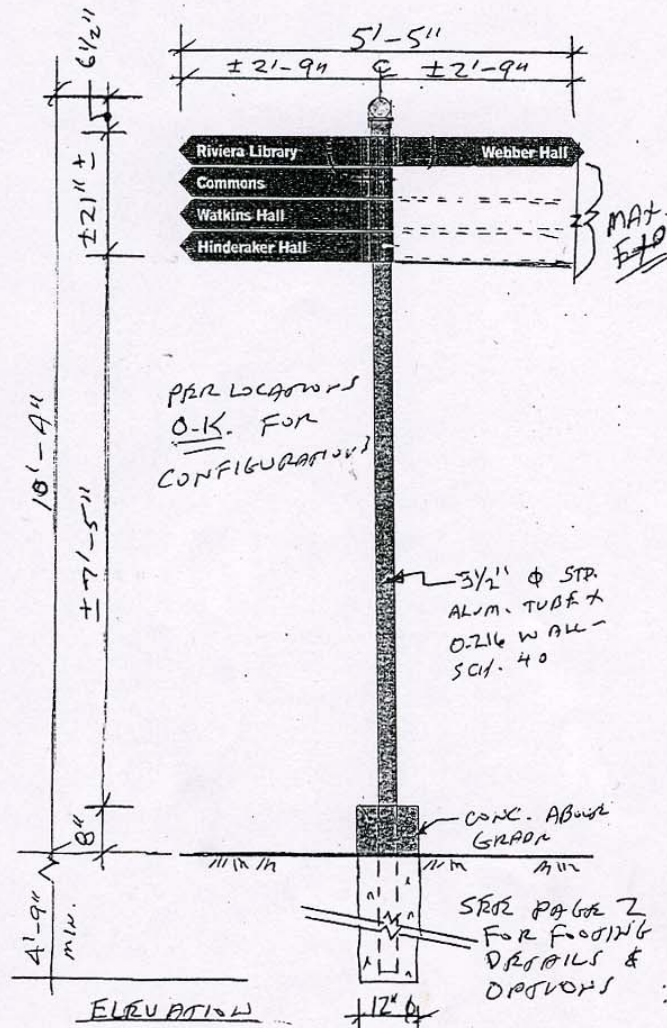

WIND CBC-'01 80 MPH EXP. C

CBC-1613	$p=Cq*Ce*Qs*I$	$I=1.0$	
$Qs =$	$16.4 Cq =$	1.4	
	$25.94 \text{ LBS/S.F. @ } 20'$	$Ce = 1.13$	
	$24.34 \text{ LBS/S.F. } < 15'$	$Ce = 1.06$	
S.F.	LBS	FT.	
AREA	!PRESS!	X-DIST	MOM-XX

	9.8	239	9.00	2147
	2.0	49	4.00	195
	0.7	17	0.34	6
	0.0	0	0.00	0

TOTAL 304 7.72 2347 (AVE.)

SINGLE COLUMN MOM. 'K 2.35

ALUM $F_y = 12 \text{ K/SQ. IN.}$
 $S = M/P_b$ WIND 1/3 INCR.
 $S = 0.75 * M$ (INCL 1.33 WIND)
 $S = 1.76 \text{ IN}^3$

$t = 0.216 \text{ IN. (MIN. THK.)}$
 $S = .0982 * (d^4 - d_1^4) / d$
 $d = 4$ $d_1 = 3.568$

USE MIN. 3.5" DIA. x 0.216 ALUM. PIPE

$S = 2.31 \text{ IN}^3 > 1.76$
O.K.

WT. OF SIGN = 130 LBS +/-
AXIAL STRESS IS NEGLIGIBLE

COAT ALUM. SURFACES EMBEDDED IN
CONC. WITH ONE HEAVY COAT OF
ALKALI-RESISTANT BITUMINOUS
(BITUMASTIC PAINT -- SUCH AS
HENRY'S OR EQUIVALENT).

SEE PAGE 2 FOR FOOTING DETAILS



SOB No. HUNT-1A7

HUNT DESIGN
25 N. MENTOR AVE.
PASADENA, CA 91106

PAGE: 2 of 2
PROJECT: UC RIVERSIDE
SUBJECT: RIVERSIDE, CA
SIGN STRUCTURAL CALCS.
BY: DVM DATE: 10-1-07
P.O.# DWGS. FROM PERRY SHIMOJI

SINGLE COLUMN
DESIGN OF EMBEDDED POLE FOOTINGS

DESCRIPTION	10" DIA.	12" DIA.	
CHOOSE ONE	OPTIONAL	OPTIONAL	
ALLOW PASSIVE	200	200	200
MAX PASSIVE	1,500	1,500	1,500
LOAD DURATION FACTOR	1.33	1.33	1.33
POINT LOAD	304	304	304
LOAD HT.	7.72	7.72	7.72
DIST. LOAD	0	0	0
START HT.	0.00	0.00	0.00
END HT.	0.00	0.00	0.00
WIDTH/DIAMETER	10"	12"	0
CIRCULAR ?	Y	Y	Y
RESTRAINED ?	N	N	N
SUMMARY			
Moments @ Surface:			
Point Load	2,347	2,347	0
Uniform Load	0	0	0
... Total Moment	2,347	2,347	0
Total Lateral Load	304	304	0
NON-RESTRAINED			
Min. Req'd Embedment	5'-2"	4'-9"	RESULTS
$A(1+(1+4.36h/A)^.5)/2$	5.06'	4.72'	0.00
$A=2.34P/(S 1 b)$			
Press @ 1/3 Embed.:			
Actual	449	419	0
Allowable	449	419	0
RESTRAINED			
Min. Req'd Embedment	0.00	0.00	0.00
$(4.25 P h / S 3 b)^.5$			
Pressure @ Bottom			
Actual	0	0	0
Allowable	0	0	0
Surface Restraint			
Force	0	0	0

PER CBC TABLE 18-1-
POLE 2x ALLOWABLE

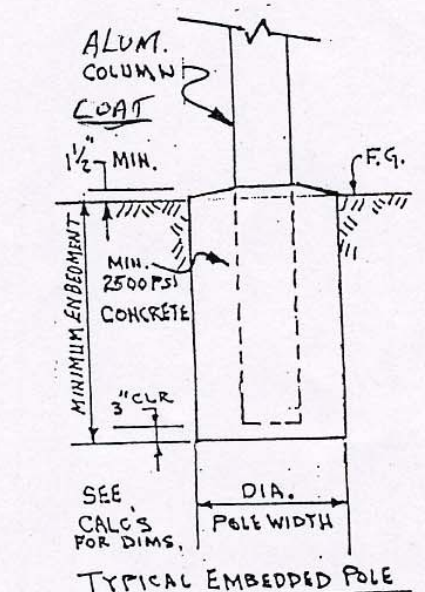

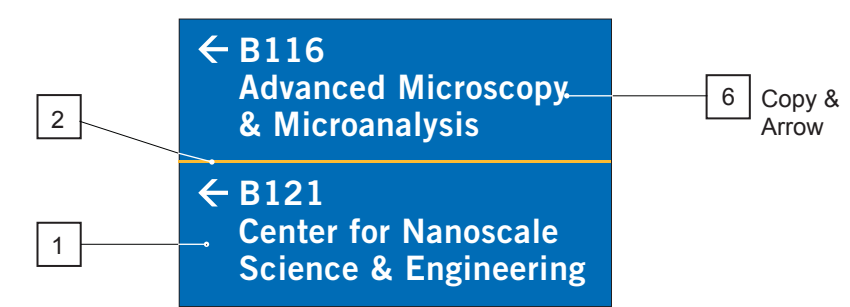
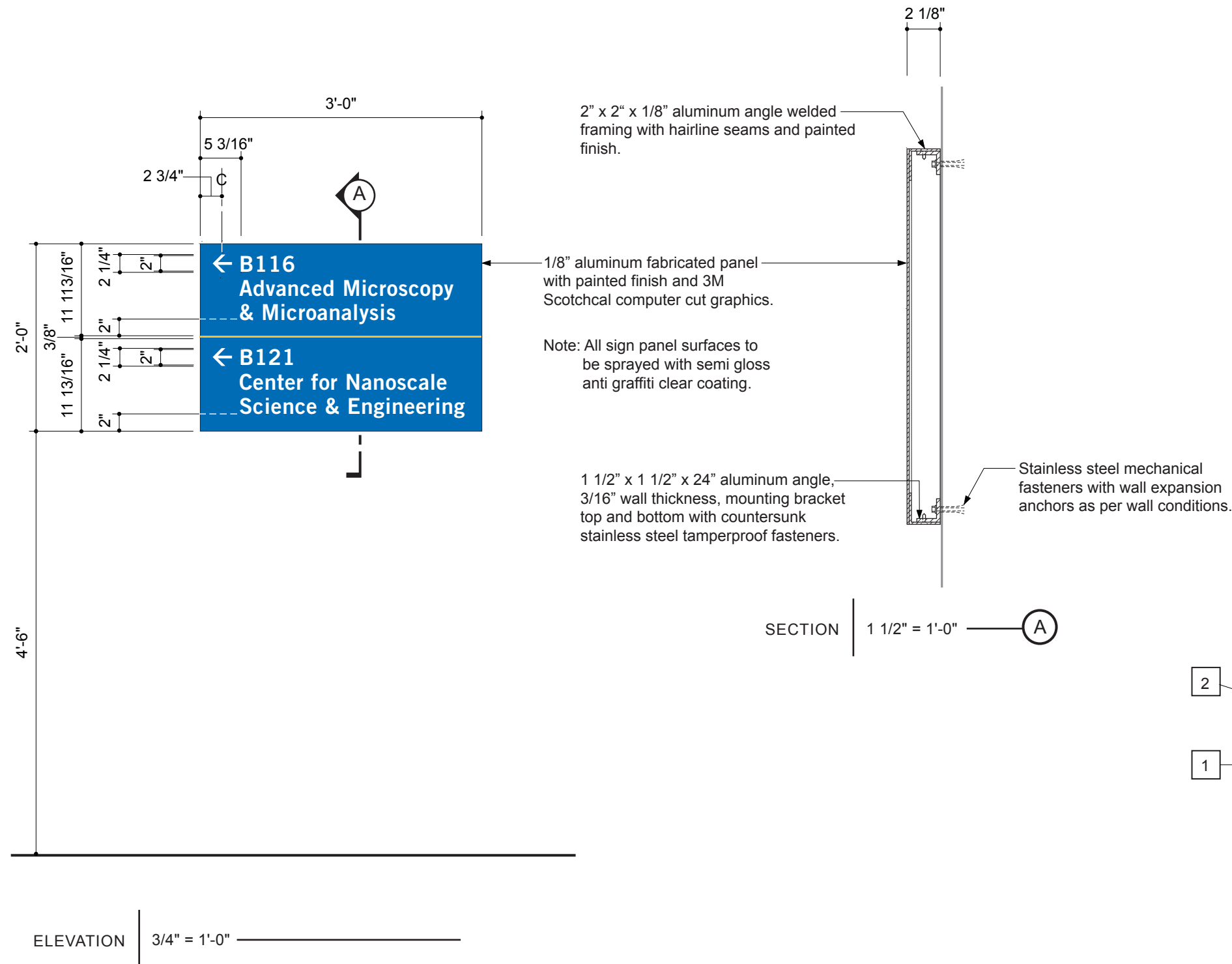

Note: All sign surfaces to be sprayed with semi gloss anti graffiti clear coating.

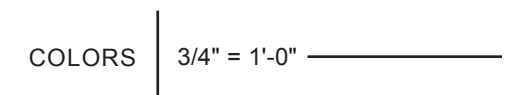



ELEVATION | 1" = 1'-0" ——— "ARROW" CONFIGURATIONS

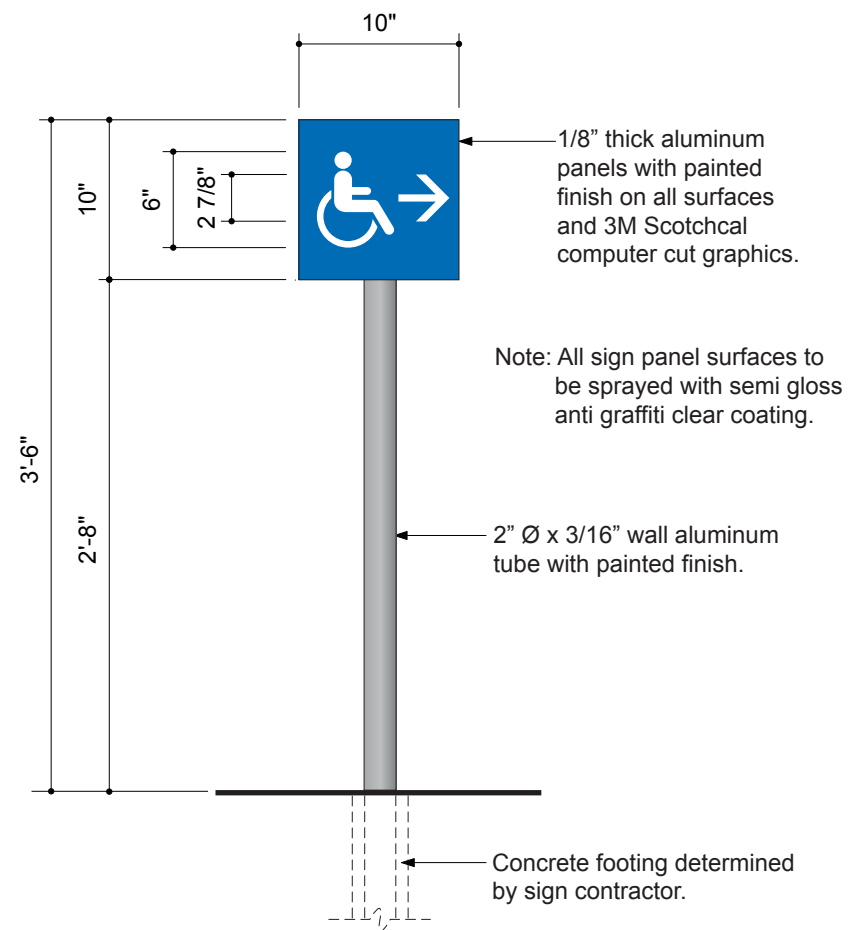

ELEVATION | 1" = 1'-0" ——— LAYOUT OPTION "A"

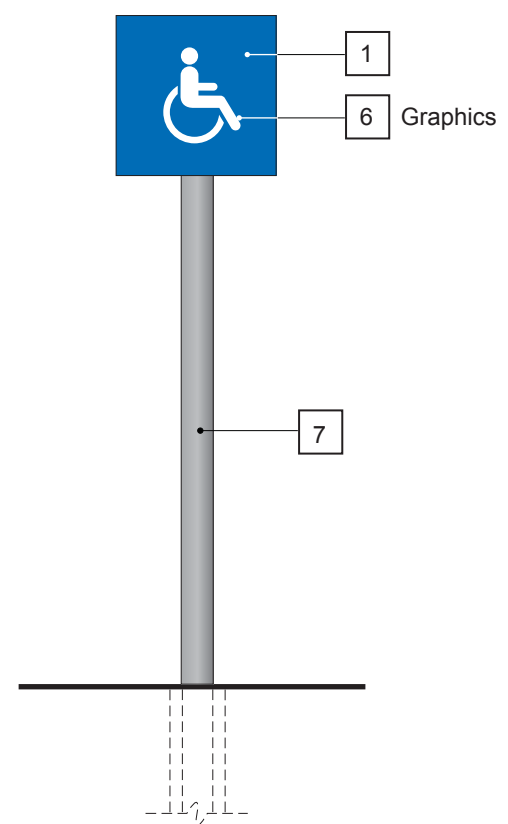

ELEVATION | 1" = 1'-0" ——— LAYOUT OPTION "B"

Note:
This sign cannot be used within any path of travel.
The height from the ground to the bottom of the sign is less than the minimum 80 inches ADA requirement for signs located in a path of travel.

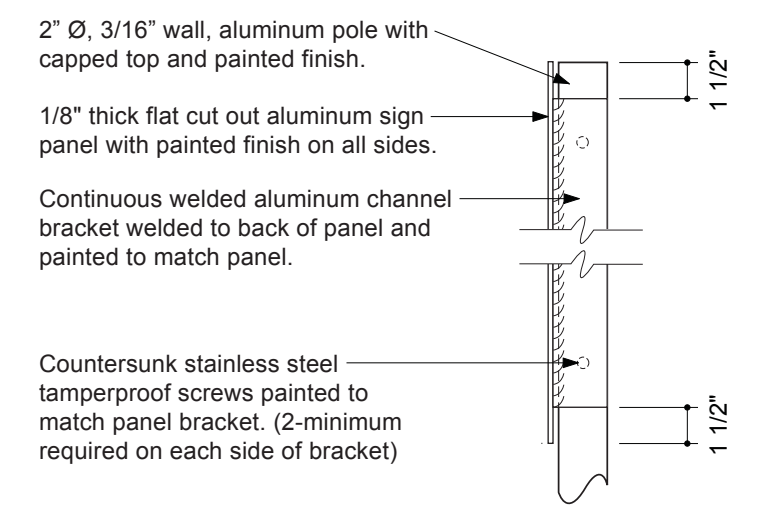
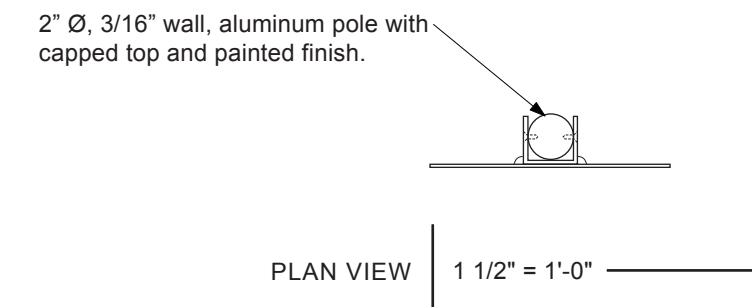

SIDE VIEW | 1 1/2" = 1'-0"

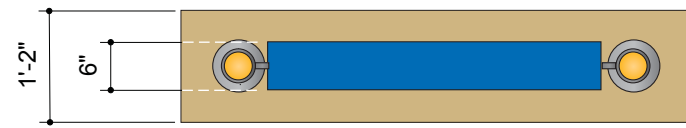

PLAN VIEW 1/2" = 1'-0"

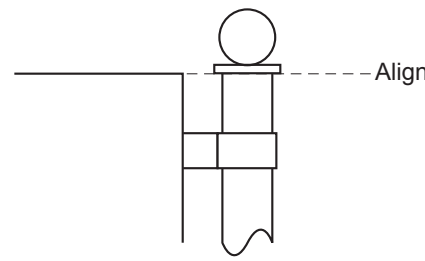

FINIAL DETAIL 1" = 1'-0"

Exterior grade transparent colored digital print with U.V. inhibitors for exterior use and adhesive backing applied to #7238 white acrylic panel.

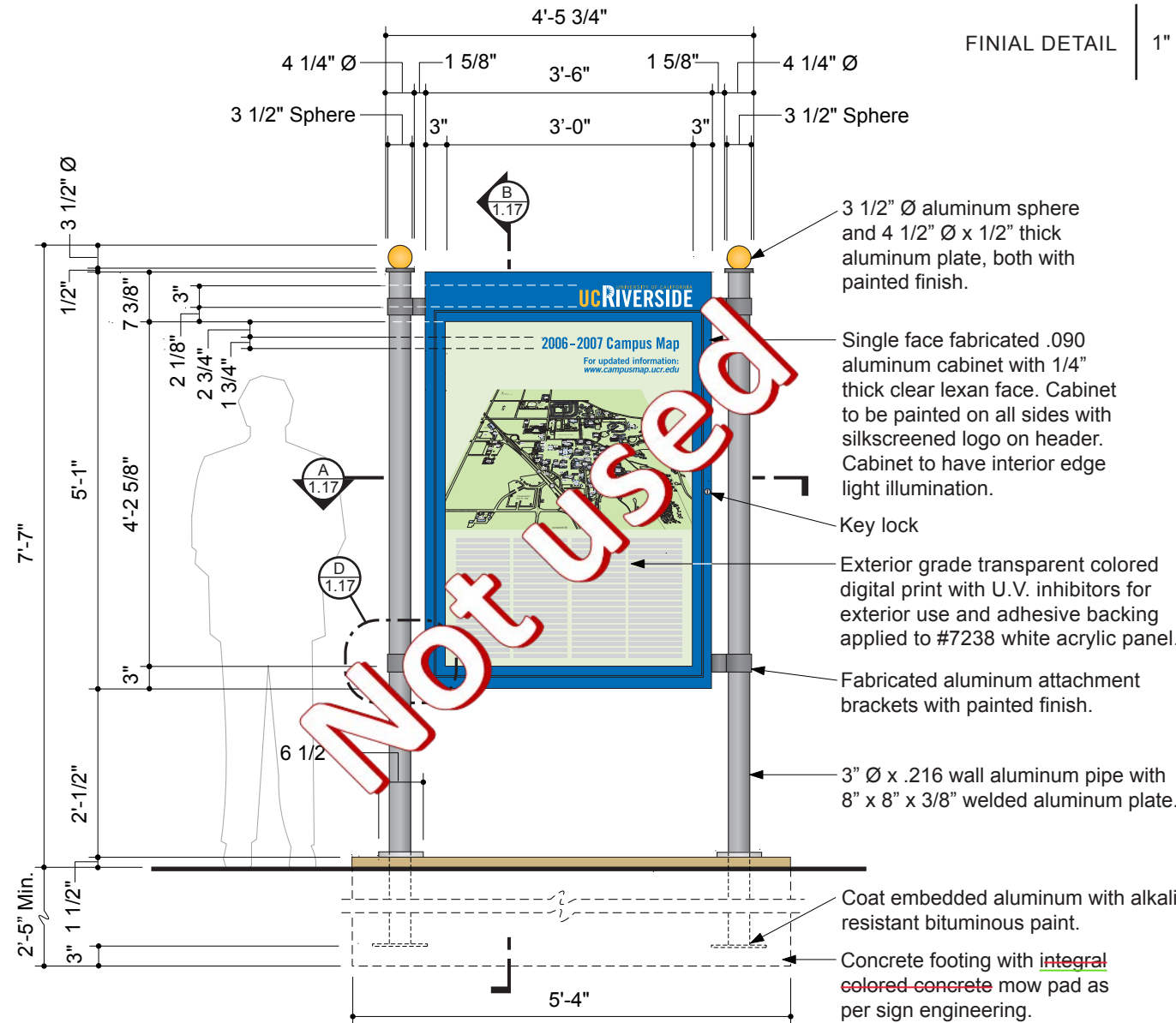

ELEVATION 1/2" = 1'-0"

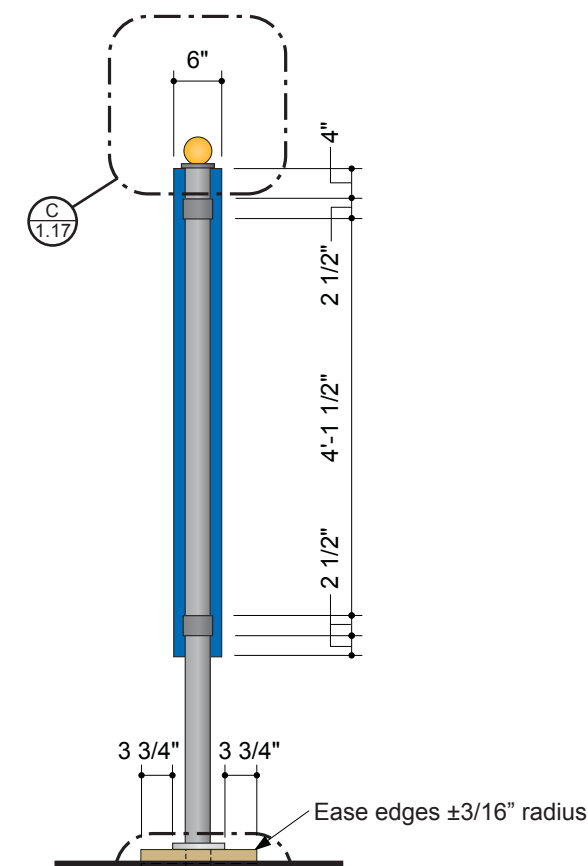

SIDE VIEW 1/2" = 1'-0"

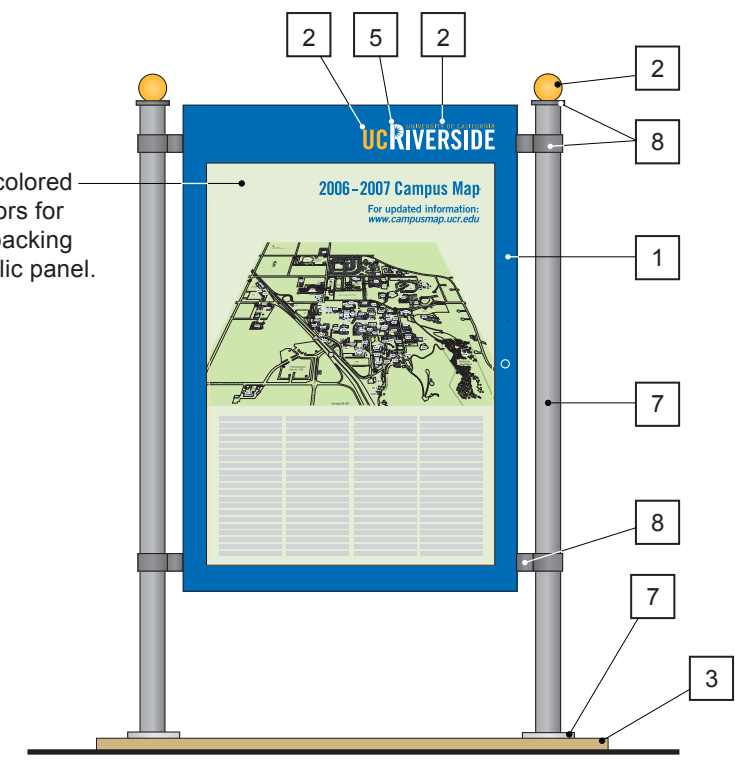

COLORS | N.T.S.



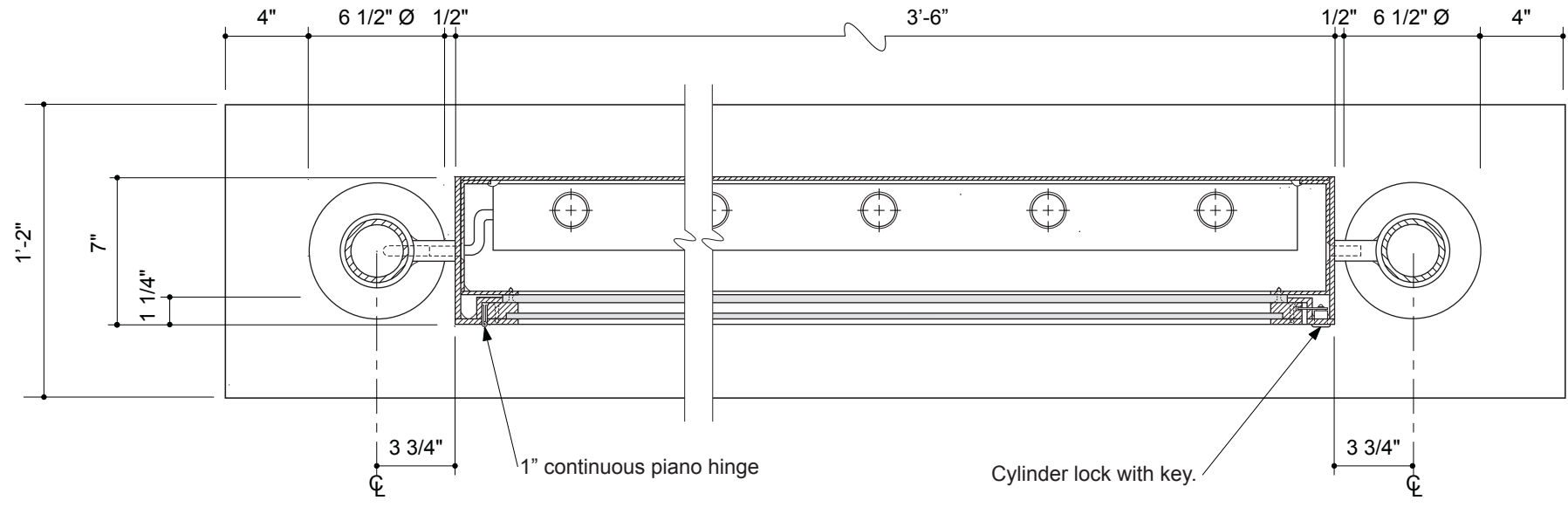

SECTION | 1 1/2" = 1'-0" — (A)

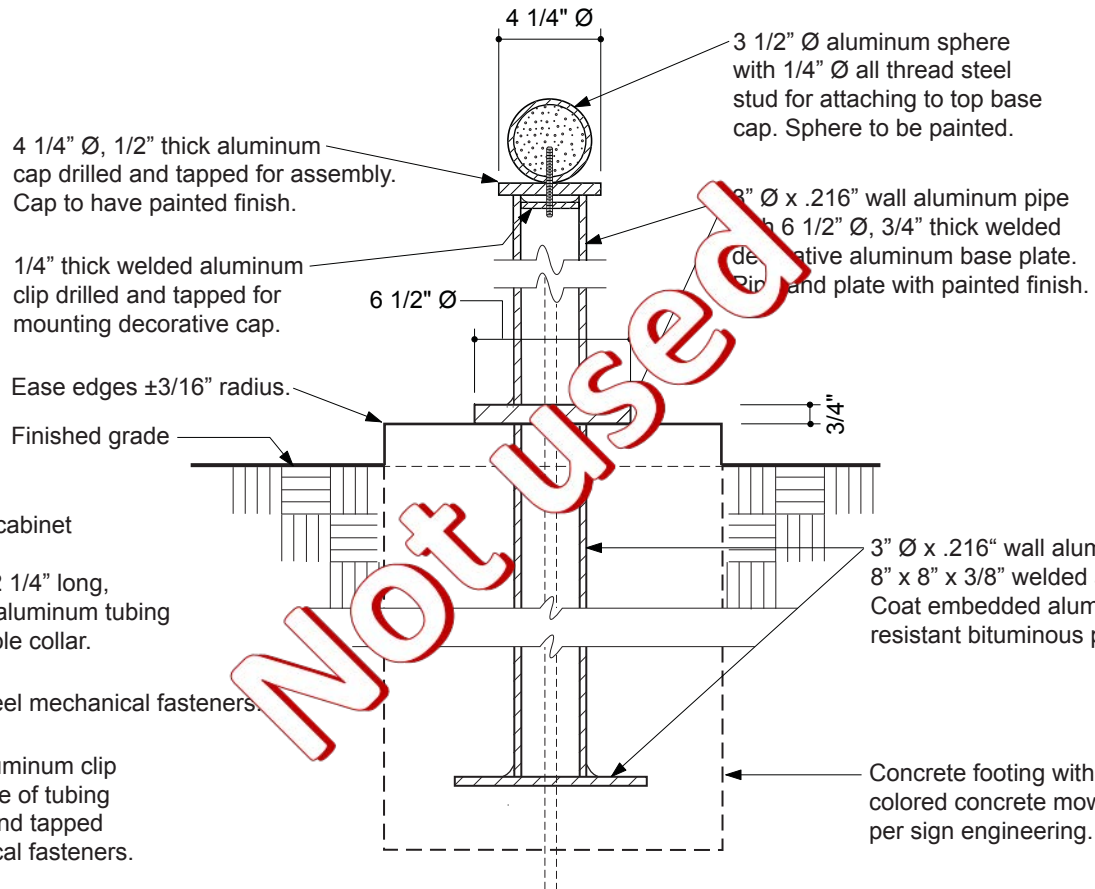

Not Used

SECTION | 1 1/2" = 1'-0" — (C)

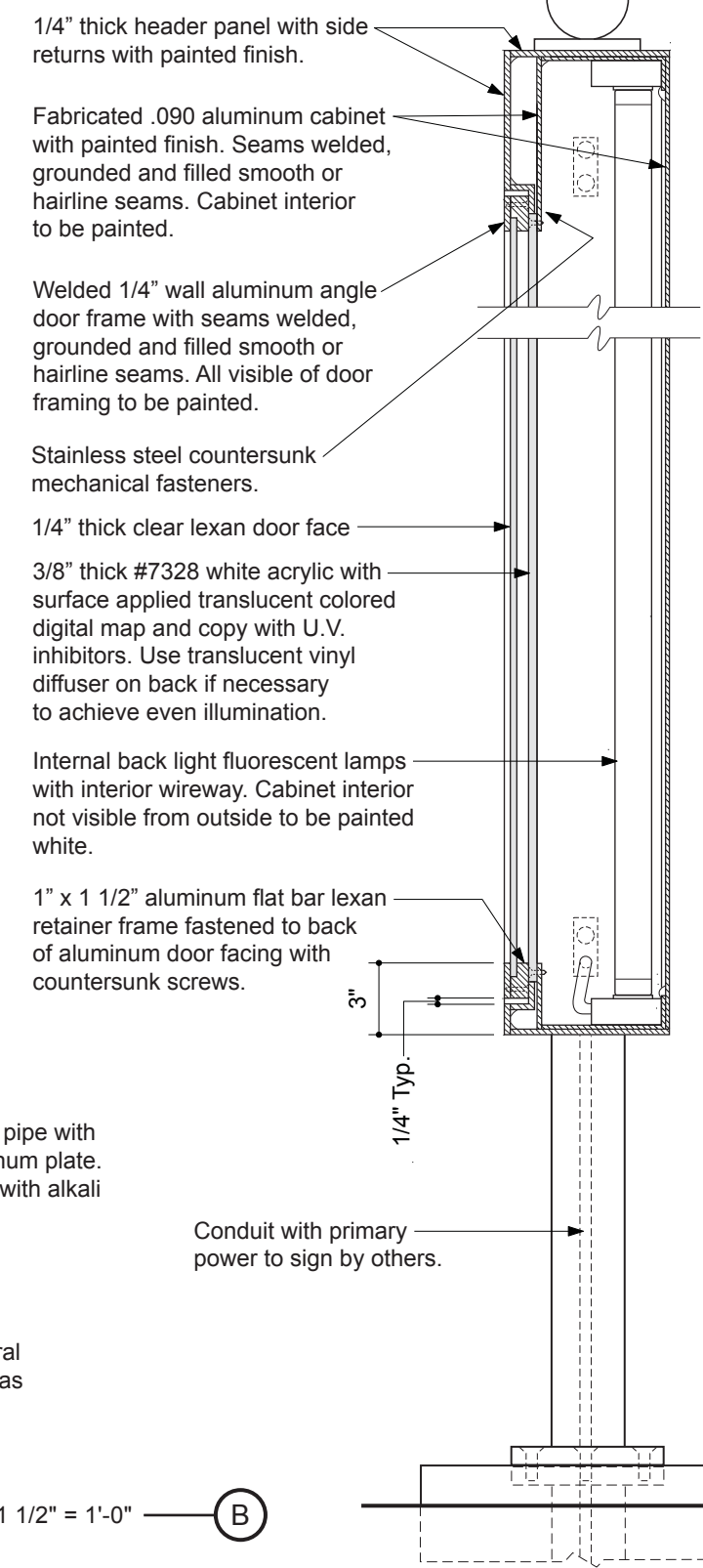

SECTION | 1 1/2" = 1'-0" — (B)

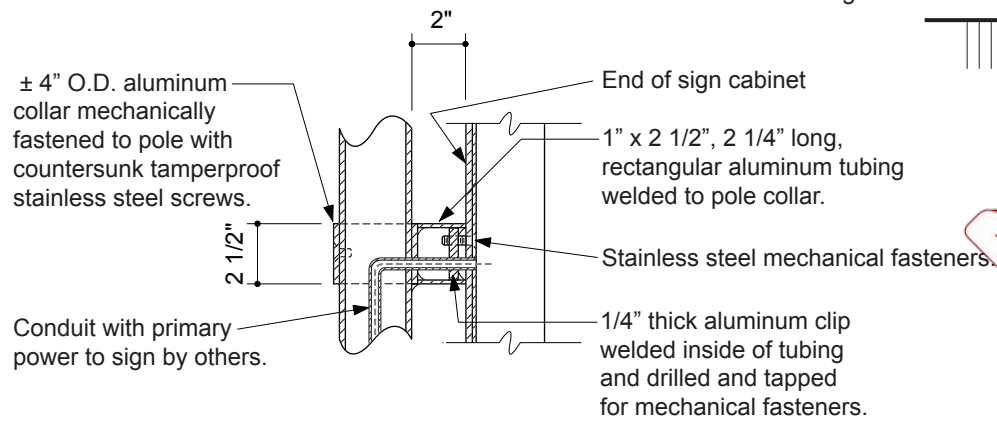

SECTION | 1 1/2" = 1'-0" — (D)

COAST SIGN, INC.
1345 S. ALLEC STREET
ANAHEIM, CA 92805

PAGE: 1 of 2
PROJECT: UC RIVERSIDE
SUBJECT: RIVERSIDE, CA
SIGN STRUCTURAL CALCS.
BY: DVM DATE: 10-3-07
P.O.# DWGS. FROM PERRY SHIMOJI

FOR COLUMN & FOOTING DESIGN

AREA -- SIGN TYPE W40.0 & W42.0
A = 3.5' * 5.25' = 18.4 S.F.
A = 6.88' * 0.25' * 2 COL. = 3.4 S.F.

NOTE: SIGN TYPE W42.0 IS SLIGHTLY
SMALLER IN SIZE THAN W40.0 -
COLUMN & FOOTING DESIGN FOR BOTH
IS O.K. BY INSPECTION

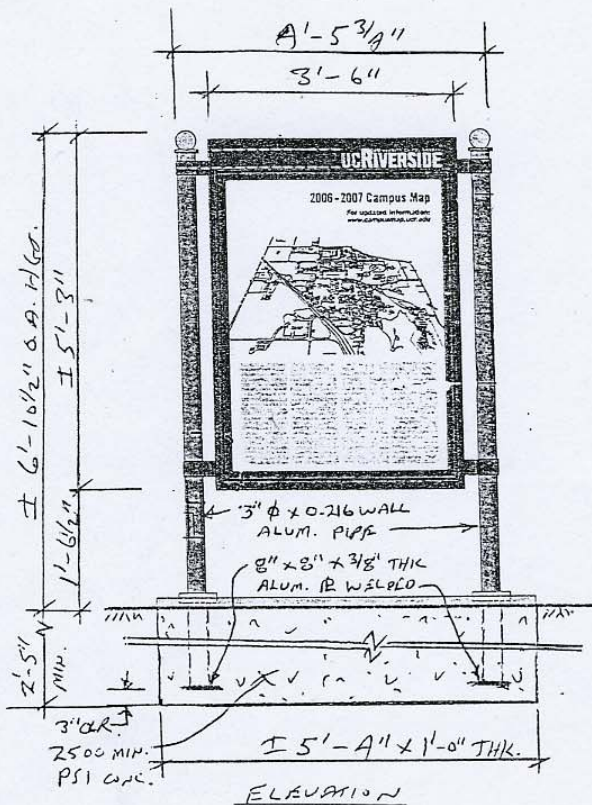

WIND	CBC-'01	80 MPH, EXP. C
CBC-1613	$p=Cq*Ce*Qs*I$	$I=1.0$
Qs =	16.4	Cq = 1.4
	25.94 LBS/S.F. @ 20'	Ce = 1.13
	24.34 LBS/S.F. < 15'	Ce = 1.06
S.F.	LBS	FT. FT. LBS
AREA	!PRESS!	X-DIST ! MOM-XX
18.4	448	4.26 1908
3.4	83	3.44 285
0.0	0	0.00 0
0.0	0	0.00 0

TOTAL	531	4.13	2192
		(AVE.)	
<u>DOUBLE COLUMN</u>			
	MOM. 'K	1.10	

ALUM $F_y = 12$ K/SQ. IN.
 $S = M/Fb$ WIND 1/3 INCR.
 $S = 0.75 * M$ (INCL 1.33 WIND)
 $S = 0.82$ IN³
 $t = 0.216$ IN. (MIN. THK.)
 $S = .0982*(d^4-d1^4)/d$
 $d = 3.5$ $d1 = 3.068$
USE MIN. 3" DIA. x 0.216 ALUM. PIPE #40
 $S = 1.72$ IN³ > 0.82
O.K.

WT. OF SIGN = 220 LBS +/-
AXIAL STRESS IS NEGLIGIBLE

COAT ALUM. SURFACES EMBEDDED IN
CONC. WITH ONE HEAVY COAT OF
ALKALI-RESISTANT BITUMINOUS
(BITUMASTIC PAINT -- SUCH AS
HENRY'S OR EQUIVALENT).

SEE PAGE 2 FOR FOOTING DETAILS



JOB NO. HUNT-146

HUNT DESIGN
25 N. MENTOR AVE.
PASADENA, CA 91106

PAGE: 2 of 2
PROJECT: UC RIVERSIDE
SUBJECT: RIVERSIDE, CA
SIGN STRUCTURAL CALCS.
BY: DVM DATE: 10-1-07
P.O.# DWGS. FROM PERRY SHIMOJI

SINGLE FOOTING - STRAIGHT
DESIGN OF EMBEDDED POLE FOOTINGS

DESCRIPTION	>>	64" WIDE		
	>>	X 12" THK.		
ALLOW PASSIVE	psf	200	200	200
MAX PASSIVE	psf	1,500	1,500	1,500
LOAD DURATION FACTOR		1.33	1.33	1.33
POINT LOAD	lbs	31	0	0
LOAD HT.	ft	4	0.00	0.00
DIST. LOAD	#/ft		0	0
START HT.	ft	00	0.00	0.00
END HT.	ft		0.00	0.00
WIDTH/DIAMETER	in	64"	0	0
CIRCULAR ?	N		N	N
RESTRAINED ?	y/n	N	N	N
<u>SUMMARY</u>				
Moments @ Surf				
Point Load	ft-#	2,193	0	0
Uniform Load	ft-#	0	0	0
... Total Point	ft-#	2,193	0	0
Total Lateral Load	#	531	0	0
<u>NON RESTRAINED</u>				
Req'd Embedment		2'-5"		
$A(1+(1+4.36h/A)^.5)/2$				
$A=2.34P/(S 1 b)$	ft	2.34'	0.00	0.00
Press @ 1/3 Embed.:		MIN.		
Actual	psf	207	0	0
Allowable	psf	207	0	0
<u>RESTRAINED</u>				
Min. Req'd Embedment				
$(4.25 P h/S3 b)^.5$	ft	0.00	0.00	0.00
Pressure @ Bottom				
Actual	psf	0	0	0
Allowable	psf	0	0	0
Surface Restraint				
Force	lbs	0	0	0

PER CBC TABLE 18-1-A
POLE 2x ALLOWABLE



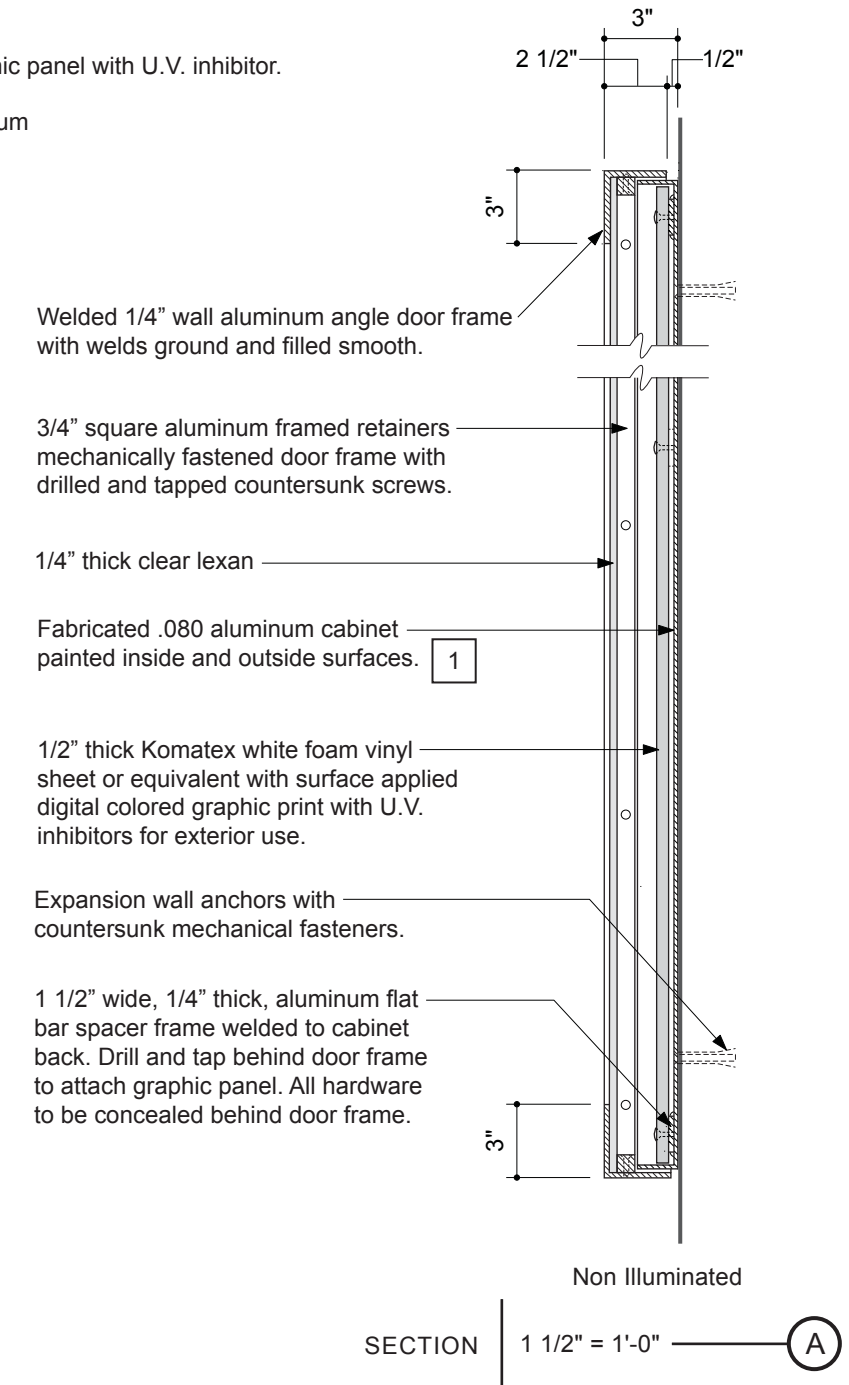
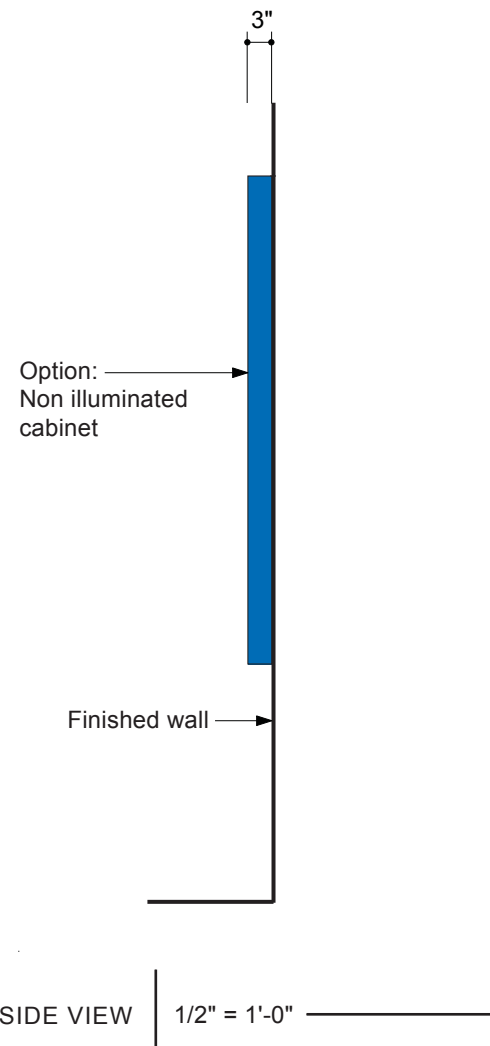
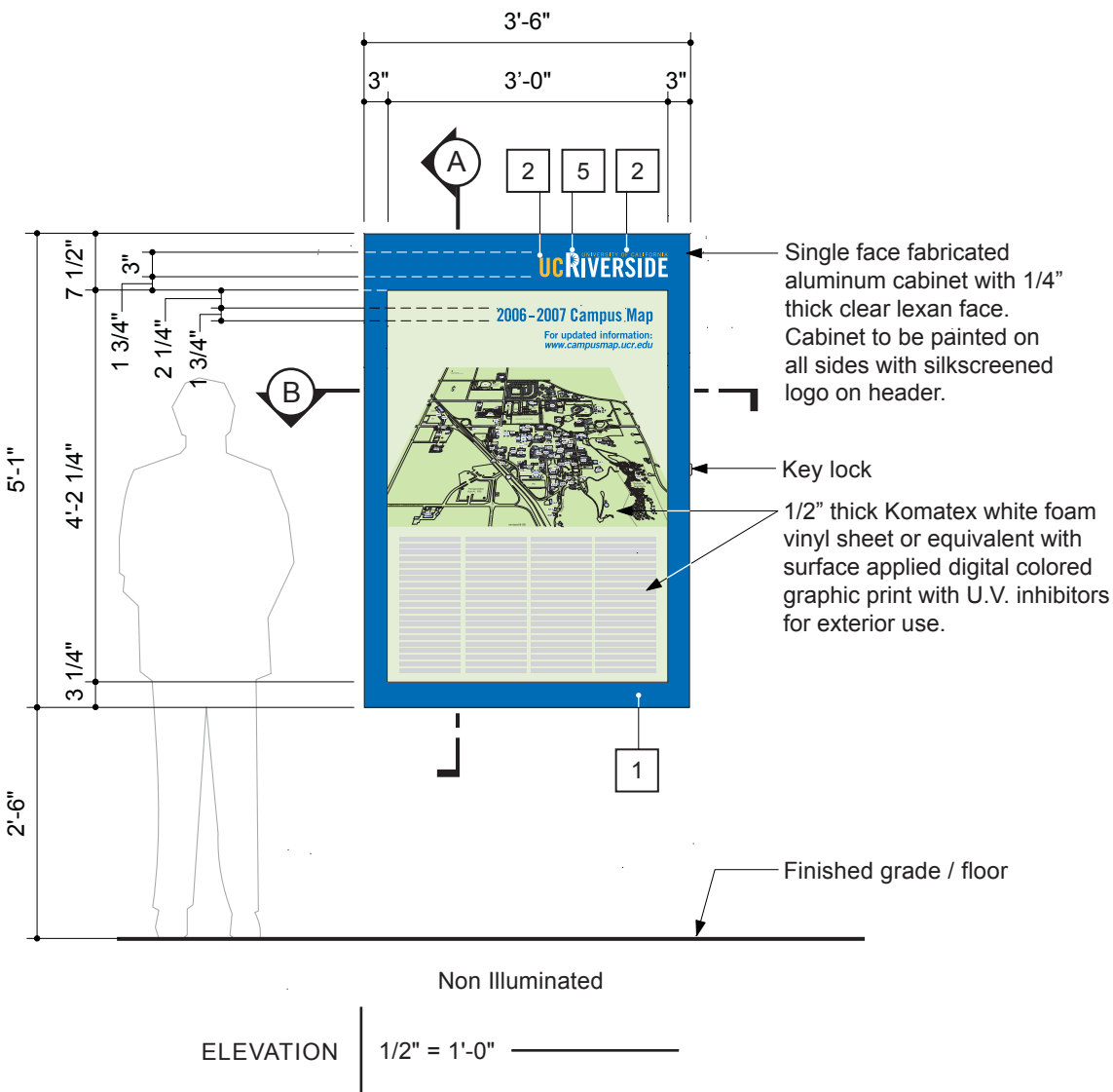
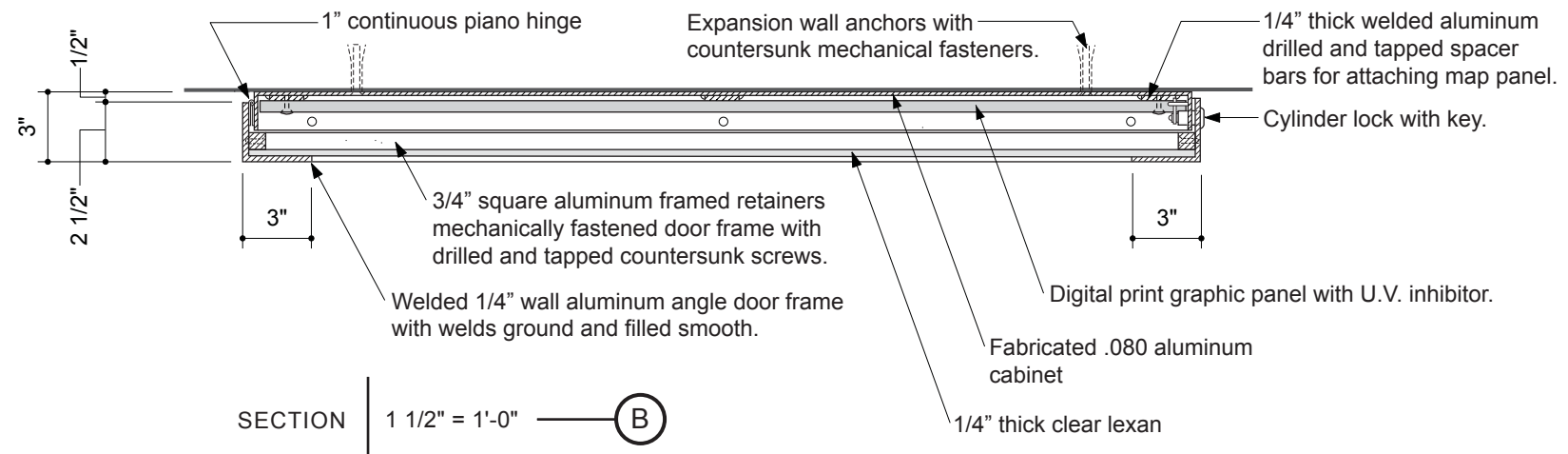

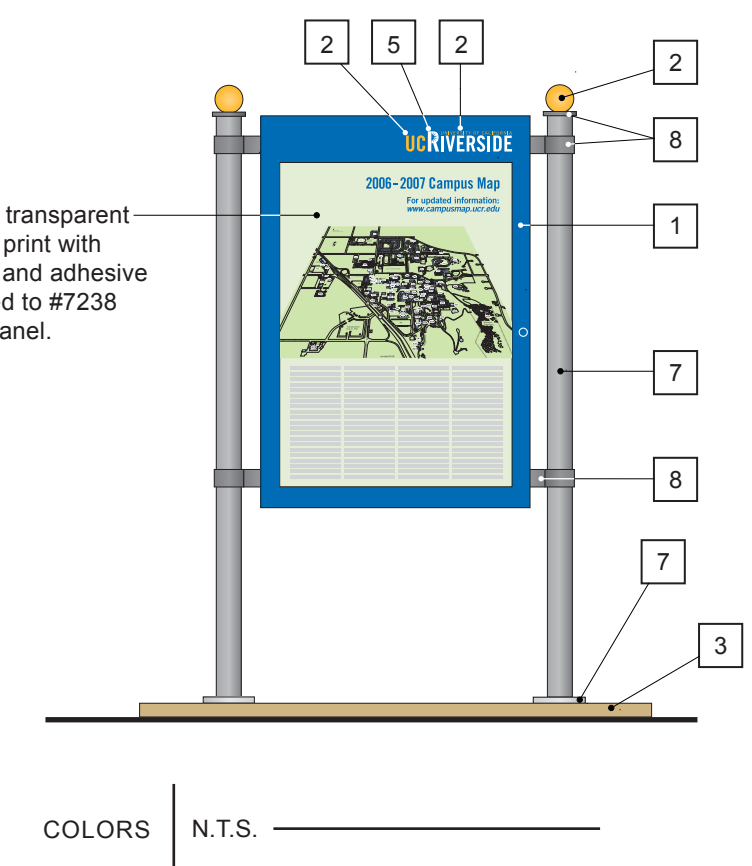
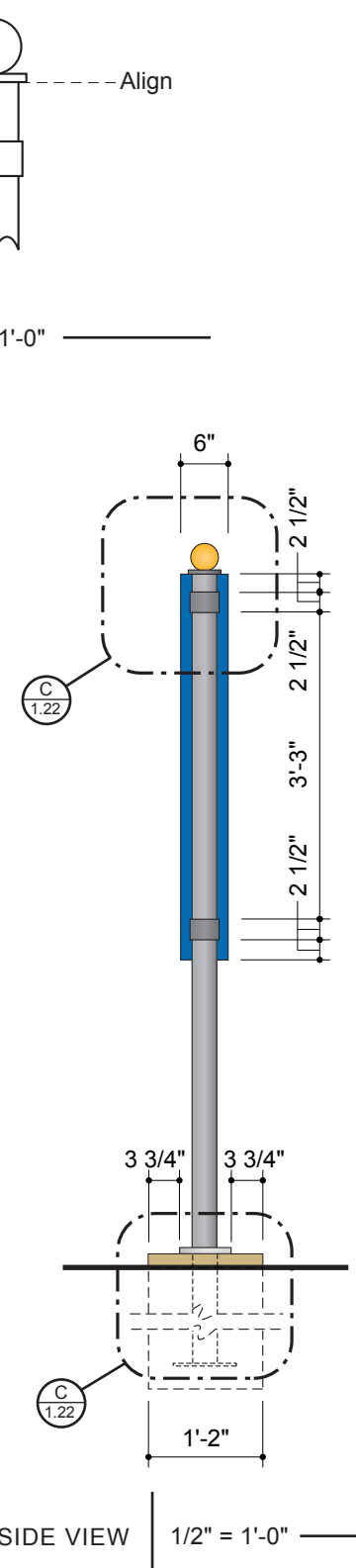
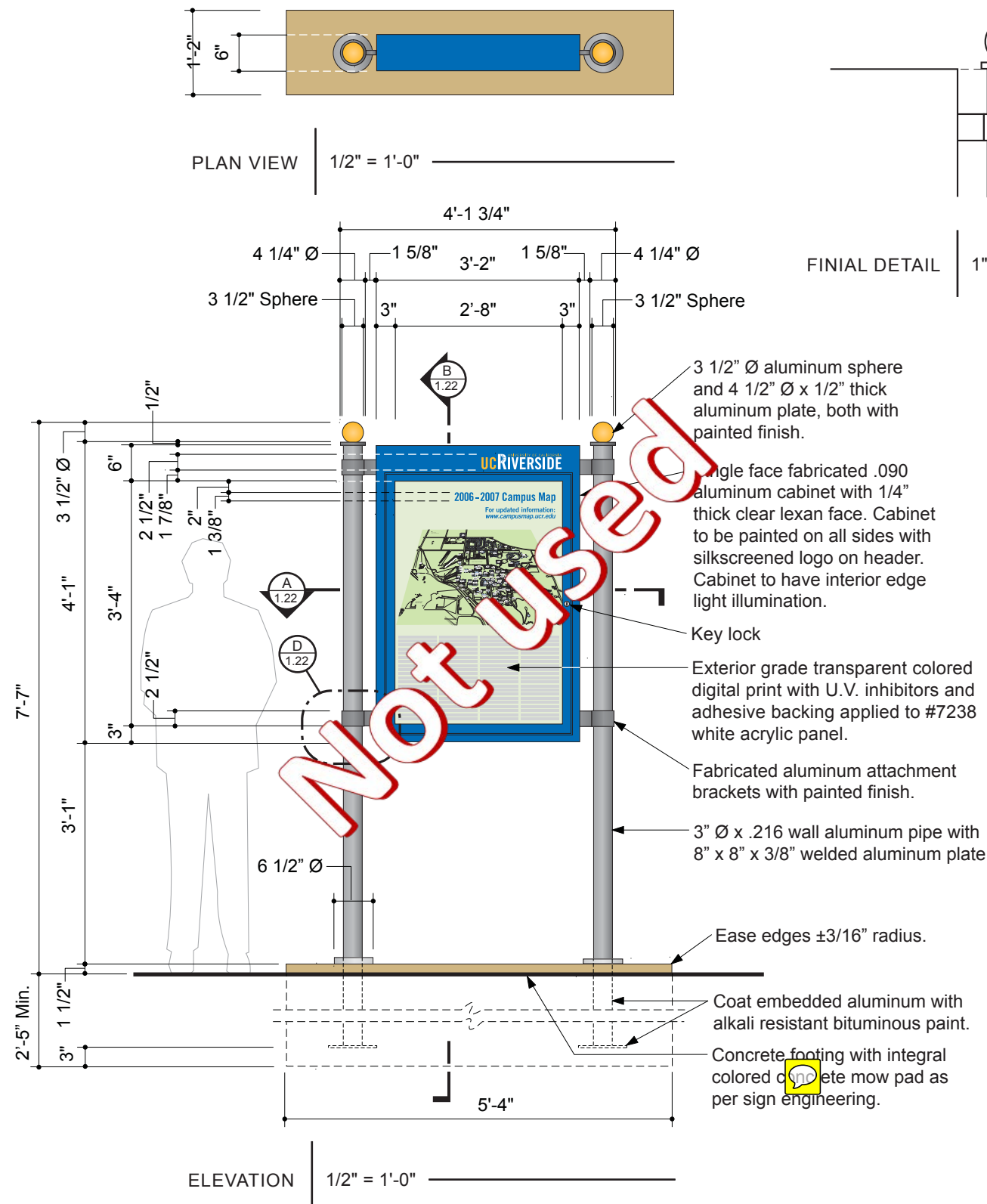

Not used

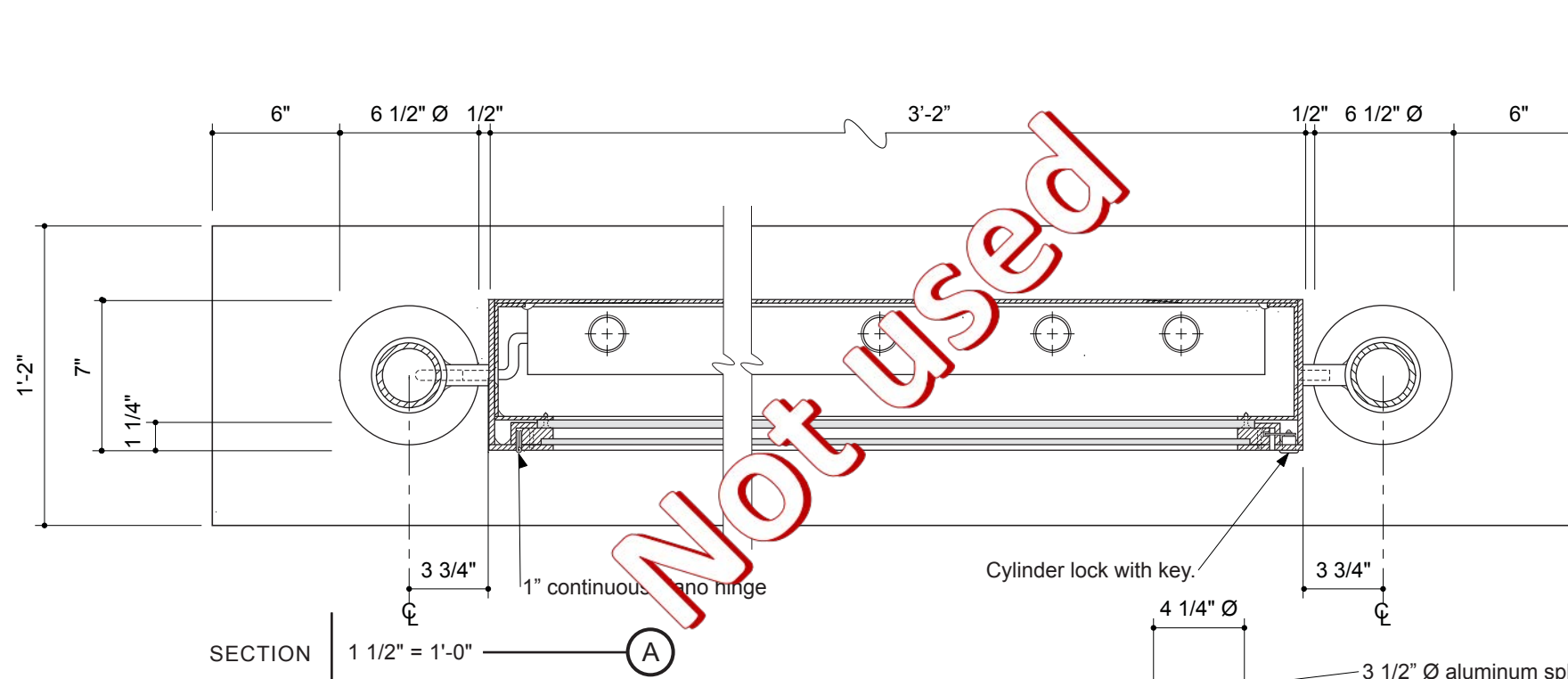

Not used

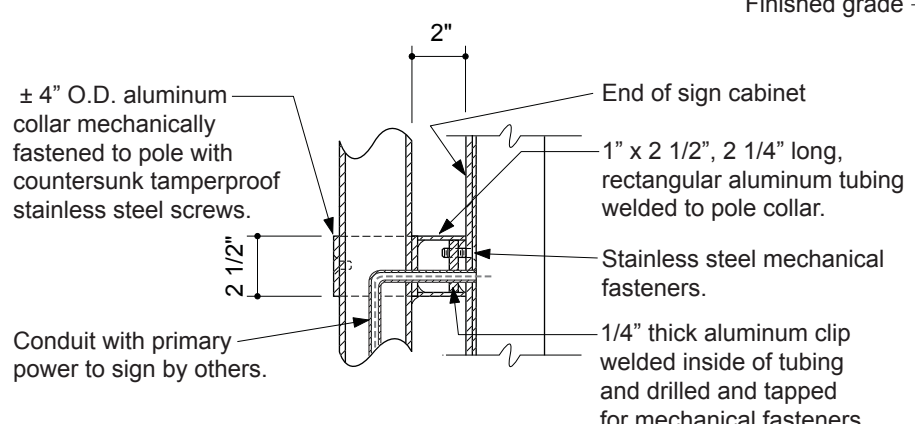
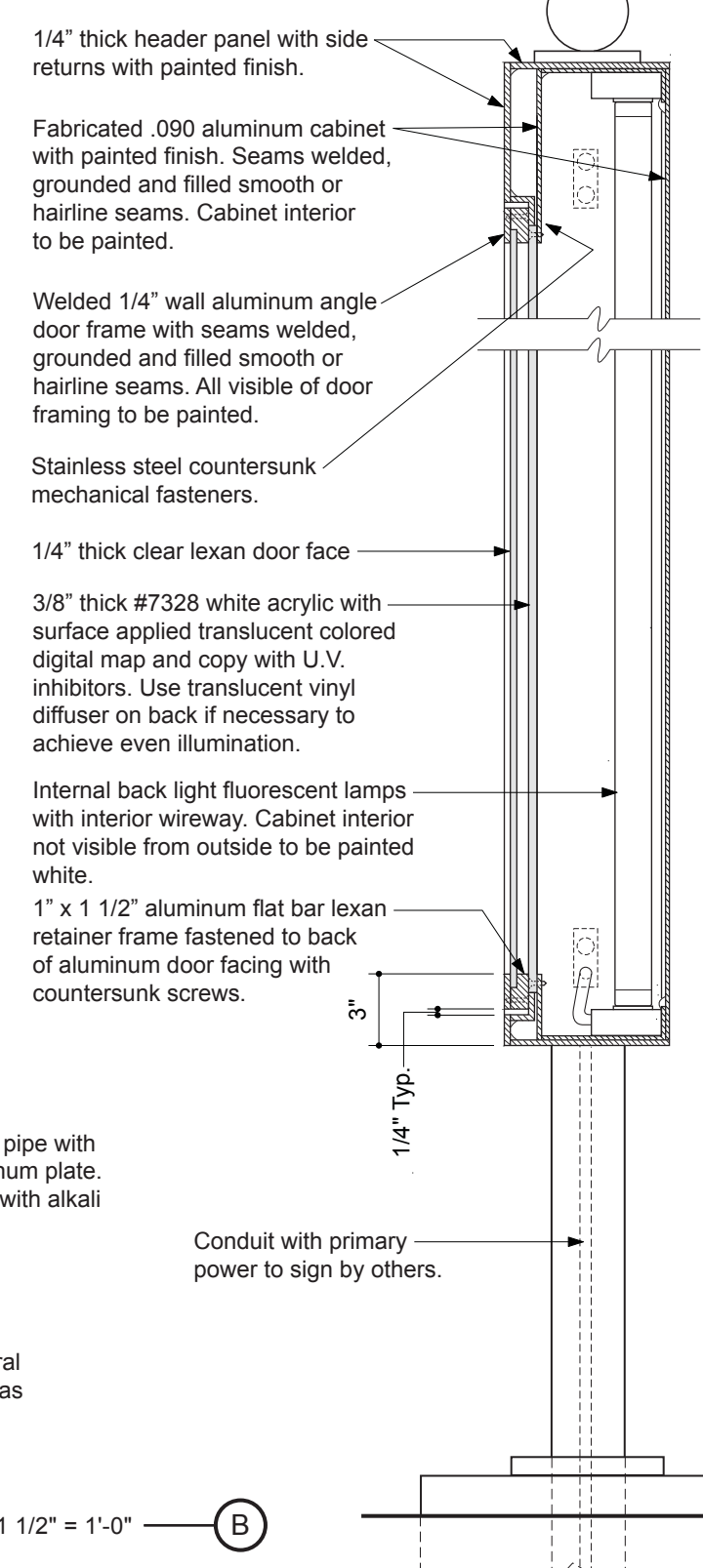
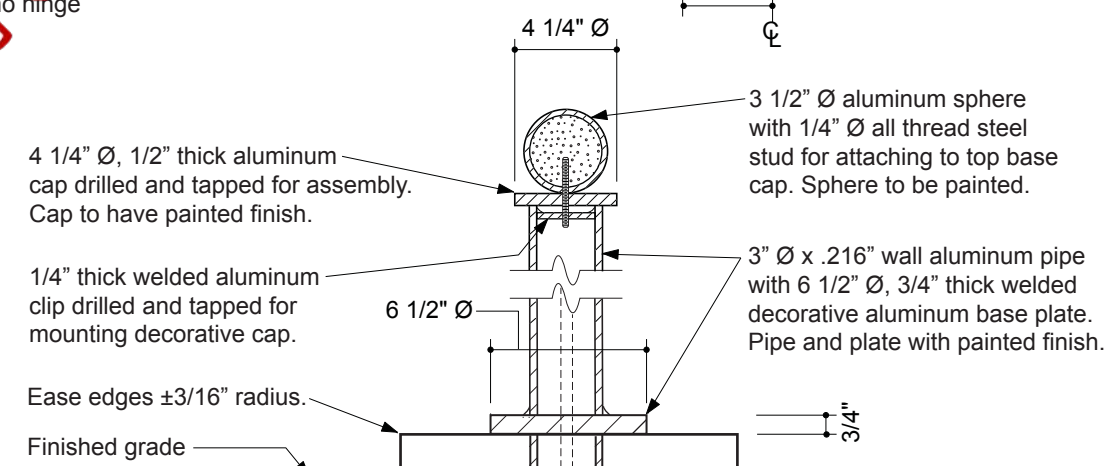

SECTION | 1 1/2" = 1'-0" — (D)

SECTION | 1 1/2" = 1'-0" — (C)

SECTION | 1 1/2" = 1'-0" — (B)

COAST SIGN, INC.
1345 S. ALLEC STREET
ANAHEIM, CA 92805

PAGE: 1 of 2
PROJECT: UC RIVERSIDE
SUBJECT: RIVERSIDE, CA
SIGN STRUCTURAL CALCS.
BY: DVM DATE: 10-3-07
P.O.# DWGS. FROM PERRY SHIMOJI

FOR COLUMN & FOOTING DESIGN

AREA -- SIGN TYPE W40.0 & W42.0
A = 3.5' * 5.25' = 18.4 S.F.
A = 6.88' * 0.25' * 2 COL. = 3.4 S.F.

NOTE: SIGN TYPE W42.0 IS SLIGHTLY
SMALLER IN SIZE THAN W40.0 -
COLUMN & FOOTING DESIGN FOR BOTH
IS O.K. BY INSPECTION

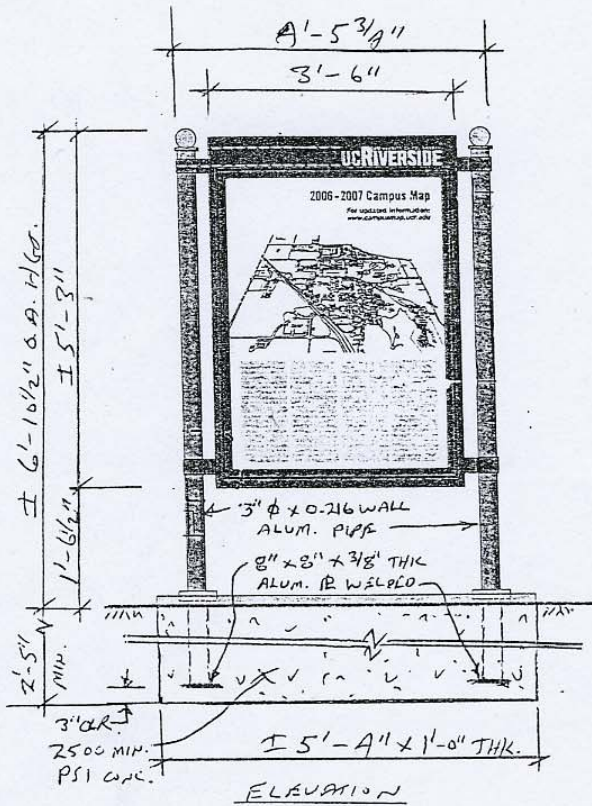

WIND	CBC-'01	80 MPH, EXP. C
CBC-1613	$p=Cq*Ce*Qs*I$	$I=1.0$
Qs =	16.4	Cq = 1.4
	25.94 LBS/S.F. @ 20'	Ce = 1.13
	24.34 LBS/S.F. < 15'	Ce = 1.06
S.F.	LBS	FT. FT. LBS
AREA	!PRESS!	X-DIST ! MOM-XX
18.4	448	4.26 1908
3.4	83	3.44 285
0.0	0	0.00 0
0.0	0	0.00 0

TOTAL	531	4.13	2192
		(AVE.)	
DOUBLE COLUMN			
MOM. 'K	1.10		

ALUM $F_y = 12 \text{ K/SQ. IN.}$
S = M/Fb WIND 1/3 INCR.
S = 0.75 * M (INCL 1.33 WIND)
S = 0.82 IN³
t = 0.216 IN. (MIN. THK.)
S = .0982*(d⁴-d1⁴)/d
d = 3.5 d1 = 3.068
USE MIN. 3" DIA. x 0.216 ALUM. PIPE #
S = 1.72 IN³ > 0.82

WT. OF SIGN = 220 LBS +/-
AXIAL STRESS IS NEGLIGIBLE

COAT ALUM. SURFACES EMBEDDED IN
CONC. WITH ONE HEAVY COAT OF
ALKALI-RESISTANT BITUMINOUS
(BITUMASTIC PAINT -- SUCH AS
HENRY'S OR EQUIVALENT).

SEE PAGE 2 FOR FOOTING DETAILS



JOB NO. HUNT-146

HUNT DESIGN
25 N. MENTOR AVE.
PASADENA, CA 91106

PAGE: 2 of 2
PROJECT: UC RIVERSIDE
SUBJECT: RIVERSIDE, CA
SIGN STRUCTURAL CALCS.
BY: DVM DATE: 10-1-07
P.O.# DWGS. FROM PERRY SHIMOJI

SINGLE FOOTING - STRAIGHT
DESIGN OF EMBEDDED POLE FOOTINGS

DESCRIPTION	>>	64" WIDE		
	>>	X 12" THK.		
ALLOW PASSIVE	psf	200	200	200
MAX PASSIVE	psf	1,500	1,500	1,500
LOAD DURATION FACTOR		1.33	1.33	1.33
POINT LOAD	lbs	531	0	0
LOAD HT.	ft	4.13	0.00	0.00
DIST. LOAD	#/ft	0	0	0
START HT	ft	0.00	0.00	0.00
END HT	ft	0.00	0.00	0.00
WIND METER	in	64"	0	0
REMAINED?	y/n	N	N	N
REMAINED?	y/n	N	N	N
--- SUMMARY ---				
Moments @ Surface:				
Point Load	ft-#	2,193	0	0
Uniform Load	ft-#	0	0	0
... Total Moment	ft-#	2,193	0	0
Total Lateral Load	#	531	0	0
--- NON-RESTRAINED ---				
Min. Req'd Embedment				
$A(1+(1+4.36h/A)^.5)/2$		2'-5"		
$A=2.34P/(S 1 b)$	ft	2.34'	0.00	0.00
Press @ 1/3 Embed.:				
Actual	psf	207	0	0
Allowable	psf	207	0	0
--- RESTRAINED ---				
Min. Req'd Embedment				
$(4.25 P h/S3 b)^.5$	ft	0.00	0.00	0.00
Pressure @ Bottom				
Actual	psf	0	0	0
Allowable	psf	0	0	0
Surface Restraint Force				
	lbs	0	0	0

PER CBC TABLE 18-1-A
POLE 2x ALLOWABLE



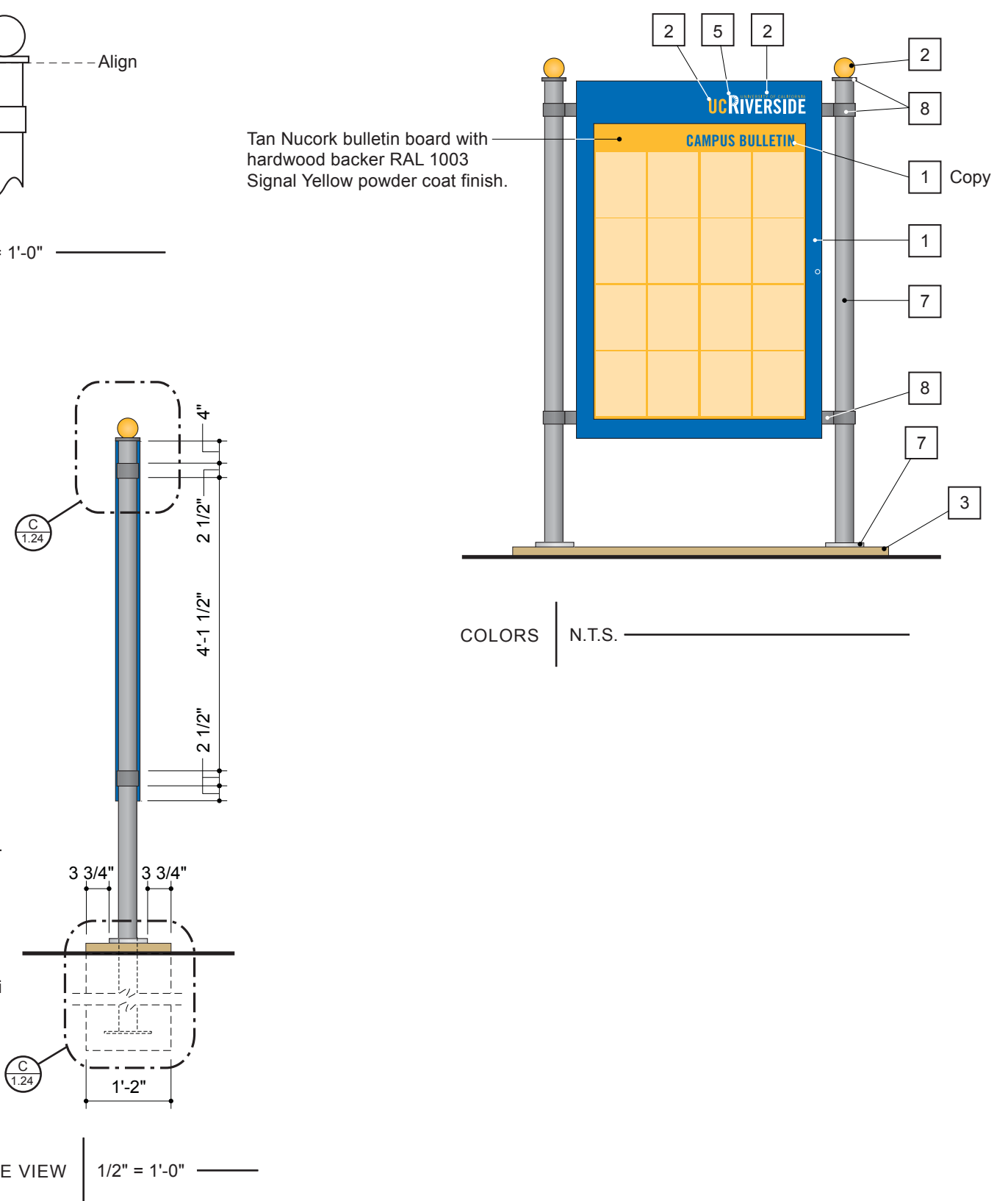
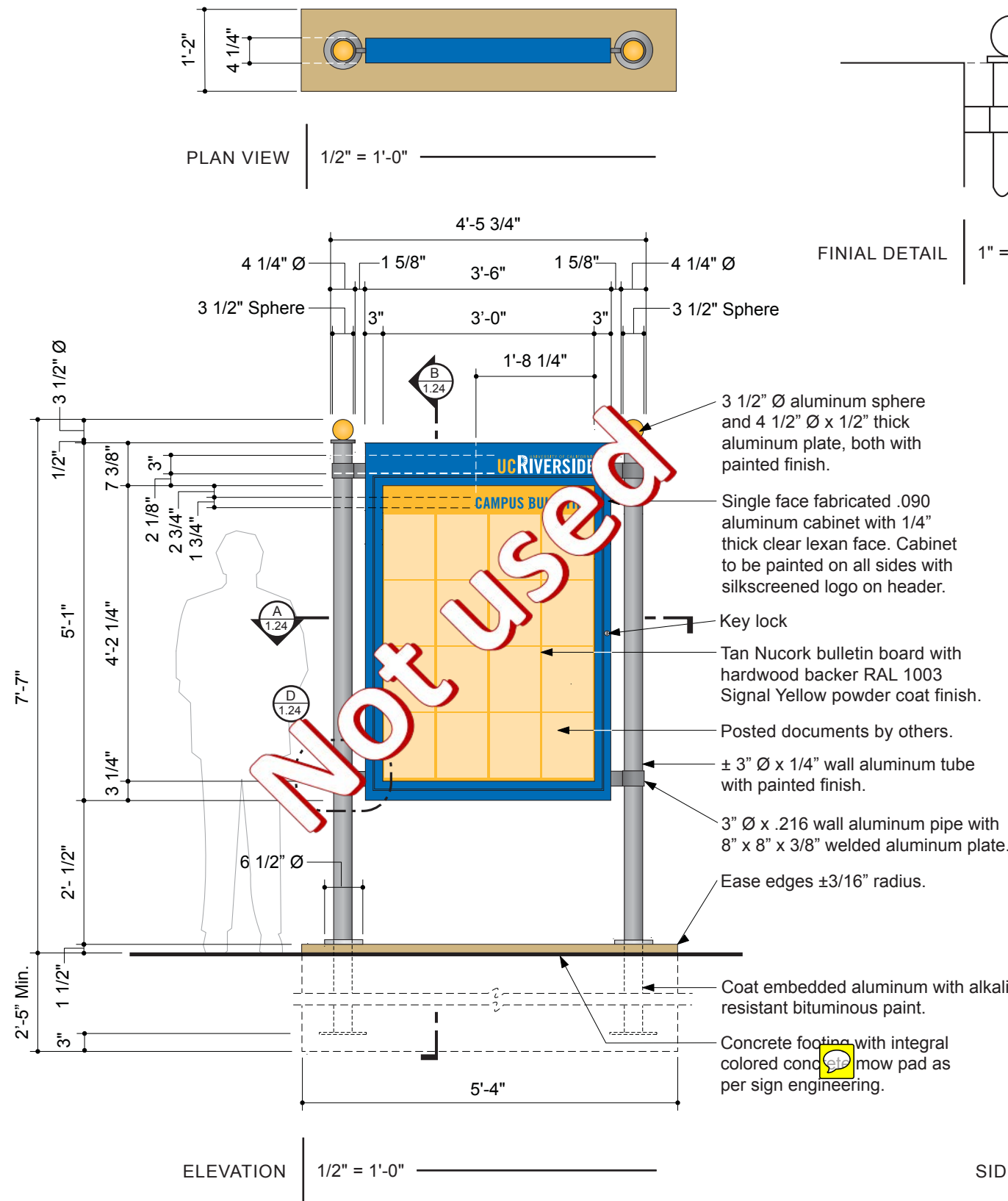

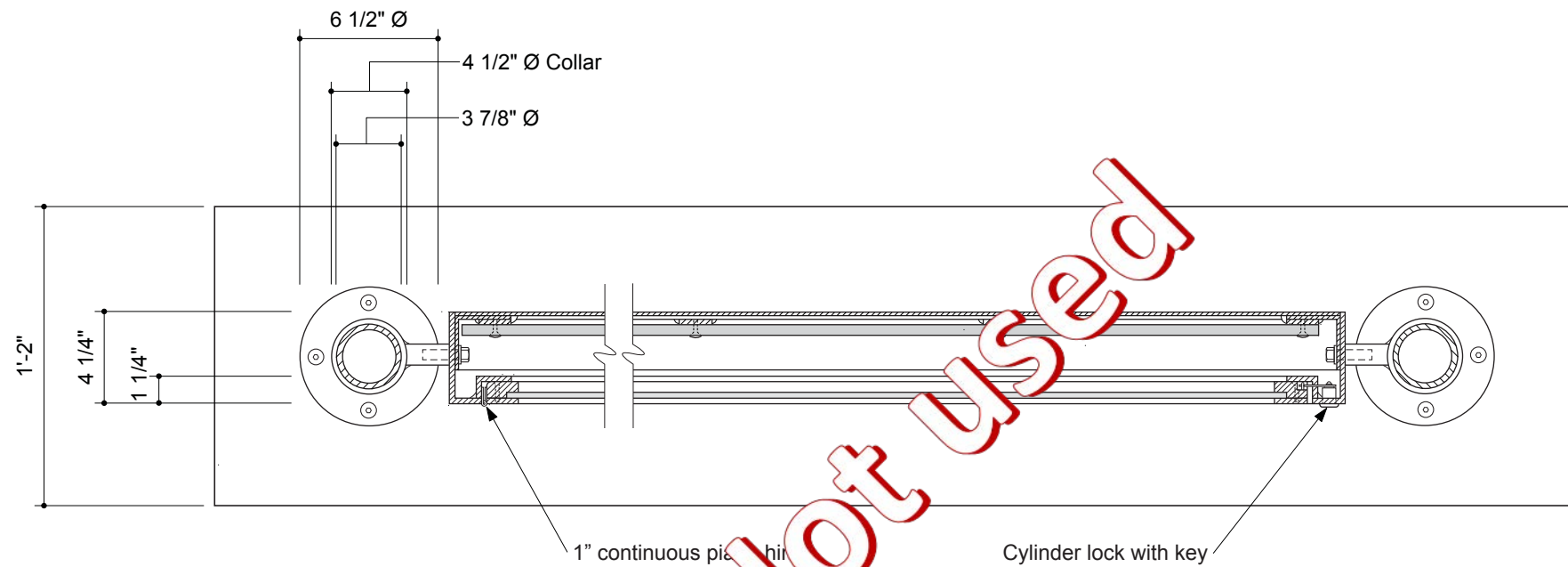

Not used

Welded 1/4" wall aluminum angle cabinet wrap with welds ground and filled smooth or hairline seams.

Welded 1/4" wall aluminum door frame face trim with welds ground and filled smooth.

3/4" x 1 1/4" aluminum flat bar retainer frame mechanically fastened to door face trim. Drilled and tapped using countersunk stainless steel screws.

1/4" thick clear lexan.

Fabricated .080 aluminum cabinet pan with all inside and outside painted surfaces.

Tan Nucork bulletin board with hardwood backer RAL 1003 Signal Yellow powder coat finish.

Welded 1 1/2", 1/4" thick, aluminum flat support framing welded to back of cabinet. Drill and tap to fasten graphic panel.

Countersunk mechanical fasteners around perimeter concealed behind door trim.

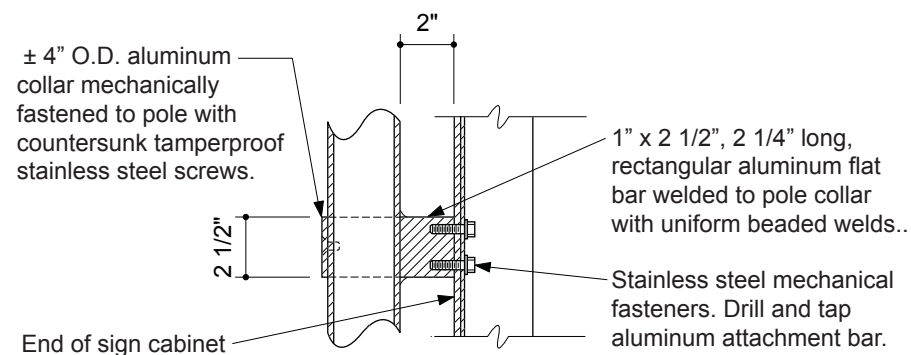
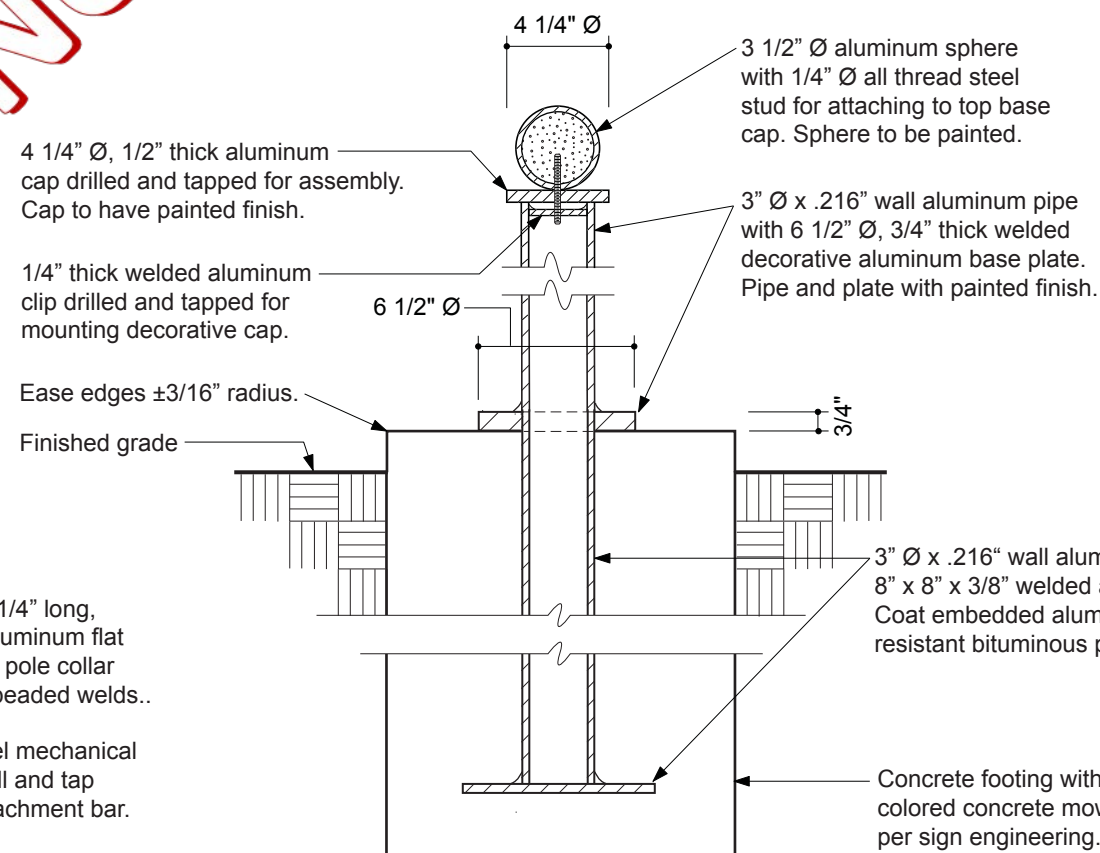
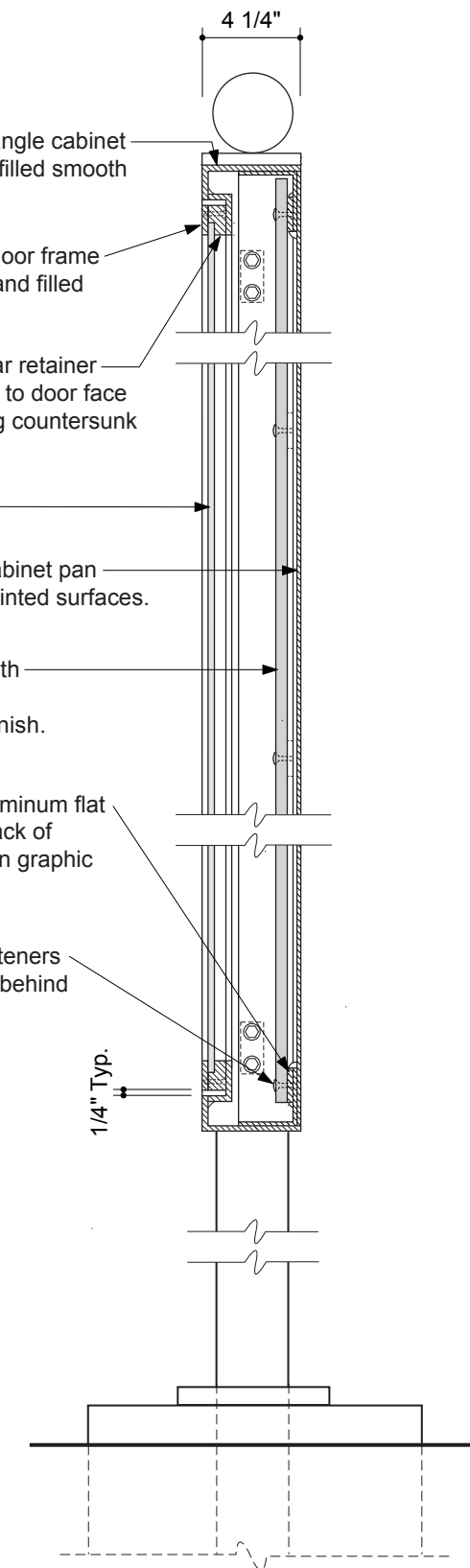

COAST SIGN, INC.
1345 S. ALLEC STREET
ANAHEIM, CA 92805

PAGE: 1 of 2
PROJECT: UC RIVERSIDE
SUBJECT: RIVERSIDE, CA
SIGN STRUCTURAL CALCS.
BY: DVM DATE: 10-3-07
P.O.# DWGS. FROM PERRY SHIMOJI

FOR COLUMN & FOOTING DESIGN

AREA -- SIGN TYPE W40.0 & W42.0
A = 3.5' * 5.25' = 18.4 S.F.
A = 6.88' * 0.25' * 2 COL. = 3.4 S.F.

NOTE: SIGN TYPE W42.0 IS SLIGHTLY
SMALLER IN SIZE THAN W40.0 -
COLUMN & FOOTING DESIGN FOR BOTH
IS O.K. BY INSPECTION

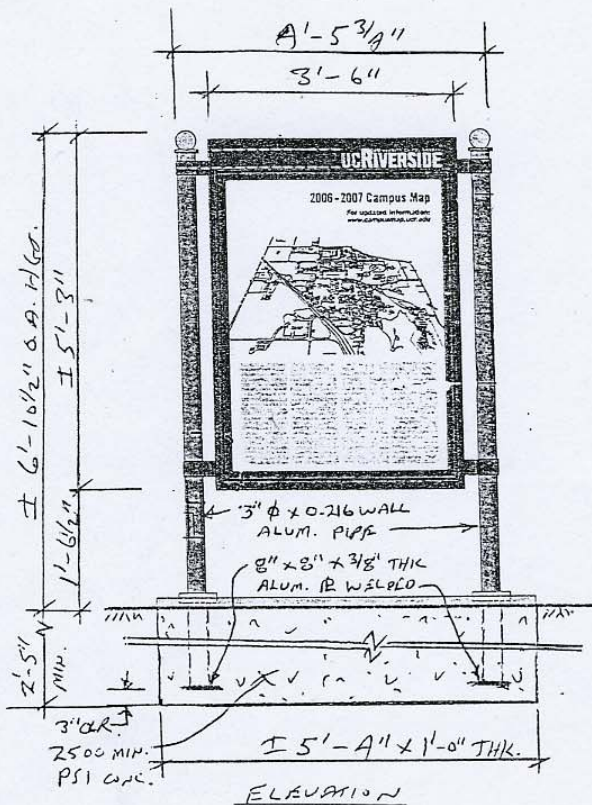

WIND	CBC-'01	80 MPH, EXP. C
CBC-1613	$p=Cq*Ce*Qs*I$	$I=1.0$
Qs =	16.4	Cq = 1.4
	25.94 LBS/S.F. @ 20'	Ce = 1.13
	24.34 LBS/S.F. < 15'	Ce = 1.06
S.F.	LBS	FT. FT. LBS
AREA	!PRESS!	X-DIST ! MOM-XX
18.4	448	4.26 1908
3.4	83	3.44 285
0.0	0	0.00 0
0.0	0	0.00 0

TOTAL	531	4.13	2192
		(AVE.)	
DOUBLE COLUMN			
MOM. 'K	1.10		

ALUM $F_y = 12$ K/SQ. IN.
S = M/Fb WIND 1/3 INCR.
S = 0.75 * M (INCL 1.33 WIND)
S = 0.82 IN³
t = 0.216 IN. (MIN. THK.)
S = .0982*(d⁴-d1⁴)/d
d = 3.5 d1 = 3.068
USE MIN. 3" DIA. x 0.216 ALUM. PIPE #40
S = 1.72 IN³ > 0.82
O.K.

WT. OF SIGN = 220 LBS
AXIAL STRESS IS NEGLIGIBLE

COAT ALUM. SURFACES EMBEDDED IN
CONC. WITH ONE HEAVY COAT OF
ALKALI-RESISTANT BITUMINOUS
(BITUMASTIC PAINT -- SUCH AS
HENRY'S OR EQUIVALENT).

SEE PAGE 2 FOR FOOTING DETAILS



HUNT DESIGN
25 N. MENTOR AVE.
PASADENA, CA 91106

PAGE: 2 of 2
PROJECT: UC RIVERSIDE
SUBJECT: RIVERSIDE, CA
SIGN STRUCTURAL CALCS.
BY: DVM DATE: 10-1-07
P.O.# DWGS. FROM PERRY SHIMOJI

SINGLE FOOTING - STRAIGHT
DESIGN OF EMBEDDED POLE FOOTINGS

DESCRIPTION	>>	64" WIDE		
	>>	X 12" THK.		
ALLOW PASSIVE	psf	200	200	200
MAX PASSIVE	psf	1,500	1,500	1,500
LOAD DURATION FACTOR		1.33	1.33	1.33
POINT LOAD	lbs	531	0	0
LOAD H	ft	4.13	0.00	0.00
DIST. L	#/ft	0	0	0
ST. H	ft	0.00	0.00	0.00
E	ft	0.00	0.00	0.00
DIAMETER	in	64"	0	0
CIRCULAR ?	y/n	N	N	N
RESTRAINED ?	y/n	N	N	N
SUMMARY				
Moments @ Surface:				
Point Load	ft-#	2,193	0	0
Uniform Load	ft-#	0	0	0
... Total Moment	ft-#	2,193	0	0
Total Lateral Load	#	531	0	0
--- NON-RESTRAINED ---				
Min. Req'd Embedment				
$A(1+(1+4.36h/A)^.5)/2$		2'-5"		
$A=2.34P/(S 1 b)$	ft	2.34'	0.00	0.00
Press @ 1/3 Embed.:				
Actual	psf	207	0	0
Allowable	psf	207	0	0
--- RESTRAINED ---				
Min. Req'd Embedment				
$(4.25 P h/S3 b)^.5$	ft	0.00	0.00	0.00
Pressure @ Bottom				
Actual	psf	0	0	0
Allowable	psf	0	0	0
Surface Restraint Force				
	lbs	0	0	0

PER CBC TABLE 18-1-A
POLE 2x ALLOWABLE



JOB NO. HUNT-146

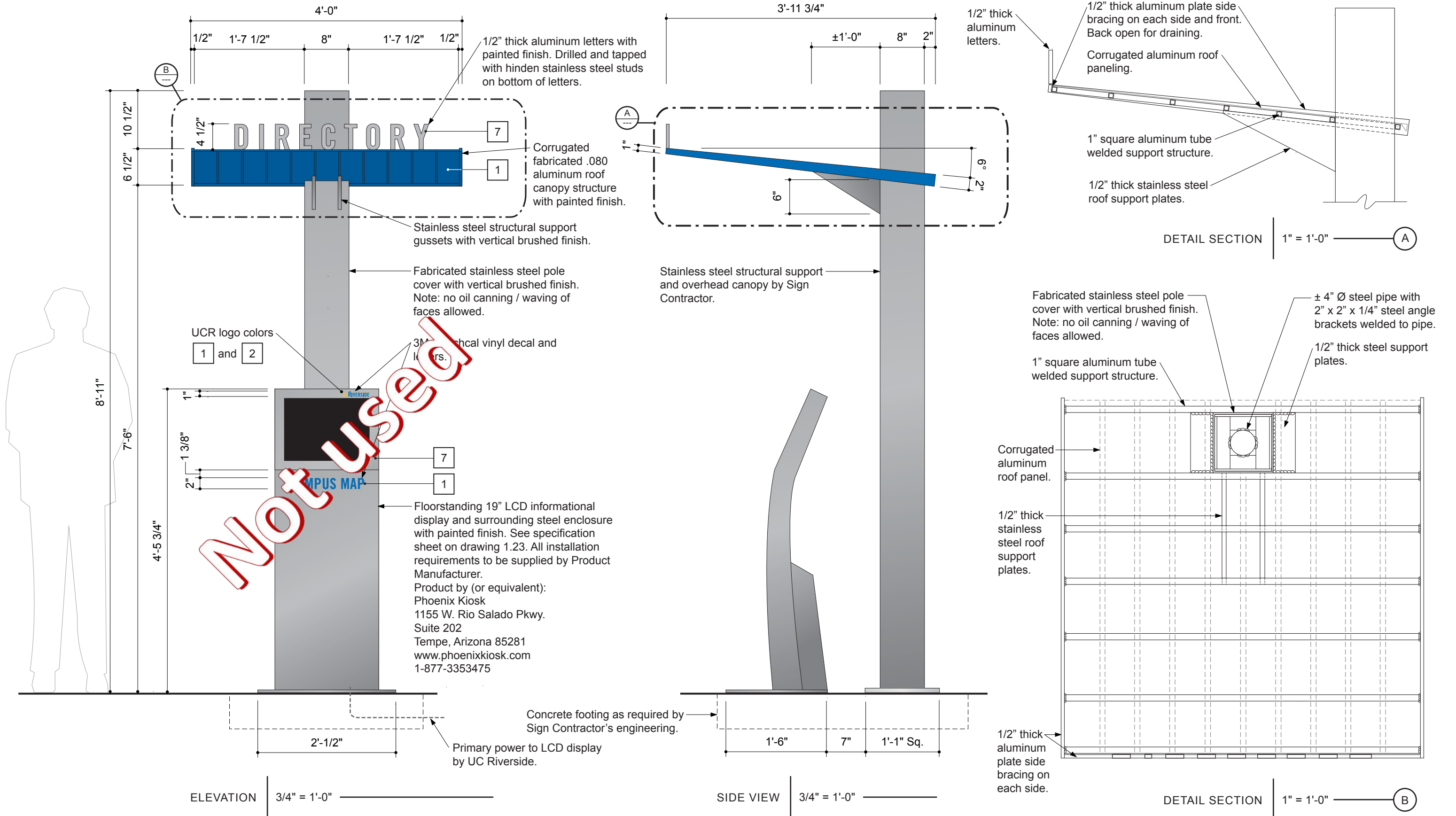



Product Name: Sliivr (sli-ver) Type: Floorstanding



DESCRIPTION:

Proof that true beauty is more than skin deep. The standard 19" LCD display is highlighted by the architecture of the surrounding steel enclosure. The internal peripherals are designed for quick cold swapping and easy, unobtrusive maintenance. Designed to be the perfect informational kiosk, the Sliivr is the choice for free standing directory, way-finding and in-store cataloging applications.

DIMENSIONS:

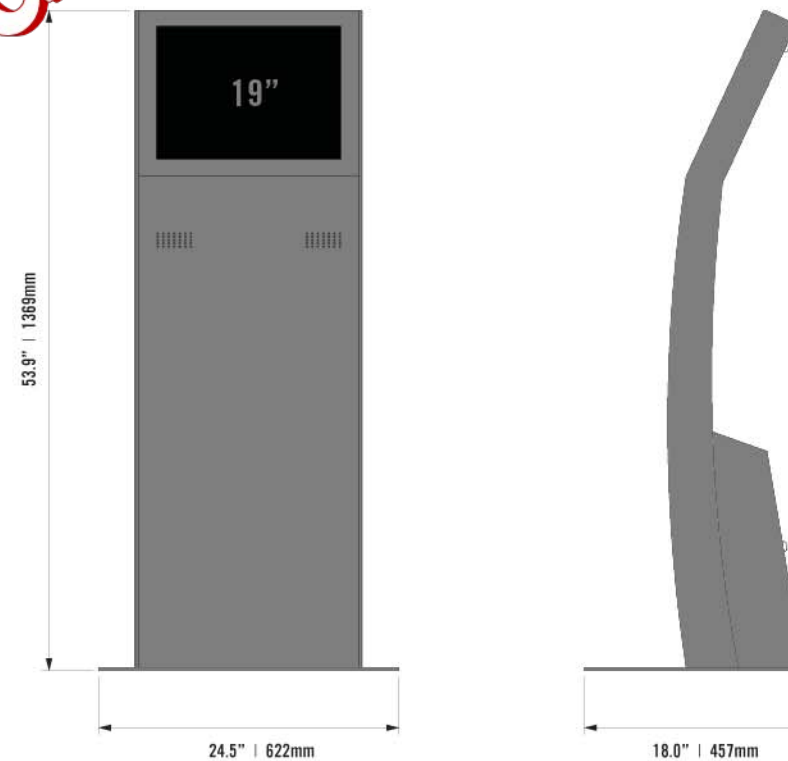

INCLUDED W/ BASE MODEL:

- 19" LCD Display
- Powder Coated Steel Side Accent Blades
- Large Access Doors with Tubular Locks/Keys
- Tempered Glass Display Overlay (Certain UI Options Only)
- Cooling Fan
- Industrial Power Strip
- 2.5 Watt Speakers / 8 Ohm Impedance

SPECIFICATIONS:

- Precision cut, 16 gauge steel enclosure
- Full Interior MIG Welds / Custom Brackets & Mounts
- Cardinal Industrial Powder Coat Finish
- Kiosk Temp Range:
- Operating: 42-90° F
- Stored: 33-100° F

OPTIONS:

- Installation / Warranty
- Custom & Off The Shelf Software
- PC & PC Upgrades
- Branding & Graphics
- Accent Blade Color Options
- Multimedia
- Custom Finishes
- User Input Devices
- Card Readers / Scanners
- Custom Component Integration
- Shipping & Delivery

WEIGHT:

Kiosk Base Weight: ** 120lbs
 ** Shipping weight and cost will vary depending on options selected

Not Used

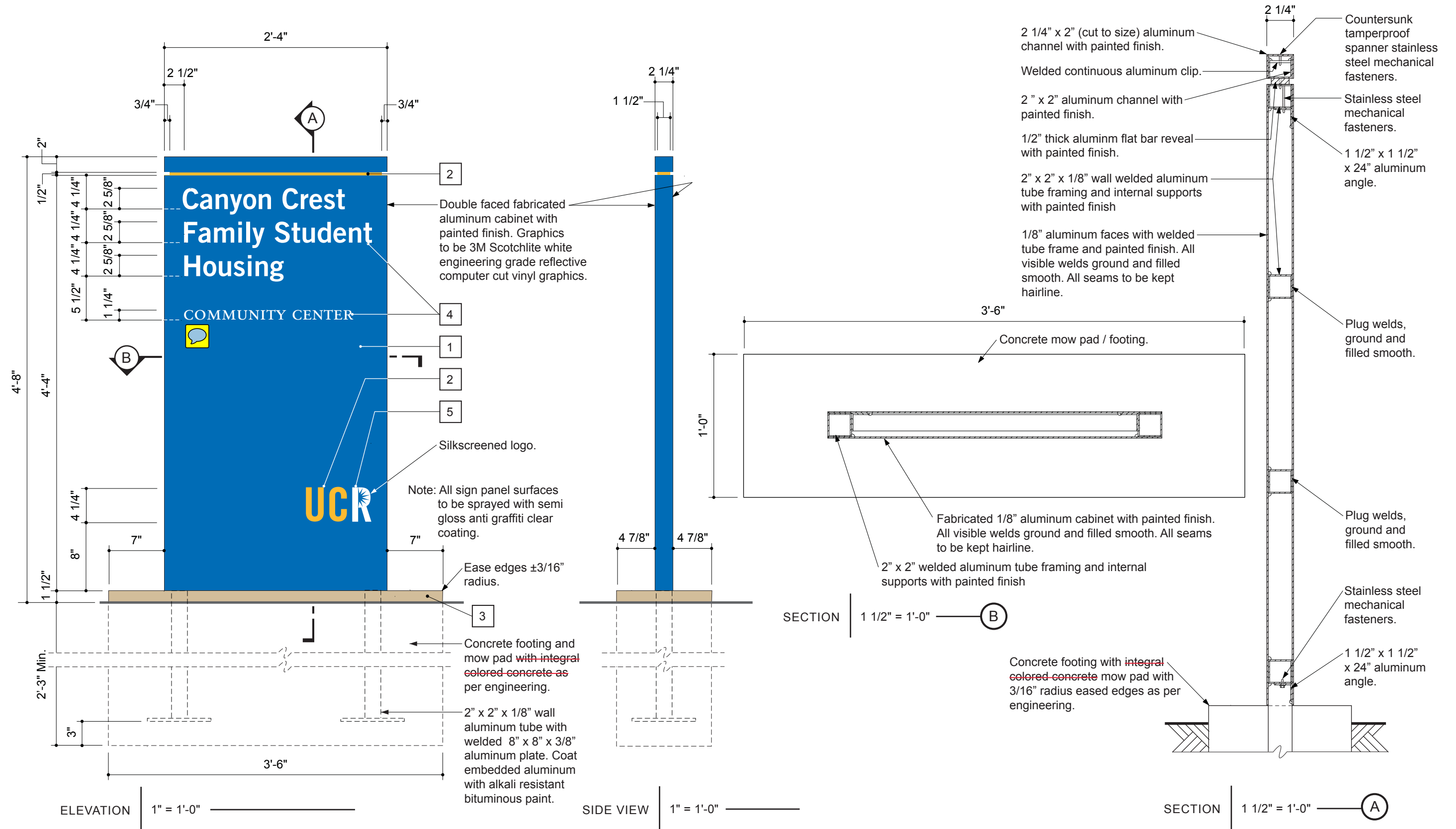

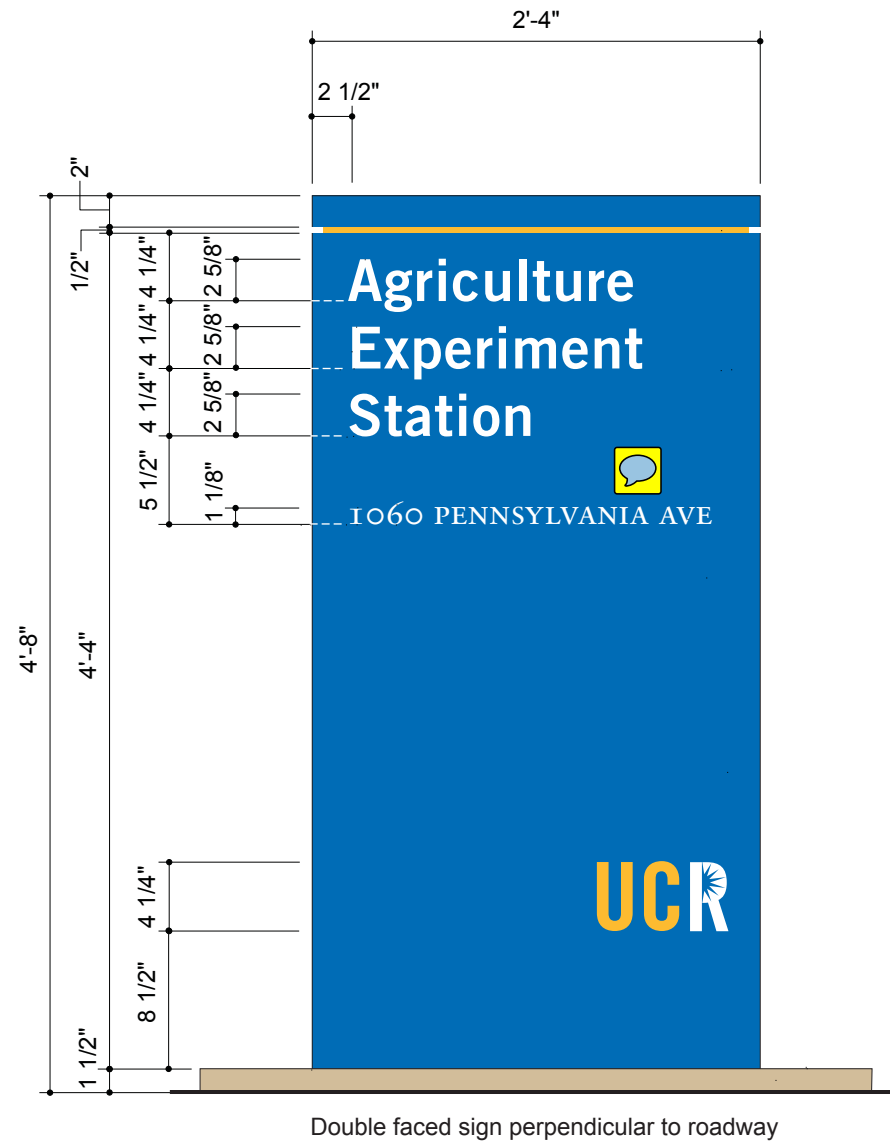

Double faced sign perpendicular to roadway

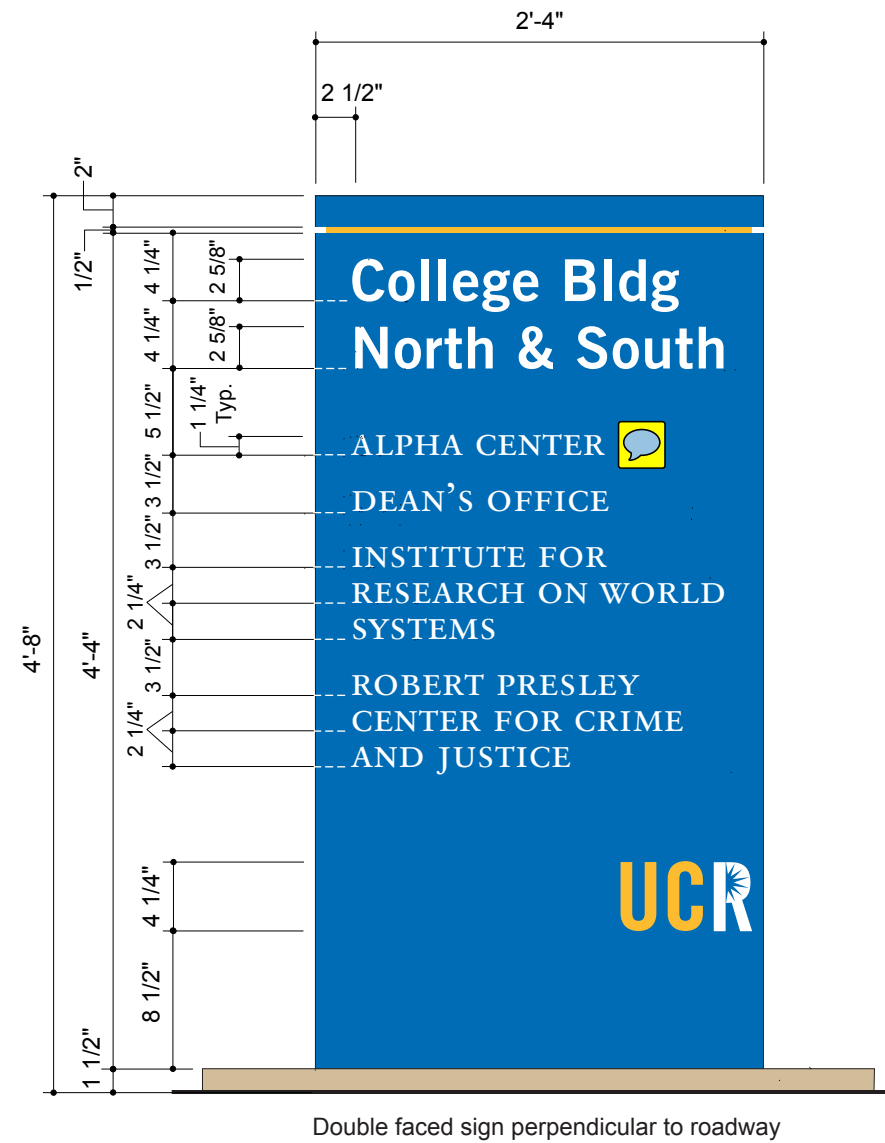

Double faced sign perpendicular to roadway

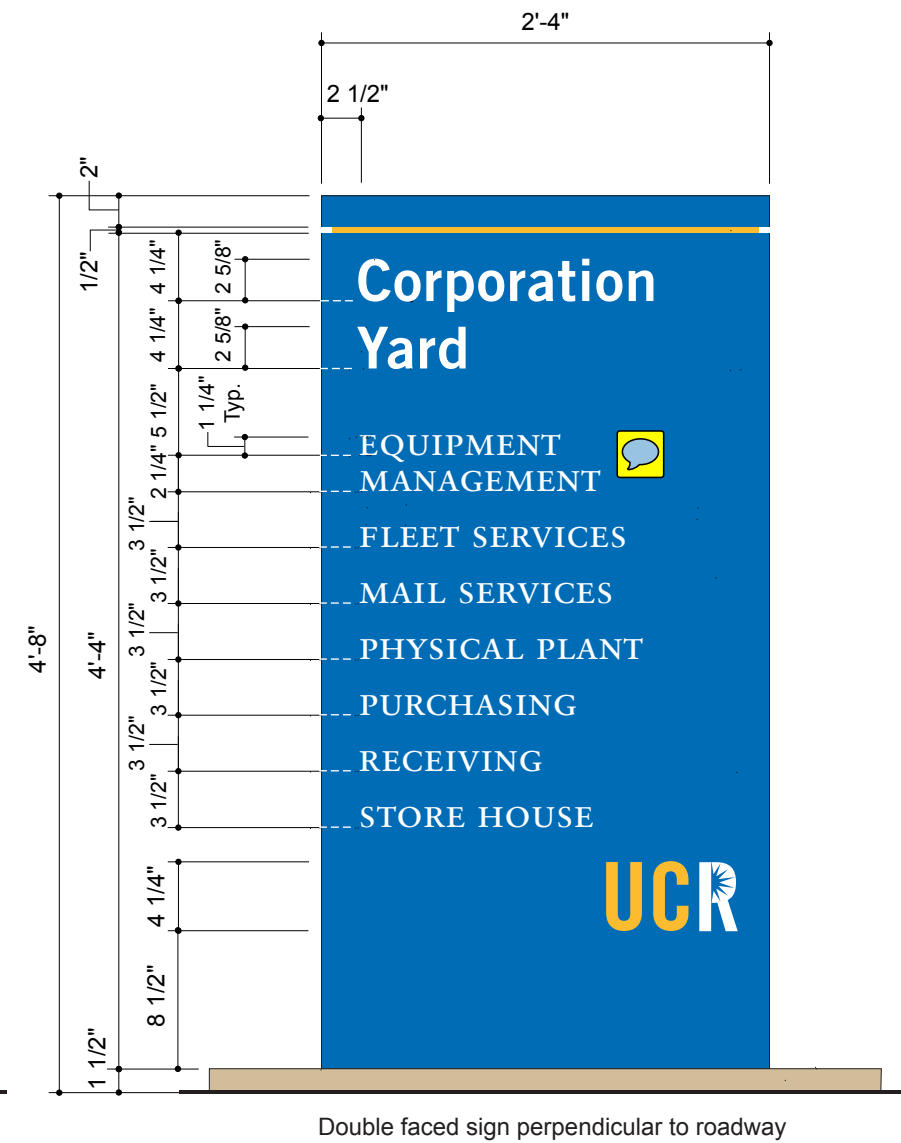

Double faced sign perpendicular to roadway

LAYOUT CONDITIONS

1" = 1'-0"

See Sheet 1.27, Sign Type W50, for Specifications

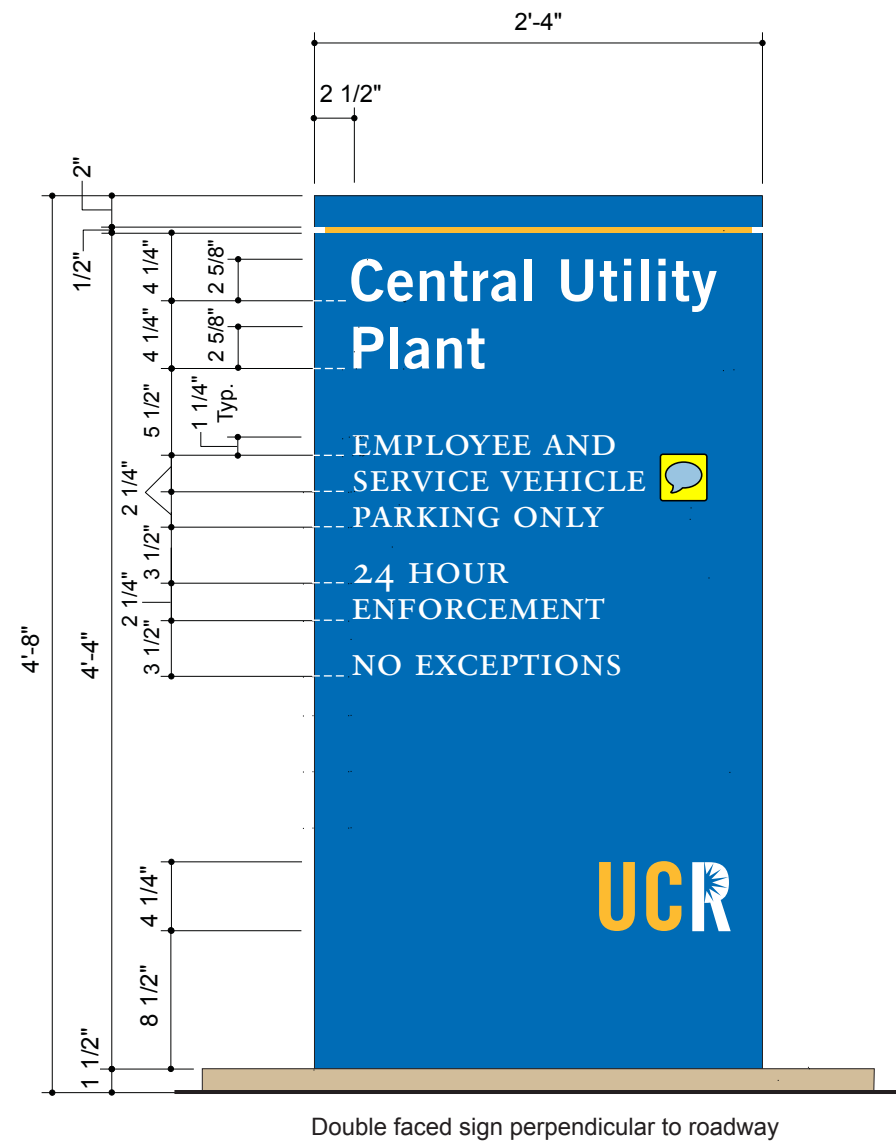
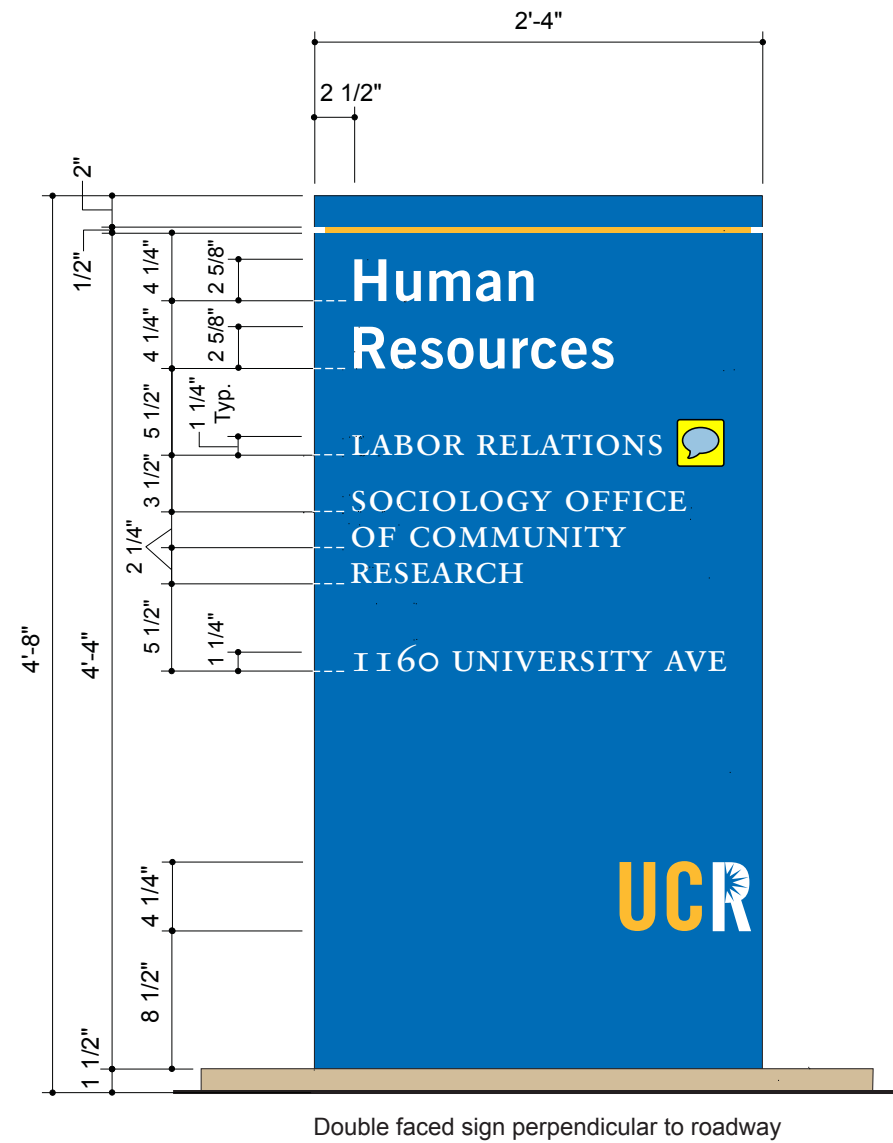

LAYOUT CONDITIONS

1" = 1'-0"

See Sheet 1.27, Sign Type W50, for Specifications

HUNT DESIGN
25 N. MENTOR AVE.
PASADENA, CA 91106

PAGE: 1 of 2
PROJECT: UC RIVERSIDE
SUBJECT: RIVERSIDE, CA
SIGN STRUCTURAL CALCS.
BY: DVM DATE: 10-1-07
P.O.# DWGS. FROM PERRY SHIMOJI

FOR COLUMN & FOOTING DESIGN

AREA -- SIGN TYPES W50.0 & W70.0
A = 5.29' * 2.96' = 15.7 S.F. (TYPE W70.0)

NOTE: SIGN TYPE W50.0 IS SLIGHTLY
SMALLER IN SIZE THAN TYPE W70.0 -
COLUMN & FOOTING DESIGN FOR BOTH
IS O.K. BY INSPECTION

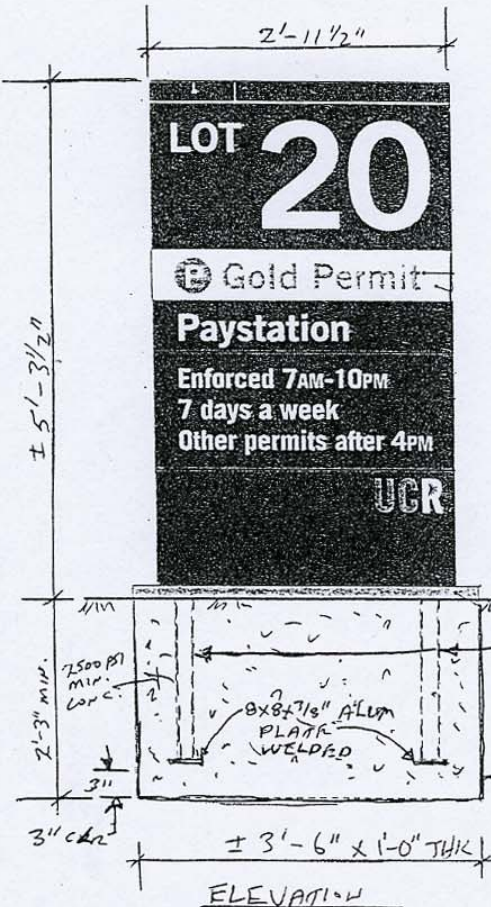

JOB NO. HUNT-144

WIND	CBC-'01	80 MPH, EXP. C
CBC-1613	$p=Cq \cdot Ce \cdot Qs \cdot I$	$I=1.0$
$Qs =$	16.4	$Cq = 1.4$
	25.94 LBS/S.F. @ 20'	$Ce = 1.13$
	24.34 LBS/S.F. < 15'	$Ce = 1.06$
S.F.	LBS	FT.
AREA	!PRESS!	X-DIST
15.7	382	2.65
0.0	0	0.00
0.0	0	0.00
0.0	0	0.00

TOTAL	382	2.65	1013
		(AVE.)	
DOUBLE COLUMN			
MOM. 'K	0.51		

ALUM $F_b = 12$ K/SQ. IN.
 $S = M/F_b$ WIND 1/3 INCR.
 $S = 0.75 \cdot M$ (INCL 1.33 WIND)
 $S = 0.38$ IN³

$S = (bd^3 - b1 \cdot d1^3) / (6 \cdot d)$
 $d = 2$ $d1 = 1.75$
 $b = 2$ $b1 = 1.75$

USING 2"x2"x 1/8" ALUM. TUBE
 $S = 0.55$ IN³ > 0.38
O.K.

COAT ALUM. SURFACES EMBEDDED IN
CONC. WITH ONE HEAVY COAT OF
ALKALI-RESISTANT BITUMINOUS
(BITUMASTIC) PAINT TO 2" MIN.
ABOVE GRADE

WT. OF SIGN = 175 LBS +/-
AXIAL STRESS IS NEGLIGIBLE

SEE PAGE 2 FOR FOOTING DETAILS



HUNT DESIGN
25 N. MENTOR AVE.
PASADENA, CA 91106

PAGE: 2 of 2
PROJECT: UC RIVERSIDE
SUBJECT: RIVERSIDE, CA
SIGN STRUCTURAL CALCS.
BY: DVM DATE: 10-1-07
P.O.# DWGS. FROM PERRY SHIMOJI

SINGLE FOOTING - STRAIGHT

DESIGN OF EMBEDDED POLE FOOTINGS

DESCRIPTION	>>	42" WIDE		
	>>	+ 12" THK.		
ALLOW PASSIVE	psf	200	200	200
MAX PASSIVE	psf	1,500	1,500	1,500
LOAD DURATION FACTOR		1.33	1.33	1.33
POINT LOAD	lbs	382	0	0
LOAD HT.	ft	2.65	0.00	0.00
DIST. LOAD	#/ft	0	0	0
START HT.	ft	0.00	0.00	0.00
END HT.	ft	0.00	0.00	0.00
WIDTH/DIAMETER	in	42	0	0
CIRCULAR ?	y/n	N	N	N
RESTRAINED ?	y/n	N	N	N
SUMMARY				
Moments @ Surface:				
Point Load	ft-#	1,012	0	0
Uniform Load	ft-#	0	0	0
... Total Moment	ft-#	1,012	0	0
Total Lateral Load	#	382	0	0
NON-RESTRAINED				
Min. Req'd Embedment		2'-3"		
$A(1+(1+4.36h/A)^{.5})/2$	ft	2.18'	0.00	0.00
$A=2.34P/(S \cdot 1 \cdot b)$		DEPTH		
Press @ 1/3 Embed.:				
Actual	psf	194	0	0
Allowable	psf	193	0	0
RESTRAINED				
Min. Req'd Embedment		0.00	0.00	0.00
$(4.25 P h / S3 b)^{.5}$ ft				
Pressure @ Bottom				
Actual	psf	0	0	0
Allowable	psf	0	0	0
Surface Restraint Force	lbs	0	0	0

PER CBC TABLE 18-1-A
POLE 2X ALLOWABLE



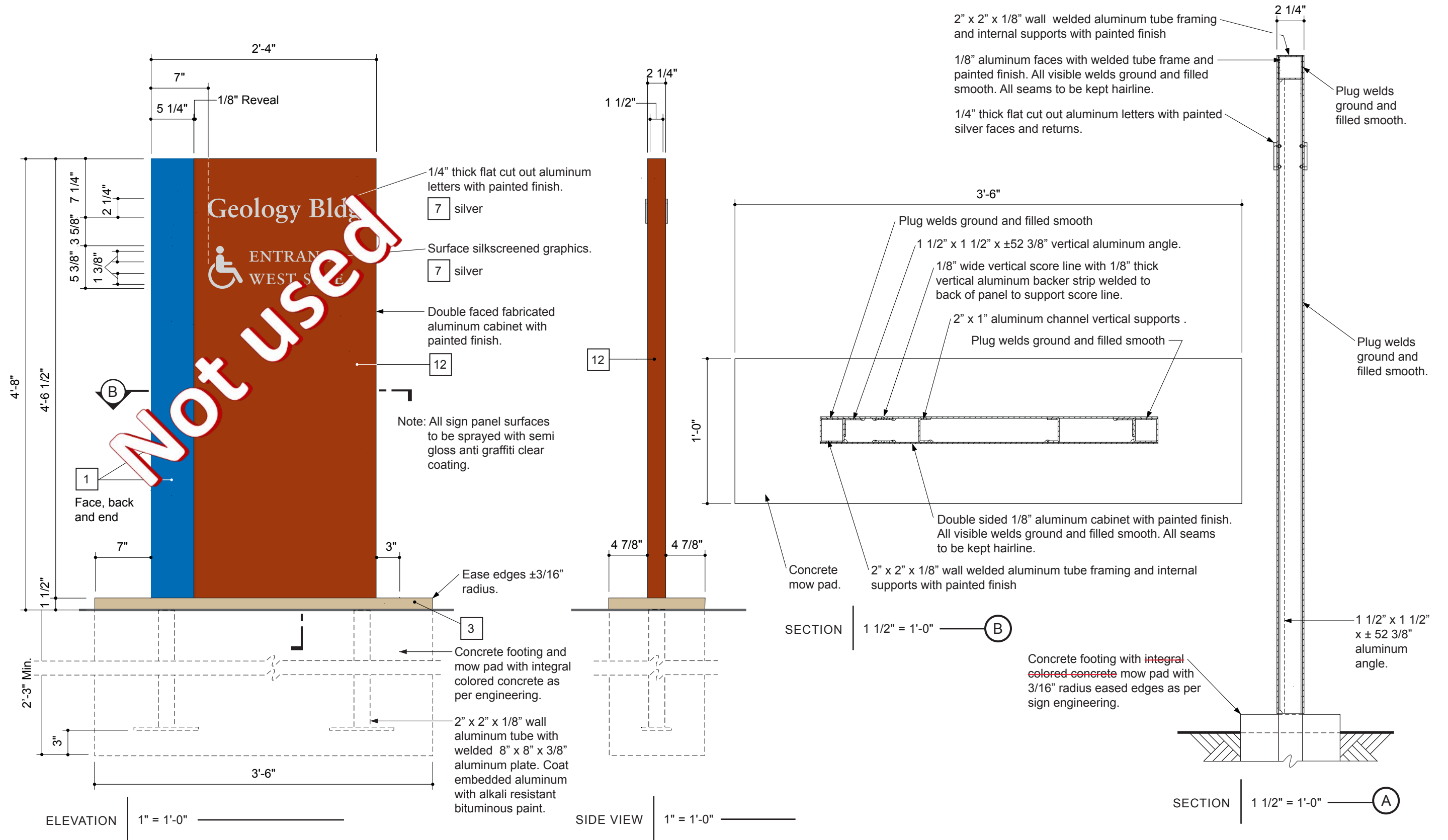

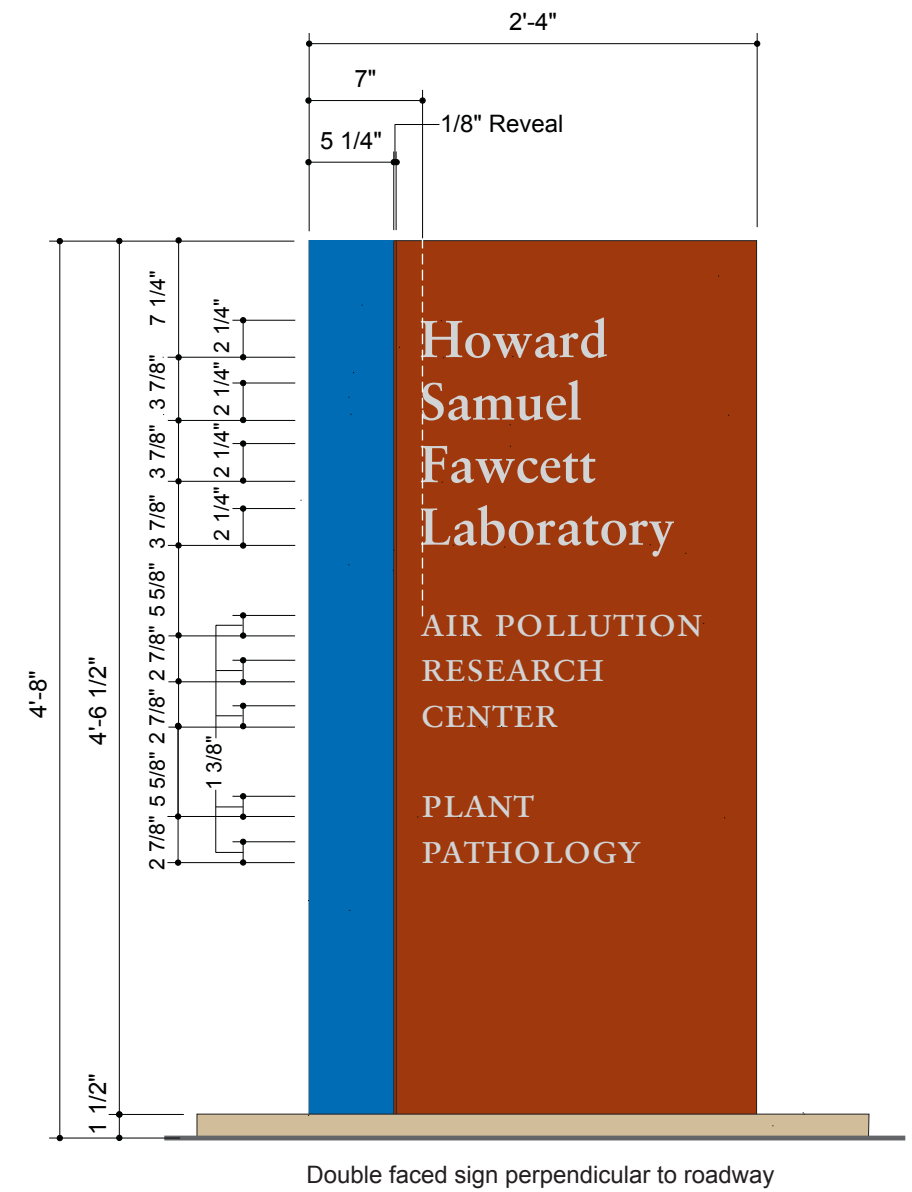
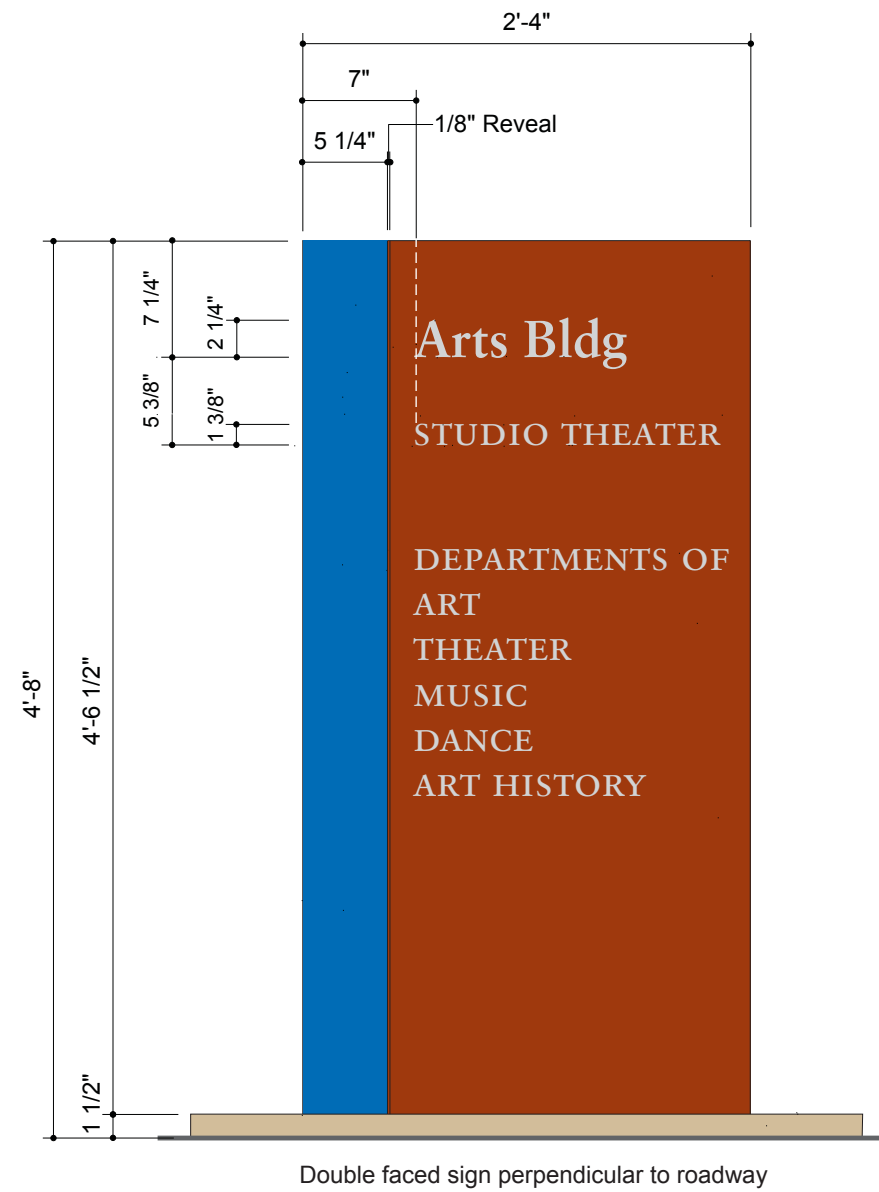
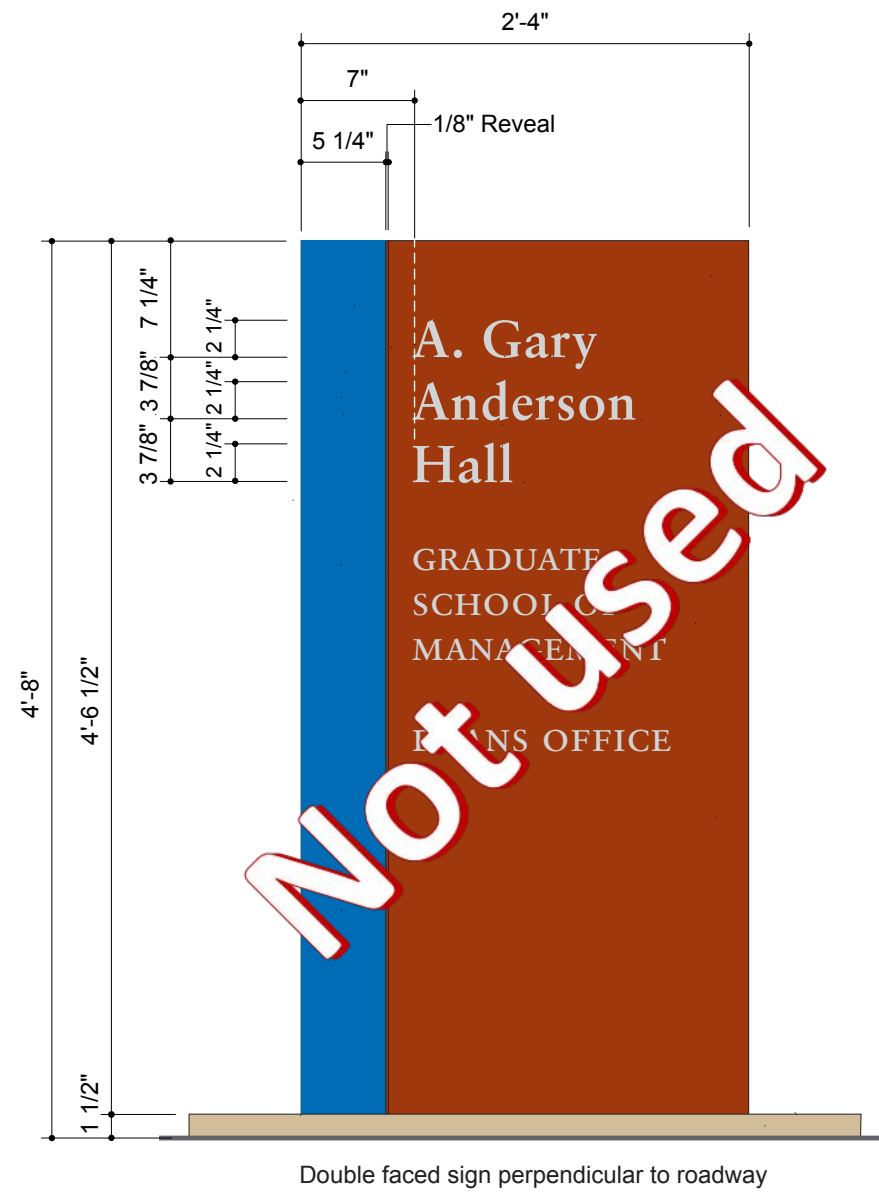

LAYOUT CONDITIONS | 1" = 1'-0" ————— See Sheet 1.31, Sign Type W51, for Specifications

HUNT DESIGN
25 N. MENTOR AVE.
PASADENA, CA 91106

PAGE: 1 of 2
PROJECT: UC RIVERSIDE
SUBJECT: RIVERSIDE, CA
SIGN STRUCTURAL CALCS.
BY: DVM DATE: 10-1-07
P.O.# DWGS. FROM PERRY SHIMOJI

FOR COLUMN & FOOTING DESIGN

AREA -- SIGN TYPES W50.0 & W70.0
A = 5.29' * 2.96' = 15.7 S.F. (TYPE W70.0)

NOTE: SIGN TYPE W50.0 IS SLIGHTLY
SMALLER IN SIZE THAN TYPE W70.0 -
COLUMN & FOOTING DESIGN FOR BOTH
IS O.K. BY INSPECTION

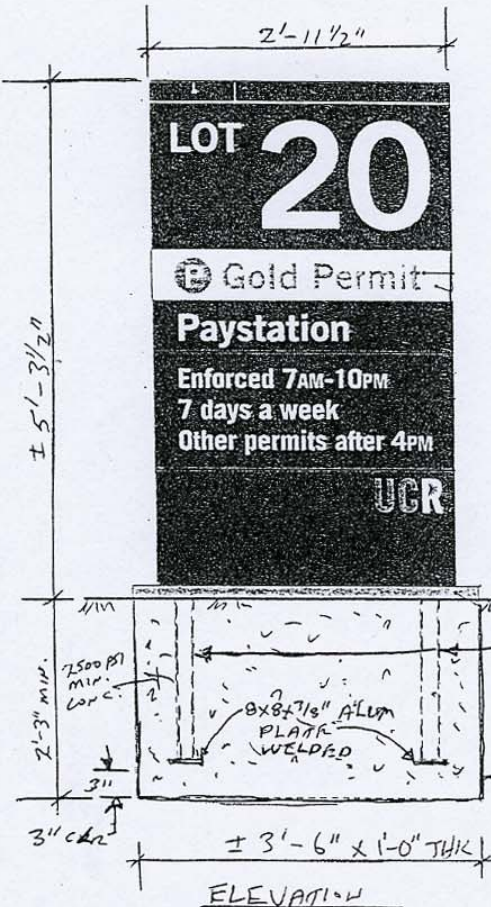

JOB NO. HUNT-144

WIND CBC-'01 80 MPH, EXP. C

CBC-1613	$p=Cq \cdot Ce \cdot Qs \cdot I$	$I=1.0$
$Qs =$	16.4	$Cq = 1.4$
	$25.94 \text{ LBS/S.F. @ } 20'$	$Ce = 1.13$
	$24.34 \text{ LBS/S.F. } < 15'$	$Ce = 1.06$
S.F.	LBS	FT.
AREA	!PRESS!	X-DIST
15.7	382	2.65
0.0	0	0.00
0.0	0	0.00
0.0	0	0.00

TOTAL 382 2.65 1013 (AVE.)

DOUBLE COLUMN MOM.'K 0.51

ALUM $F_b = 12 \text{ K/SQ. IN.}$
 $S = M/F_b$ WIND 1/3 INCR.
 $S = 0.75 \cdot M$ (INCL 1.33 WIND)
 $S = 0.38 \text{ IN}^3$

$S = (bd^3 - b1 \cdot d1^3) / (6 \cdot d)$
 $d = 2$ $d1 = 1.75$
 $b = 2$ $b1 = 1.75$

USING 2"x2"x 1/8" ALUM. TUBE
 $S = 0.55 \text{ IN}^3 > 0.38$
O.K.

COAT ALUM. SURFACES EMBEDDED IN
CONC. WITH ONE HEAVY COAT OF
ALKALI-RESISTANT BITUMINOUS
(BITUMASTIC) PAINT TO 2" MIN.
ABOVE GRADE

WT. OF SIGN = 175 LBS +/-
AXIAL STRESS IS NEGLIGIBLE

SEE PAGE 2 FOR FOOTING DETAILS



HUNT DESIGN
25 N. MENTOR AVE.
PASADENA, CA 91106

PAGE: 2 of 2
PROJECT: UC RIVERSIDE
SUBJECT: RIVERSIDE, CA
SIGN STRUCTURAL CALCS.
BY: DVM DATE: 10-1-07
P.O.# DWGS. FROM PERRY SHIMOJI

SINGLE FOOTING - STRAIGHT

DESIGN OF EMBEDDED POLE FOOTINGS

DESCRIPTION	>>	42" WIDE	>>	PER CBC TABLE 18-1-A POLE 2X ALLOWABLE
		+ 12" THK.		
ALLOW PASSIVE	psf	200	200	200
MAX PASSIVE	psf	1,500	1,500	1,500
LOAD DURATION FACTOR		1.33	1.33	1.33
POINT LOAD	lbs	382	0	0
LOAD HT.	ft	2.65	0.00	0.00
DIST. LOAD	#/ft	0	0	0
START HT.	ft	0.00	0.00	0.00
END HT.	ft	0.00	0.00	0.00
WIDTH/DIAMETER	in	42"	0	0
CIRCULAR ?	y/n	N	N	N
RESTRAINED ?	y/n	N	N	N
SUMMARY				
Moments @ Surface:				
Point Load	ft-#	1,012	0	0
Uniform Load	ft-#	0	0	0
... Total Moment	ft-#	1,012	0	0
Total Lateral Load	#	382	0	0
NON-RESTRAINED				
Min. Req'd Embedment				
$A(1+(1+4.36h/A)^{.5})/2$	ft	2'-3"		
$A=2.34P/(S \cdot 1 \cdot b)$	ft	2.18'	0.00	0.00
Press @ 1/3 Embed.:				
Actual	psf	194	0	0
Allowable	psf	193	0	0
RESTRAINED				
Min. Req'd Embedment				
$(4.25 P h / S3 b)^{.5}$	ft	0.00	0.00	0.00
Pressure @ Bottom				
Actual	psf	0	0	0
Allowable	psf	0	0	0
Surface Restraint Force	lbs	0	0	0



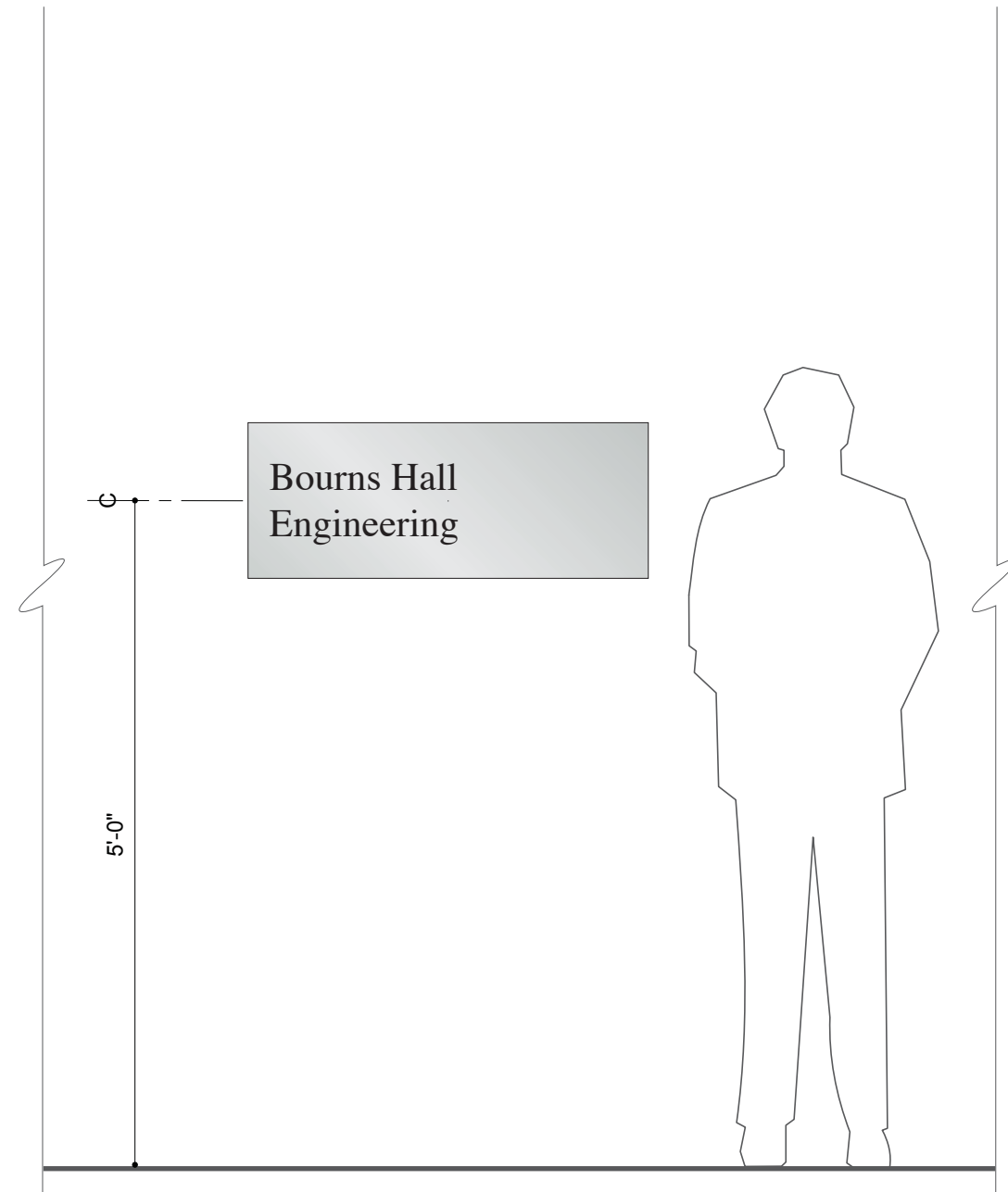

ELEVATION | 3/4" = 1'-0"

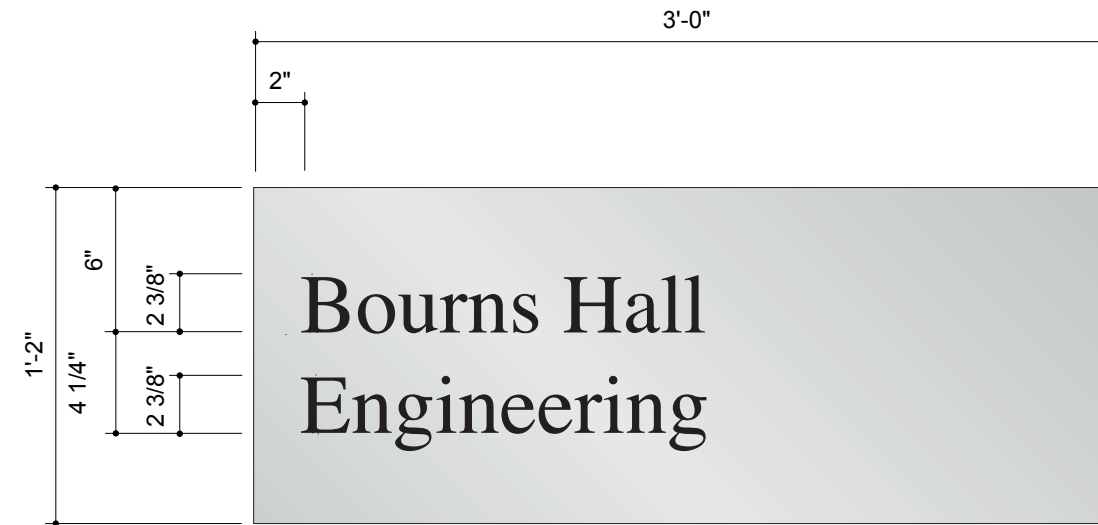

TWO LINE LAYOUT | 1 1/2" = 1'-0"

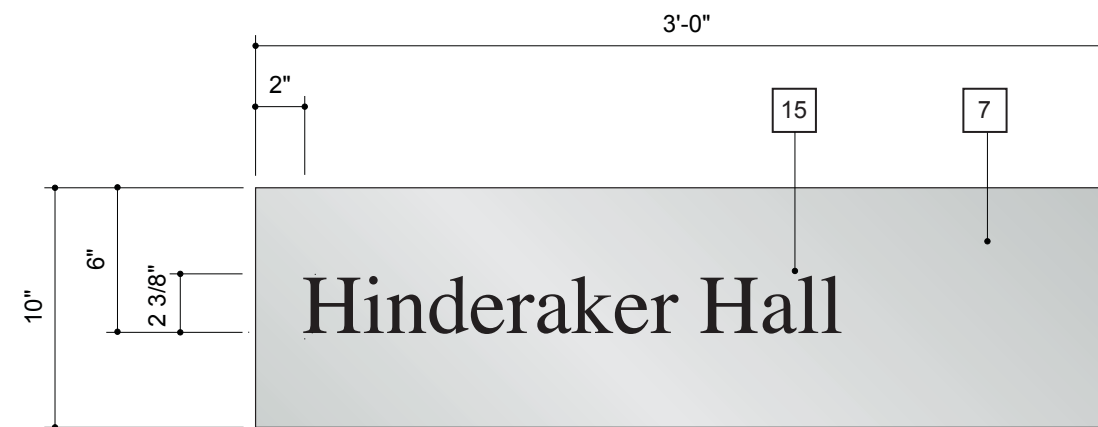

ONE LINE LAYOUT | 1 1/2" = 1'-0"

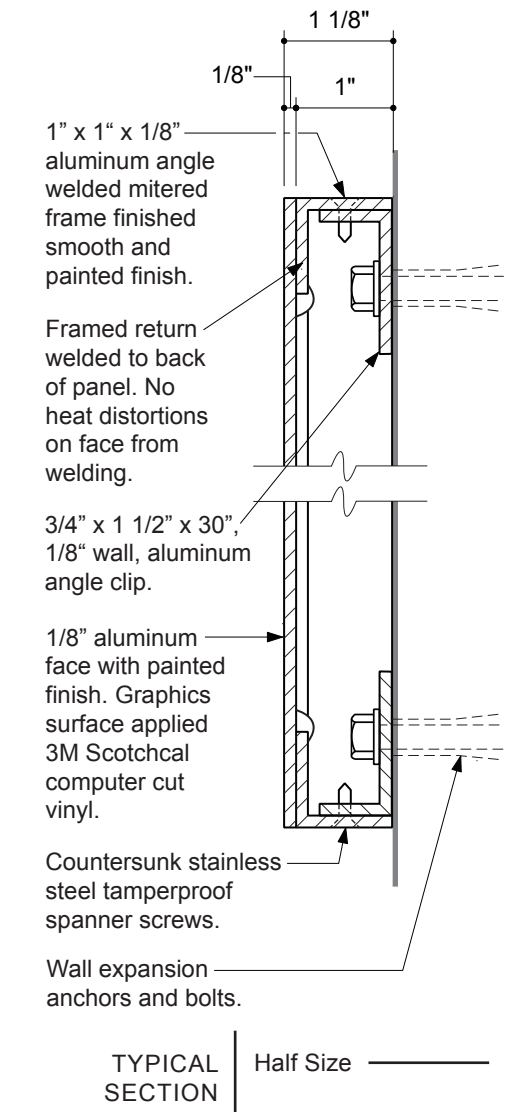

1 1/8" deep fabricated aluminum panel with painted finish. Graphics surface applied 3M Scotchlcal computer cut vinyl.

TYPICAL SECTION | Half Size

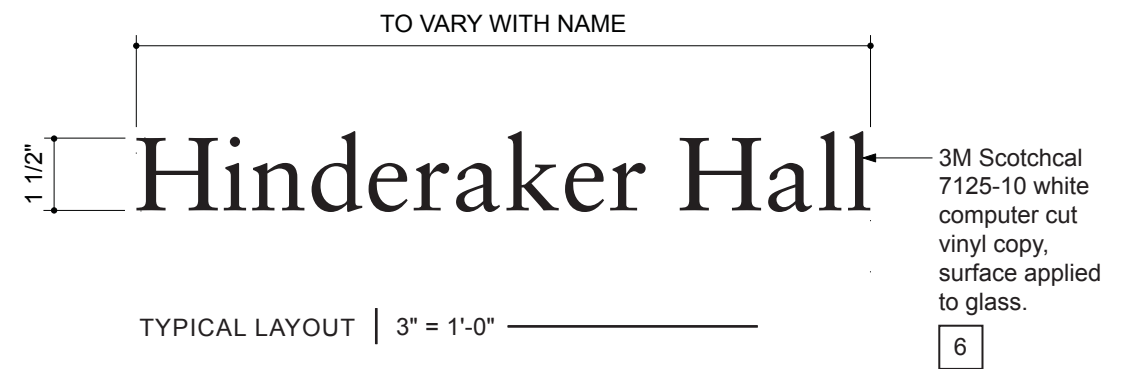
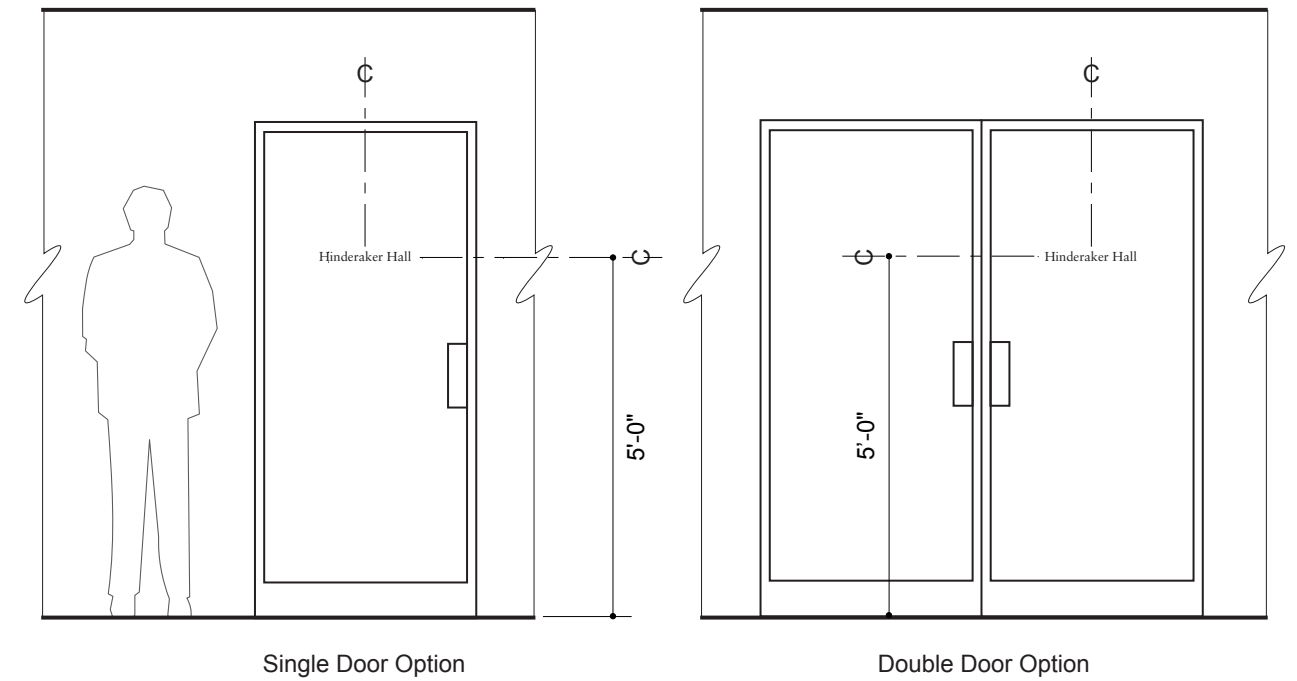
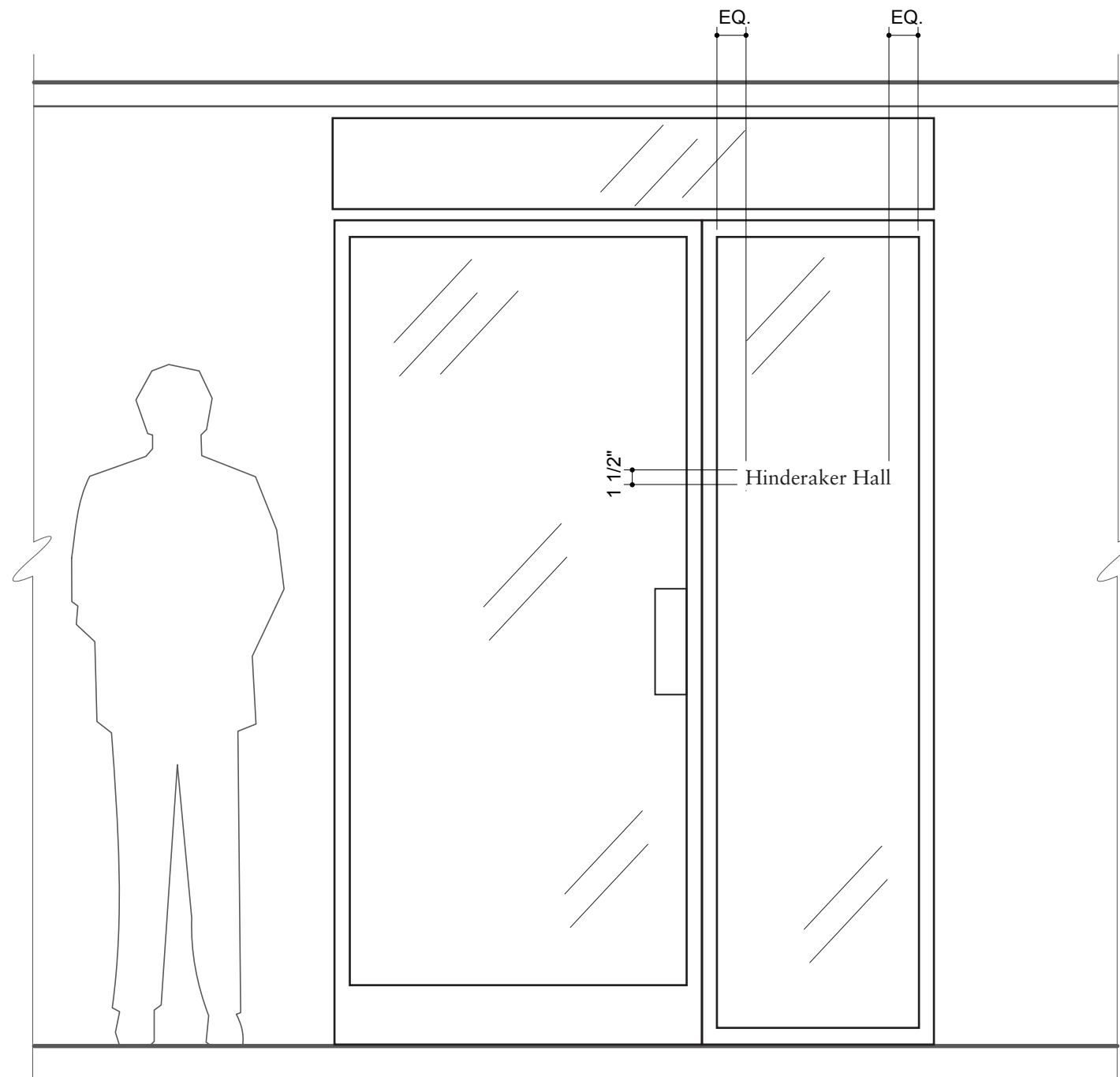



Exact placement to be determined in field.

Font: Frutiger 65 (BOLD) • Cast Aluminum • Letters with horizontally brushed finish • 10" high, wall mounted • 1/2" stand-offs from wall, preferably affixed to monolithic facade material (depending on building design)

Depending on height of letter location on the building, confer with PD&C on correct letter height. 3 digit

Fire address required per code (3 digits of Capital Asset Account No. (CAAN) - contact Campus Space Manager and Campus Fire Marshall)

TWO SETS of building identification and fire address are required for each building

LOCATION ELEVATION | N.T.S. _____



ELEVATION | 3/4" = 1'-0" _____

Standard Times Bold cast bronze letters with 1/2" stainless steel stand-offs from wall.

Bold cast bronze letters with 1/2" stainless steel stand-offs from wall.

Stainless steel all thread studs with wall mounting holes filled with 2-part epoxy adhesive.

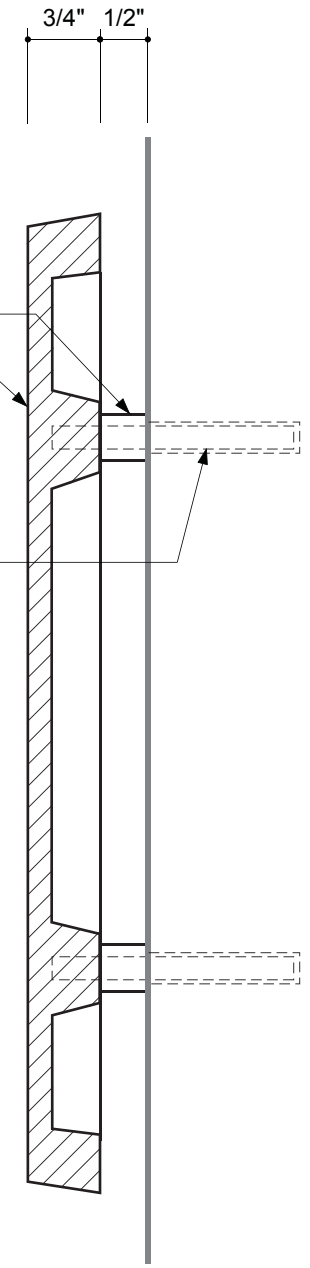

TYPICAL LETTER SECTION | 3/4" = 1'-0" _____

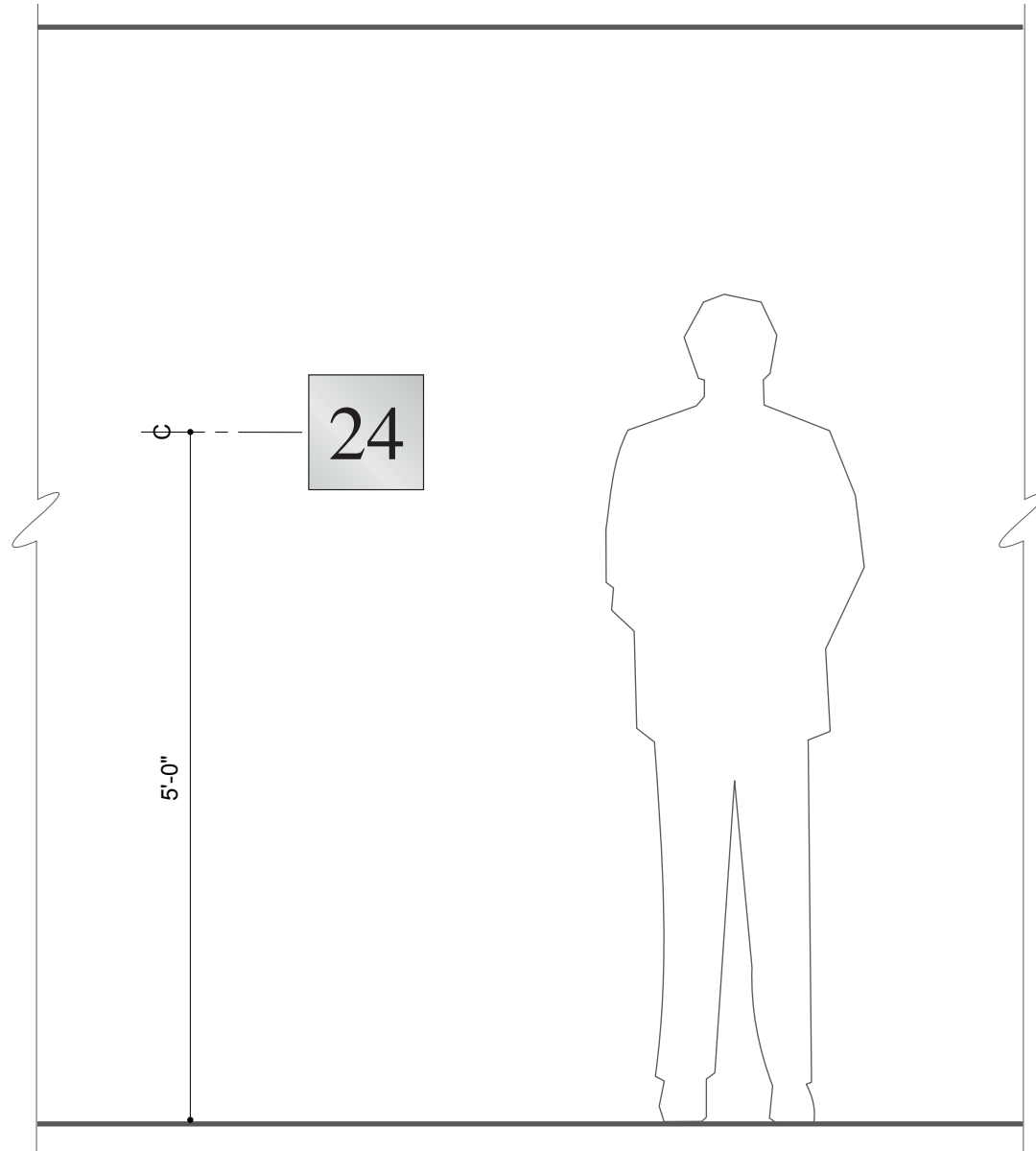

ELEVATION | 3/4" = 1'-0"

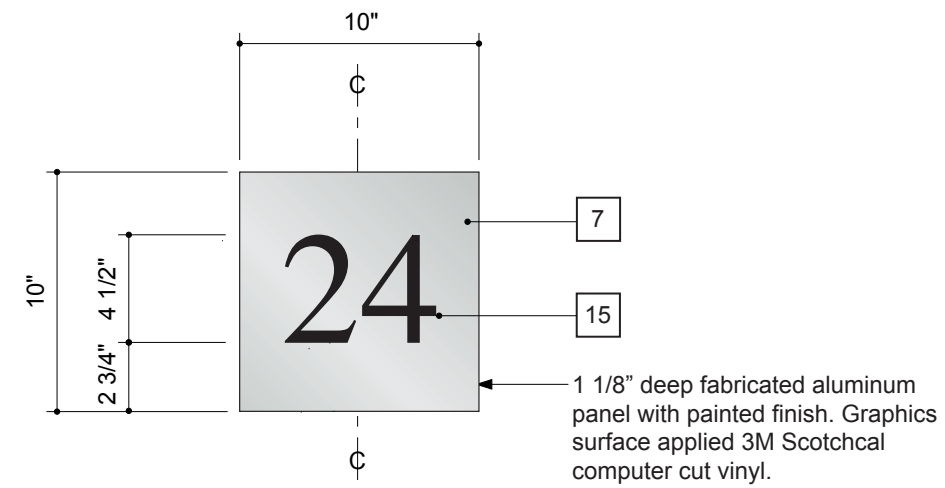

LAYOUT | 1 1/2" = 1'-0"

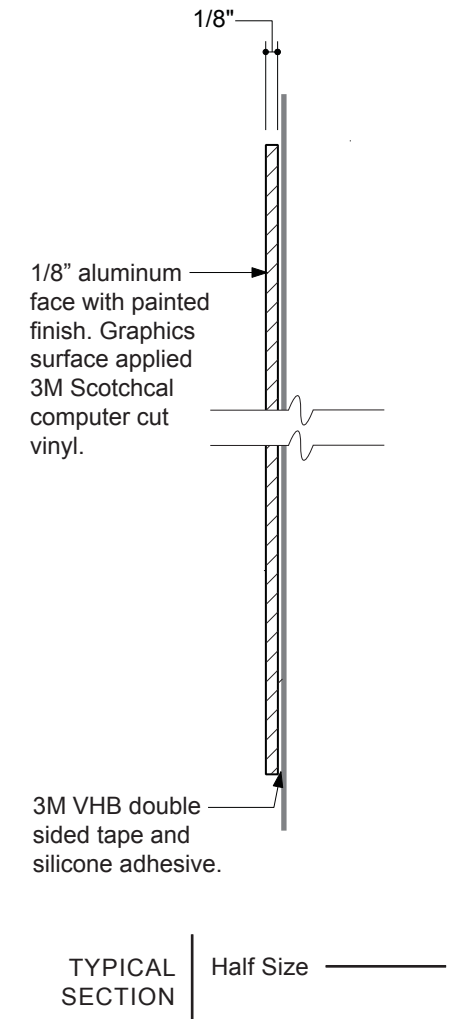

HUNT DESIGN
25 N. MENTOR AVE.
PASADENA, CA 91106

PAGE: 1 of 2
PROJECT: UC RIVERSIDE
SUBJECT: RIVERSIDE, CA
SIGN STRUCTURAL CALCS.
BY: DVM DATE: 10-1-07
P.O.# DWGS. FROM PERRY SHIMOJI

FOR COLUMN & FOOTING DESIGN

AREA -- SIGN TYPES W50.0 & W70.0
A = 5.29' * 2.96' = 15.7 S.F. (TYPE W70.0)

NOTE: SIGN TYPE W50.0 IS SLIGHTLY
SMALLER IN SIZE THAN TYPE W70.0 -
COLUMN & FOOTING DESIGN FOR BOTH
IS O.K. BY INSPECTION

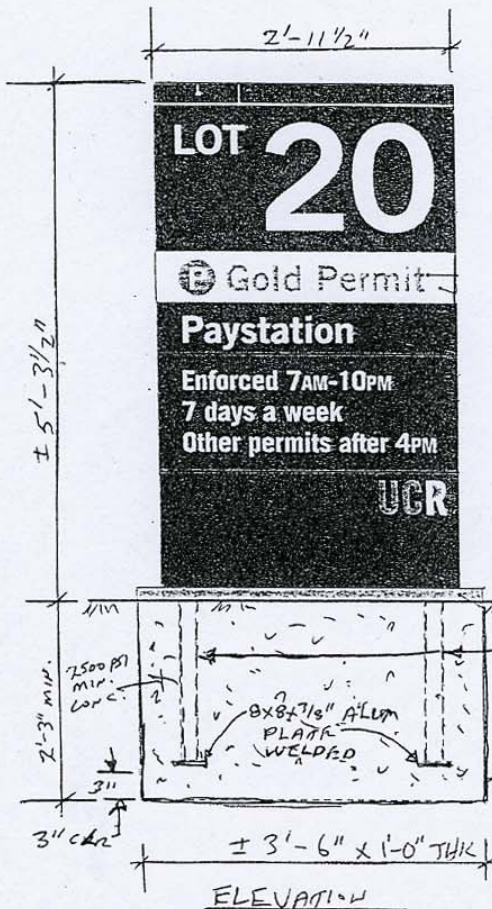

WIND	CBC-'01	80 MPH, EXP. C
CBC-1613	$p=Cq*Ce*Qs*I$	$I=1.0$
$Qs =$	16.4	$Cq = 1.4$
	25.94 LBS/S.F. @ 20'	$Ce = 1.13$
	24.34 LBS/S.F. < 15'	$Ce = 1.06$
S.F.	LBS	FT.
AREA	!PRESS!	X-DIST
15.7	382	2.65
0.0	0	0.00
0.0	0	0.00
0.0	0	0.00

TOTAL 382 2.65 1013 (AVE.)

DOUBLE COLUMN
MOM.'K 0.51

ALUM $F_b = 12$ K/SQ. IN.
 $S = M/F_b$ WIND 1/3 INCR.
 $S = 0.75 * M$ (INCL 1.33 WIND)
 $S = 0.38$ IN³

$S = (bd^3 - b1*d1^3) / (6*d)$
 $d = 2$ $d1 = 1.75$
 $b = 2$ $b1 = 1.75$

USING 2"x2"x 1/8" ALUM. TUBE
 $S = 0.55$ IN³ > 0.38
O.K.

COAT ALUM. SURFACES EMBEDDED IN
CONC. WITH ONE HEAVY COAT OF
ALKALI-RESISTANT BITUMINOUS
(BITUMASTIC) PAINT TO 2" MIN.
ABOVE GRADE

WT. OF SIGN = 175 LBS +/-
AXIAL STRESS IS NEGLIGIBLE

SEE PAGE 2 FOR FOOTING DETAILS



JOB NO. HUNT-144

HUNT DESIGN
25 N. MENTOR AVE.
PASADENA, CA 91106

PAGE: 2 of 2
PROJECT: UC RIVERSIDE
SUBJECT: RIVERSIDE, CA
SIGN STRUCTURAL CALCS.
BY: DVM DATE: 10-1-07
P.O.# DWGS. FROM PERRY SHIMOJI

SINGLE FOOTING - STRAIGHT

DESIGN OF EMBEDDED POLE FOOTINGS

DESCRIPTION	>>	42" WIDE		
	>>	+ 12" THK.		
ALLOW PASSIVE	psf	200	200	200
MAX PASSIVE	psf	1,500	1,500	1,500
LOAD DURATION FACTOR		1.33	1.33	1.33
POINT LOAD	lbs	382	0	0
LOAD HT.	ft	2.65	0.00	0.00
DIST. LOAD	#/ft	0	0	0
START HT.	ft	0.00	0.00	0.00
END HT.	ft	0.00	0.00	0.00
WIDTH/DIAMETER	in	42	0	0
CIRCULAR ?	y/n	N	N	N
RESTRAINED ?	y/n	N	N	N
SUMMARY				
Moments @ Surface:				
Point Load	ft-#	1,012	0	0
Uniform Load	ft-#	0	0	0
... Total Moment	ft-#	1,012	0	0
Total Lateral Load	#	382	0	0
NON-RESTRAINED				
Min. Req'd Embedment				
$A(1+(1+4.36h/A)^{.5})/2$	ft	2'-3"		
$A=2.34P/(S 1 b)$	ft	2.18'	0.00	0.00
Press @ 1/3 Embed.:		DEPTH		
Actual	psf	194	0	0
Allowable	psf	193	0	0
RESTRAINED				
Min. Req'd Embedment				
$(4.25 P h/S3 b)^{.5}$ ft		0.00	0.00	0.00
Pressure @ Bottom				
Actual	psf	0	0	0
Allowable	psf	0	0	0
Surface Restraint Force	lbs	0	0	0

PER CBC TABLE 18-1-A
POLE 2X ALLOWABLE



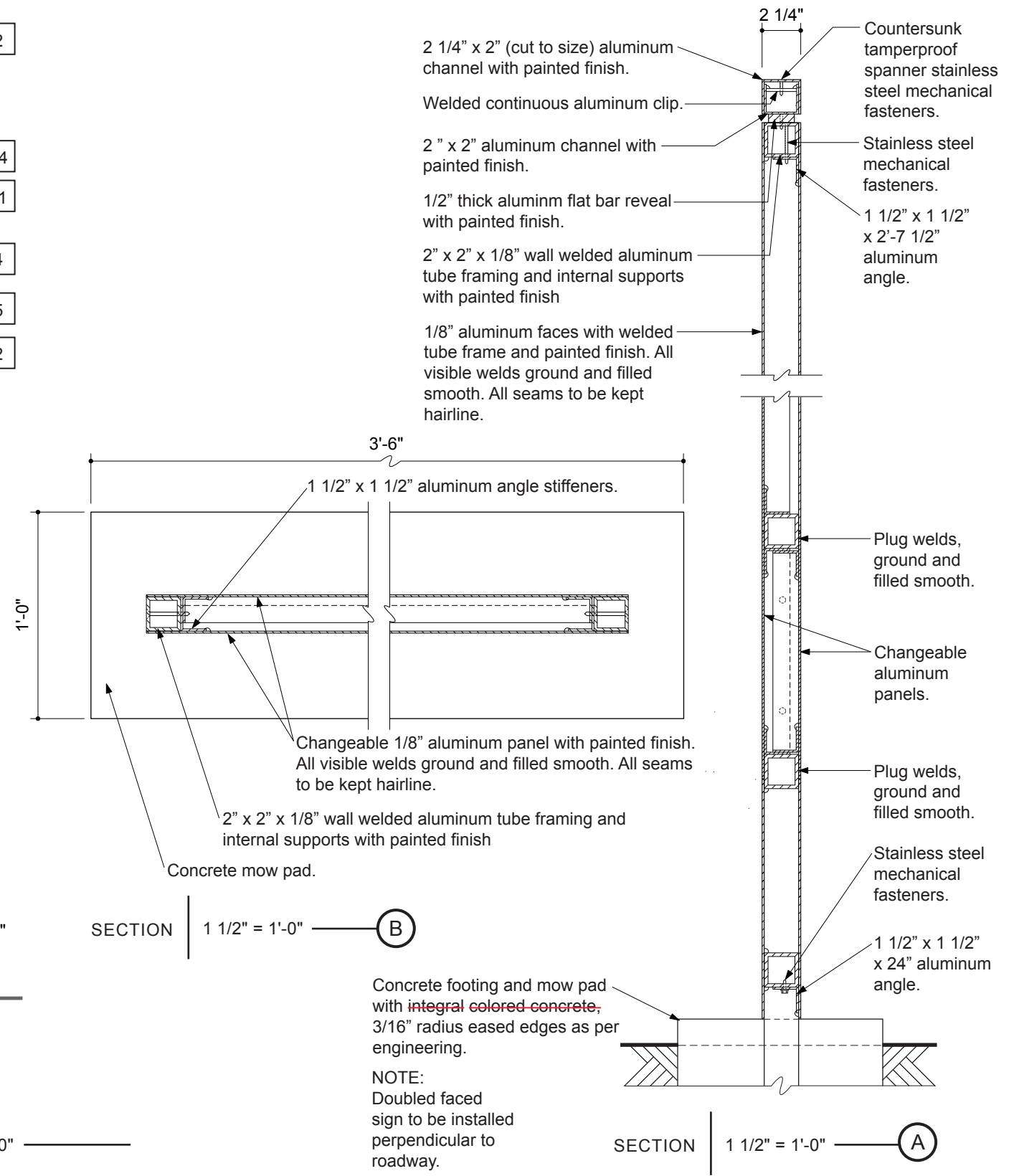
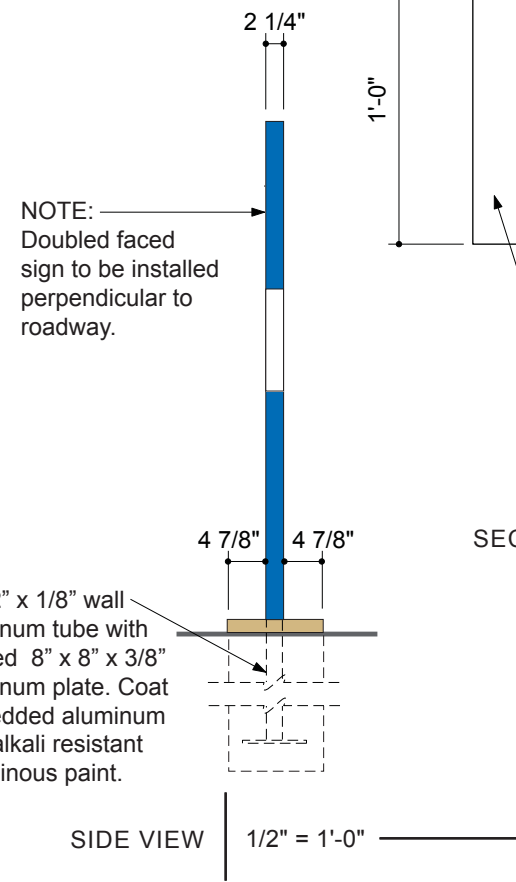
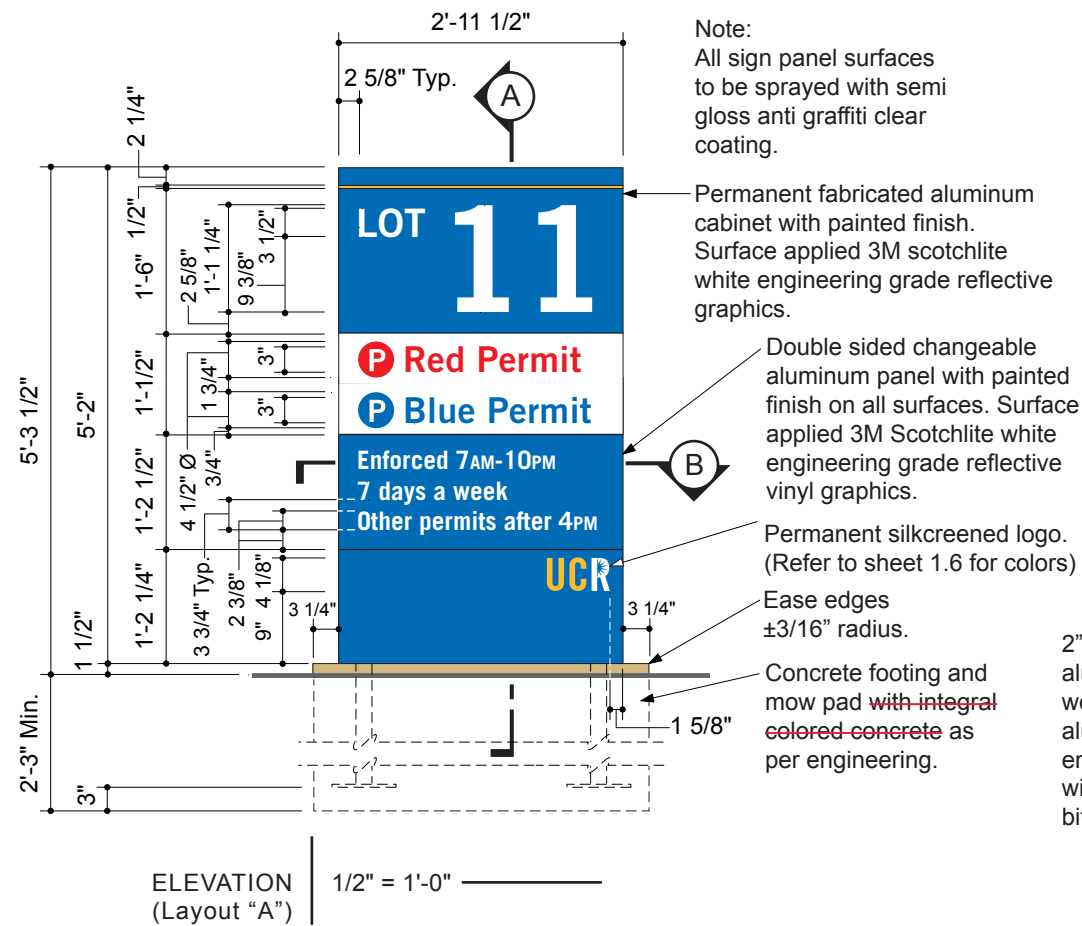
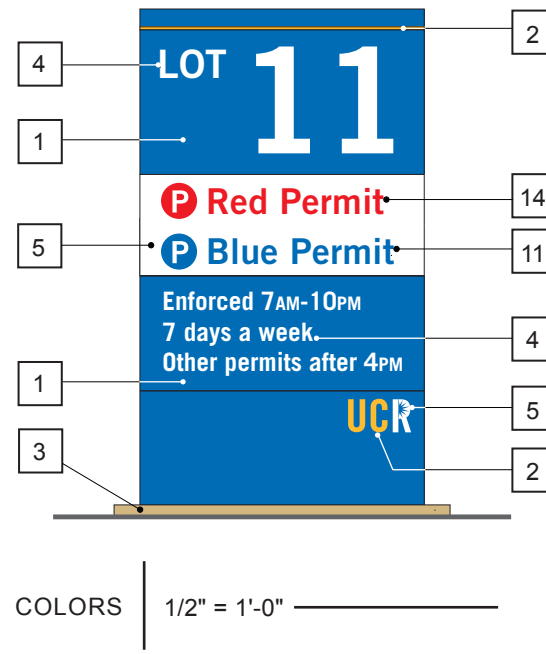
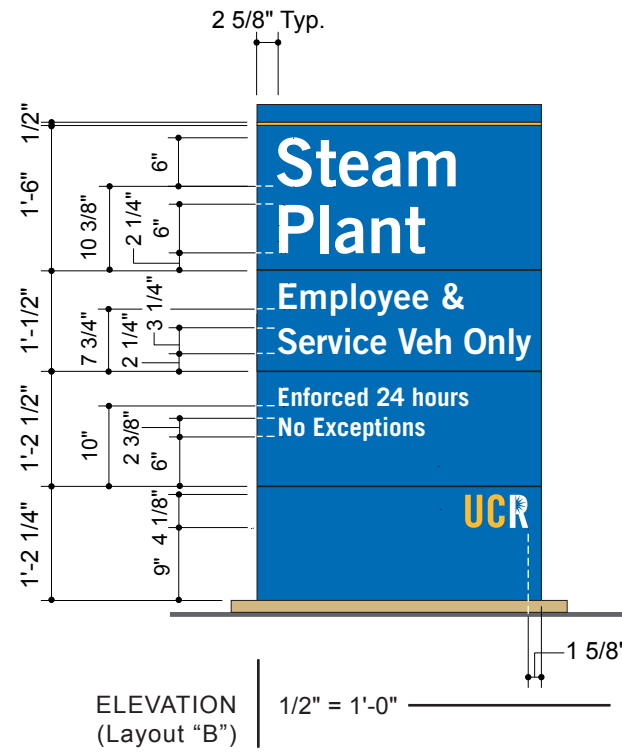

HUNT DESIGN
25 N. MENTOR AVE.
PASADENA, CA 91106

PAGE: 1 of 2
PROJECT: UC RIVERSIDE
SUBJECT: RIVERSIDE, CA
SIGN STRUCTURAL CALCS.
BY: DVM DATE: 10-1-07
P.O.# DWGS. FROM PERRY SHIMOJI

FOR COLUMN & FOOTING DESIGN

AREA -- SIGN TYPES W50.0 & W70.0
A = 5.29' * 2.96' = 15.7 S.F. (TYPE W70.0)

NOTE: SIGN TYPE W50.0 IS SLIGHTLY
SMALLER IN SIZE THAN TYPE W70.0 -
COLUMN & FOOTING DESIGN FOR BOTH
IS O.K. BY INSPECTION

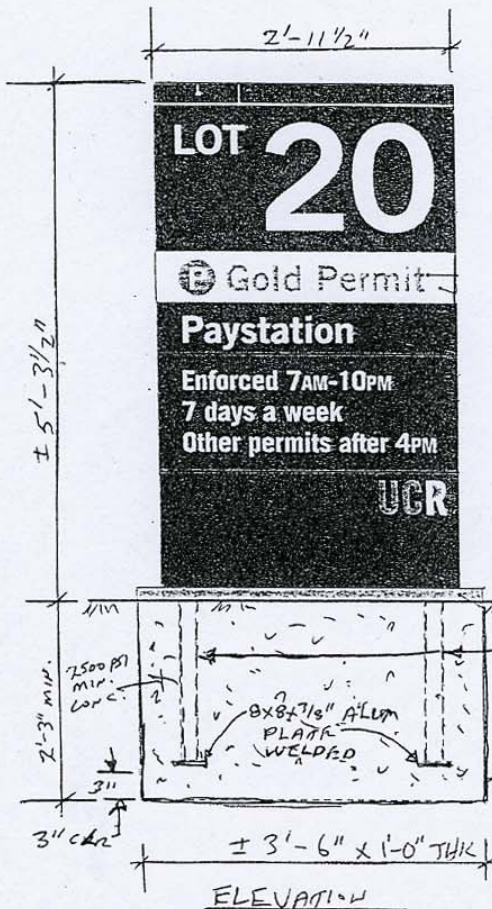

WIND	CBC-'01	80 MPH, EXP. C
CBC-1613	$p=Cq \cdot Ce \cdot Qs \cdot I$	$I=1.0$
$Qs =$	16.4	$Cq = 1.4$
	25.94 LBS/S.F. @ 20'	$Ce = 1.13$
	24.34 LBS/S.F. < 15'	$Ce = 1.06$
S.F.	LBS	FT.
AREA	!PRESS!	X-DIST
15.7	382	2.65
0.0	0	0.00
0.0	0	0.00
0.0	0	0.00

TOTAL	382	2.65	1013
		(AVE.)	
DOUBLE COLUMN			
MOM. 'K	0.51		

ALUM $F_b = 12$ K/SQ. IN.
 $S = M/F_b$ WIND 1/3 INCR.
 $S = 0.75 \cdot M$ (INCL 1.33 WIND)
 $S = 0.38$ IN³

$S = (bd^3 - b1 \cdot d1^3) / (6 \cdot d)$
 $d = 2$ $d1 = 1.75$
 $b = 2$ $b1 = 1.75$

USING 2"x2"x 1/8" ALUM. TUBE
 $S = 0.55$ IN³ > 0.38
O.K.

COAT ALUM. SURFACES EMBEDDED IN
CONC. WITH ONE HEAVY COAT OF
ALKALI-RESISTANT BITUMINOUS
(BITUMASTIC) PAINT TO 2" MIN.
ABOVE GRADE

WT. OF SIGN = 175 LBS +/-
AXIAL STRESS IS NEGLIGIBLE

SEE PAGE 2 FOR FOOTING DETAILS



JOB NO. HUNT-144

HUNT DESIGN
25 N. MENTOR AVE.
PASADENA, CA 91106

PAGE: 2 of 2
PROJECT: UC RIVERSIDE
SUBJECT: RIVERSIDE, CA
SIGN STRUCTURAL CALCS.
BY: DVM DATE: 10-1-07
P.O.# DWGS. FROM PERRY SHIMOJI

SINGLE FOOTING - STRAIGHT

DESIGN OF EMBEDDED POLE FOOTINGS

DESCRIPTION	>>	42" WIDE		
	>>	+ 12" THK.		
ALLOW PASSIVE	psf	200	200	200
MAX PASSIVE	psf	1,500	1,500	1,500
LOAD DURATION FACTOR		1.33	1.33	1.33
POINT LOAD	lbs	382	0	0
LOAD HT.	ft	2.65	0.00	0.00
DIST. LOAD	#/ft	0	0	0
START HT.	ft	0.00	0.00	0.00
END HT.	ft	0.00	0.00	0.00
WIDTH/DIAMETER	in	42	0	0
CIRCULAR ?	y/n	N	N	N
RESTRAINED ?	y/n	N	N	N
SUMMARY				
Moments @ Surface:				
Point Load	ft-#	1,012	0	0
Uniform Load	ft-#	0	0	0
... Total Moment	ft-#	1,012	0	0
Total Lateral Load	#	382	0	0
NON-RESTRAINED				
Min. Req'd Embedment		2'-3"		
$A(1+(1+4.36h/A)^{.5})/2$	ft	2.18'	0.00	0.00
$A=2.34P/(S \cdot 1 \cdot b)$				
Press @ 1/3 Embed.:				
Actual	psf	194	0	0
Allowable	psf	193	0	0
RESTRAINED				
Min. Req'd Embedment		0.00	0.00	0.00
$(4.25 P h / S3 b)^{.5}$	ft			
Pressure @ Bottom				
Actual	psf	0	0	0
Allowable	psf	0	0	0
Surface Restraint				
Force	lbs	0	0	0

PER CBC TABLE 18-1-A
POLE 2X ALLOWABLE



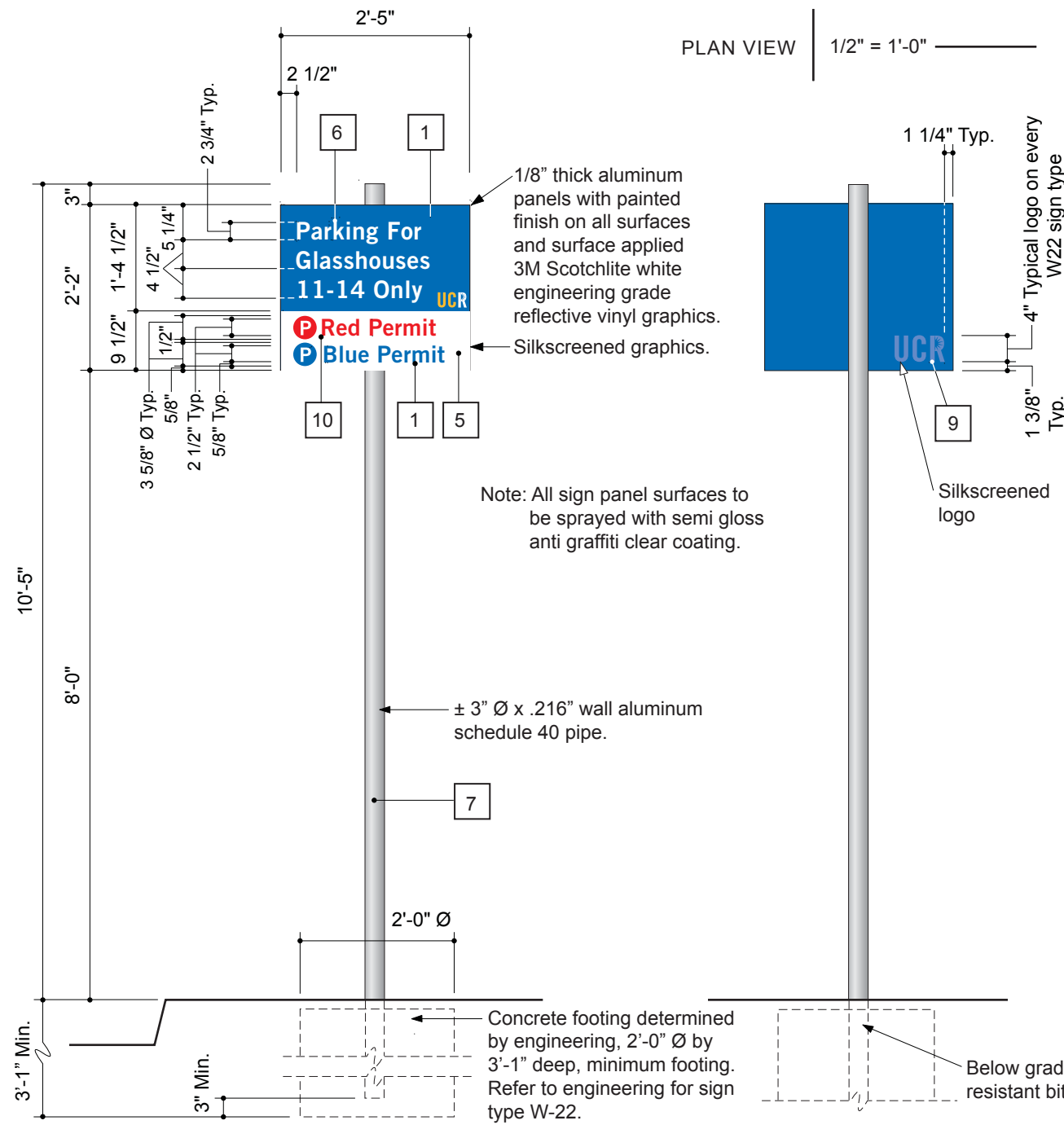

ELEVATION (NEW POLE) | 1/2" = 1'-0"

BACK VIEW | 1/2" = 1'-0"

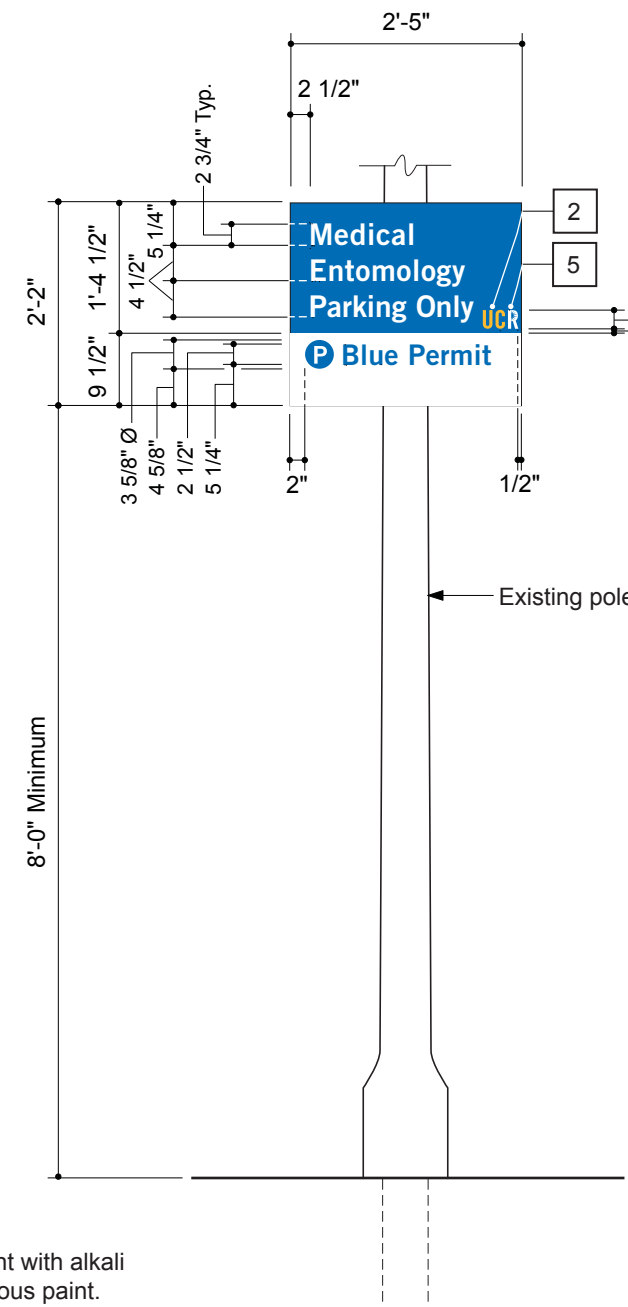

ELEVATION (EXISTING POLE) | 1/2" = 1'-0"

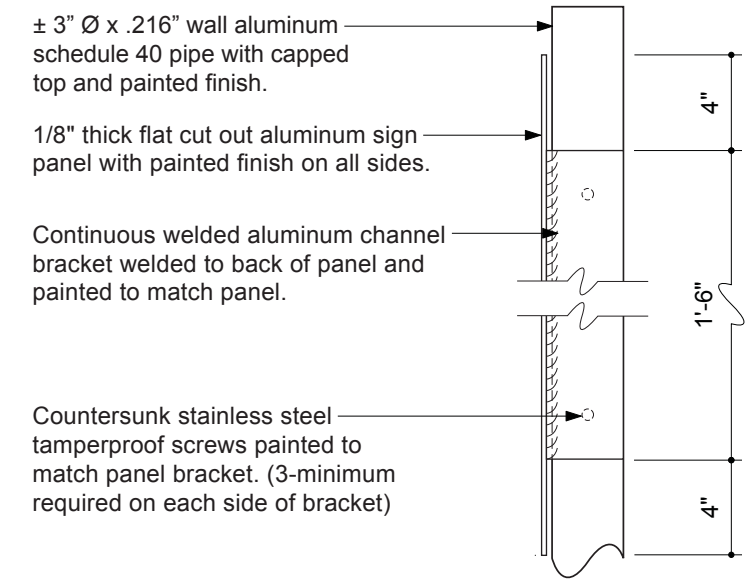

NEW POLE DETAIL | 1 1/2" = 1'-0"

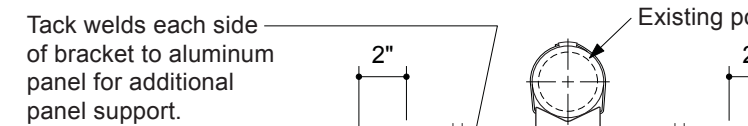

EXISTING POLE PLAN DETAIL | 1 1/2" = 1'-0"

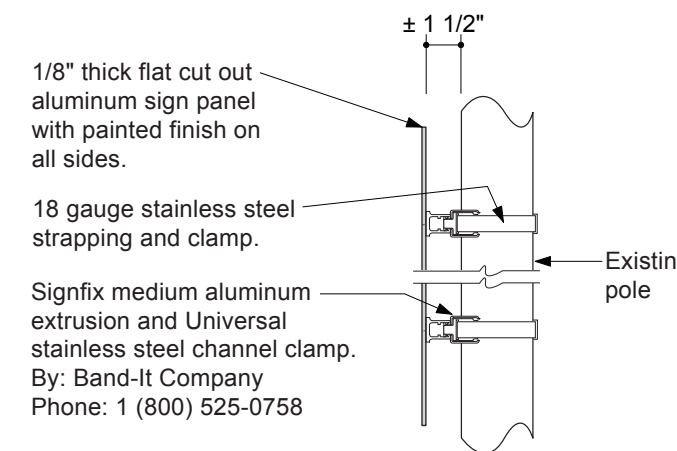

EXISTING POLE DETAIL | 1 1/2" = 1'-0"

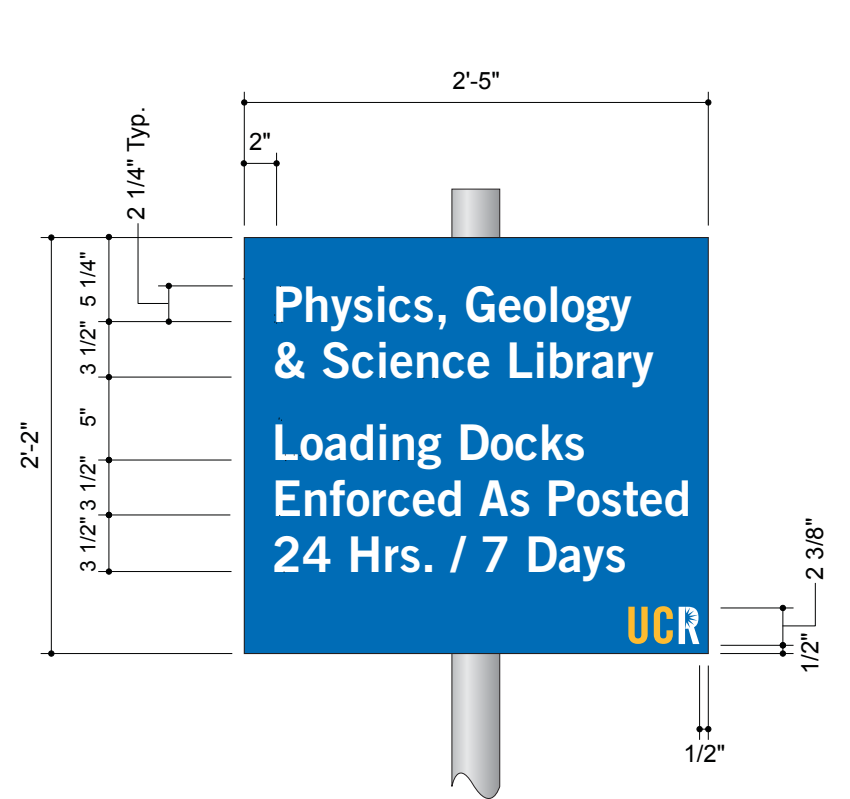

5-LINE CONDITION | 1" = 1'-0"

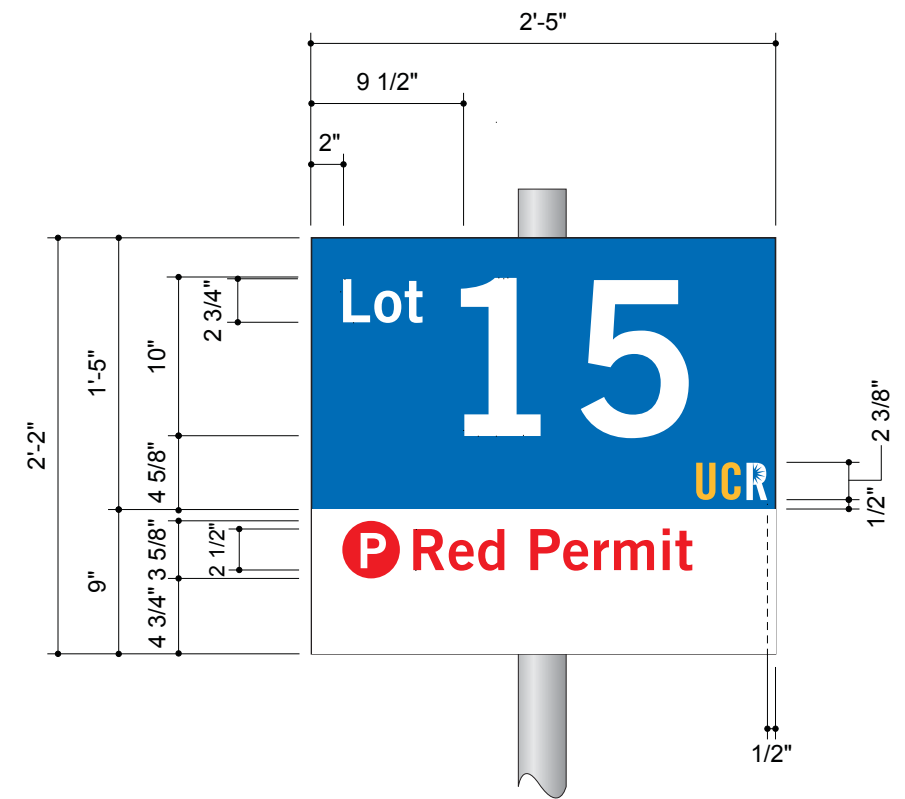

2-LINE CONDITION W/ LARGE NUMERAL | 1" = 1'-0"

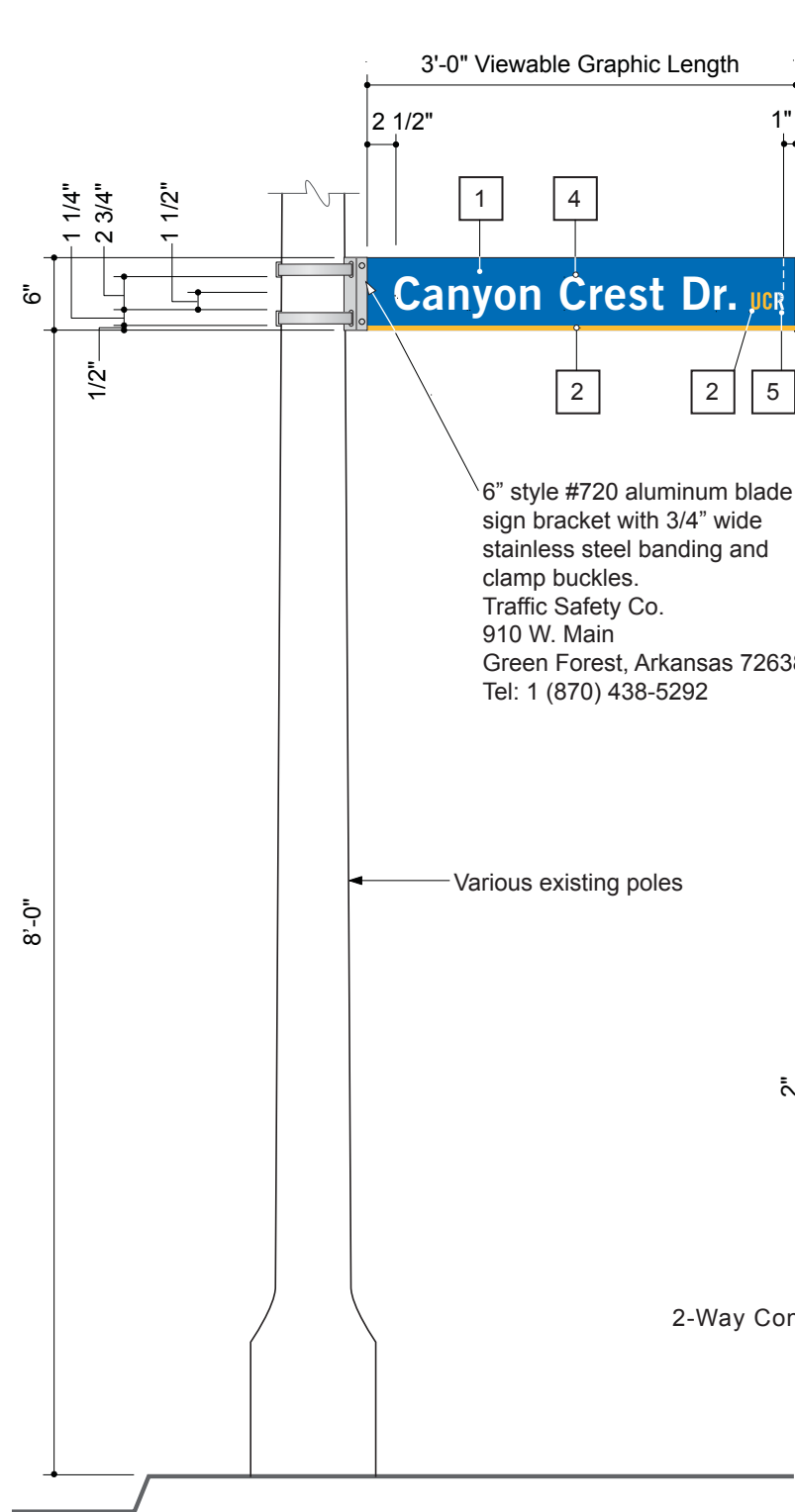

ELEVATION 1-Way Condition | 3/4" = 1'-0"

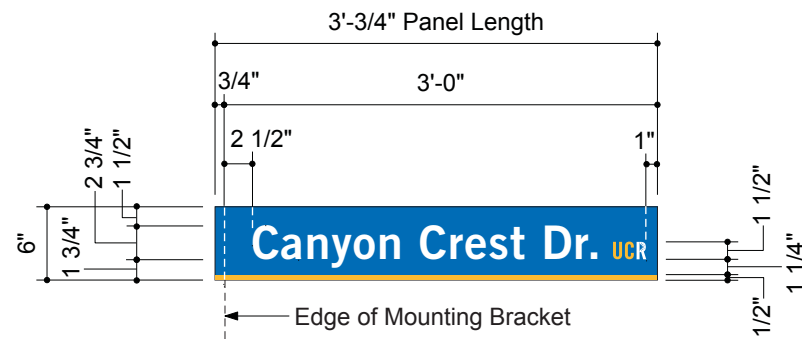

TYPICAL PANEL | 3/4" = 1'-0"

Note: All sign panel surfaces to be sprayed with semi gloss anti graffiti clear coating.

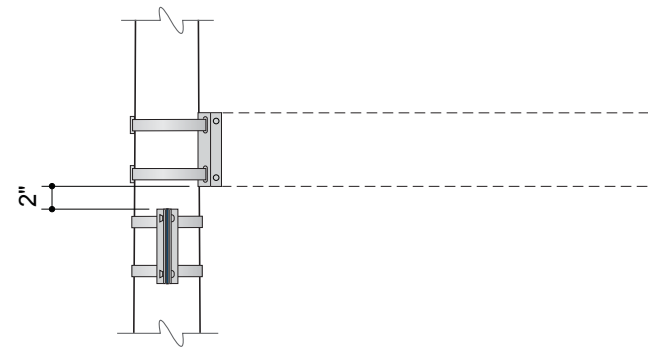

2-Way Condition | 3/4" = 1'-0"

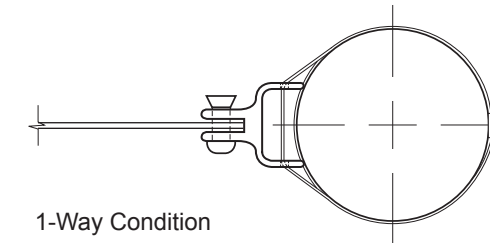
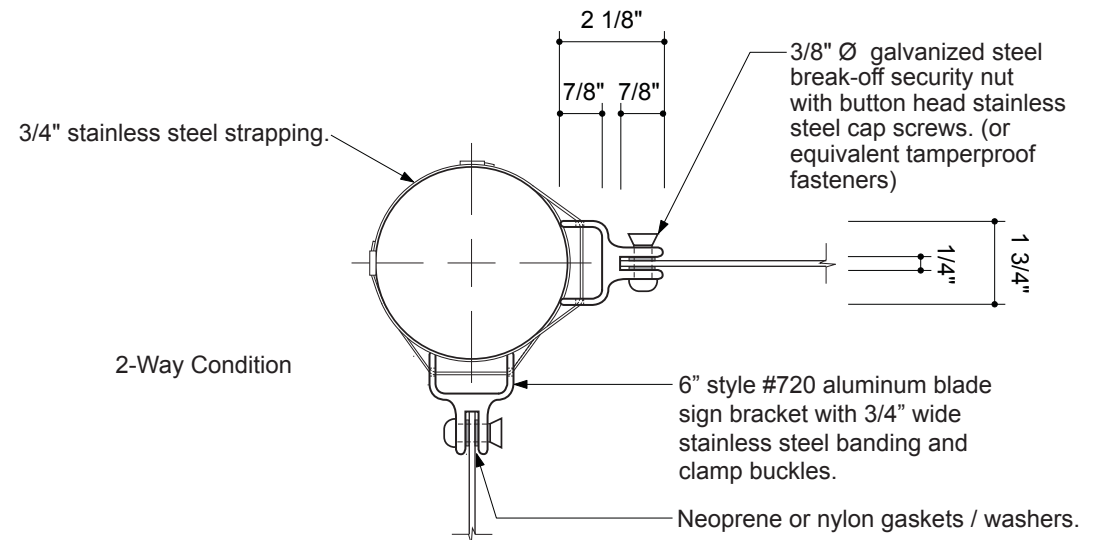
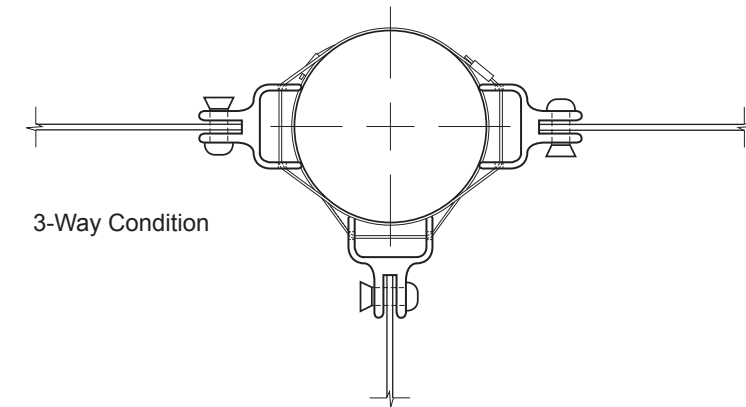

PLAN VIEWS | 3" = 1'-0"

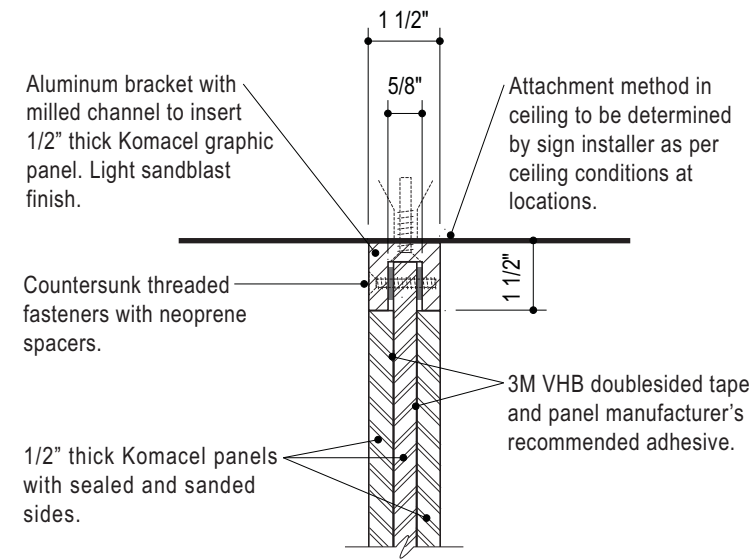

(A) SECTION | 3"=1'-0"

GENERAL NOTES:

1. Copy shown as typical layouts only, actual layouts to be determined and or verified prior to fabrication.
2. Sign installer to verify existing mounting conditions and use appropriate attachment method as per condition.

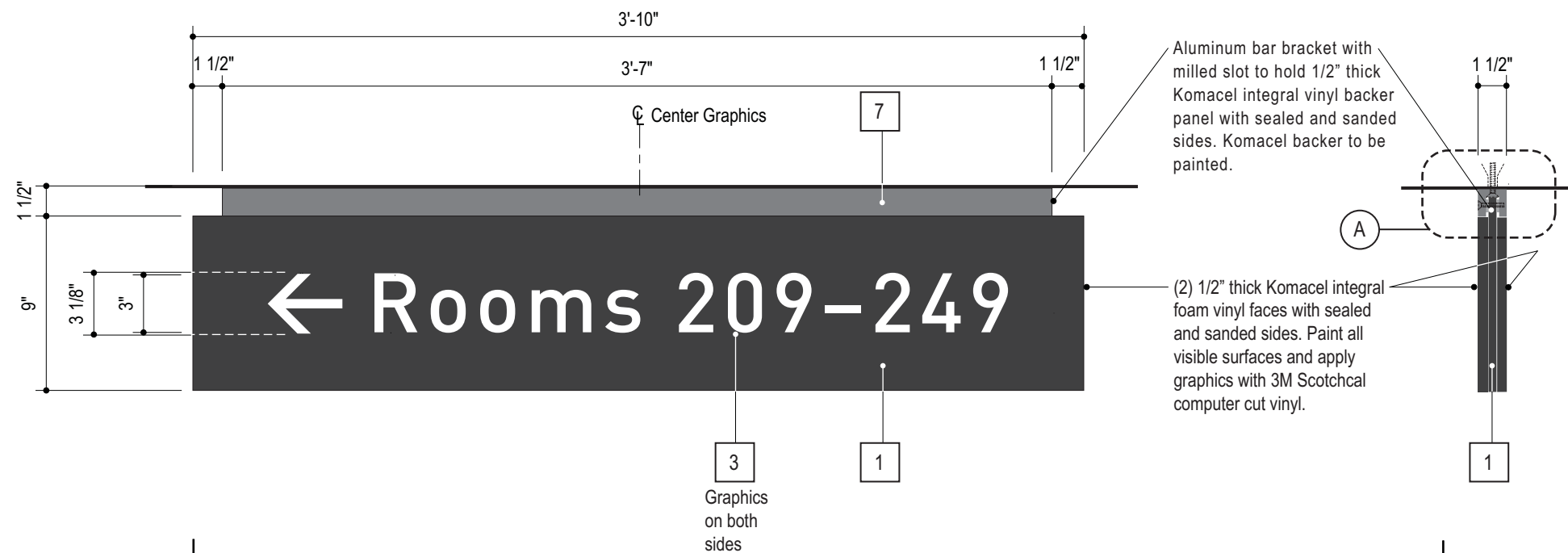

ELEVATION | 1 1/2"=1'-0"

SIDE VIEW | 1 1/2"=1'-0"

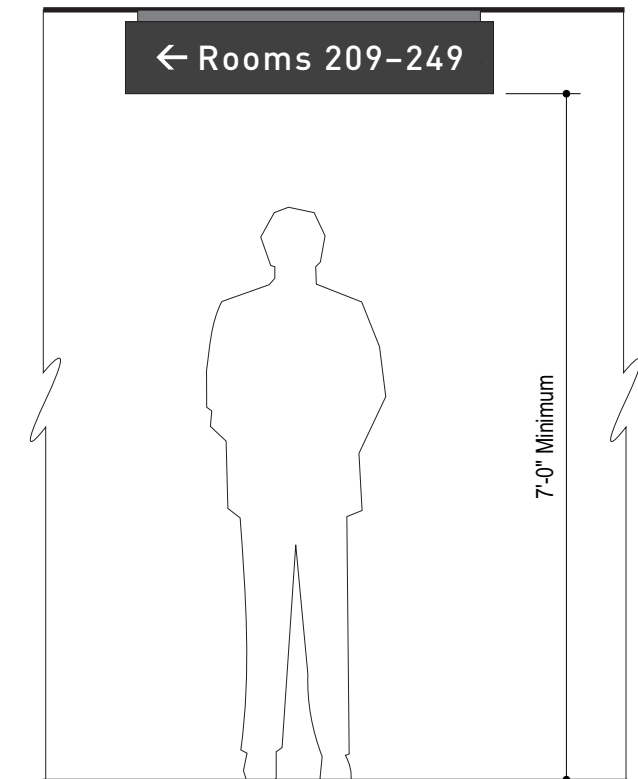

LOCATION ELEVATION | 1/2"=1'-0"

INTERIOR SIGNAGE
 interior locations, there is some latitude on the panel color and material. See MRB submittal as an example. Consult with Campus Architect.

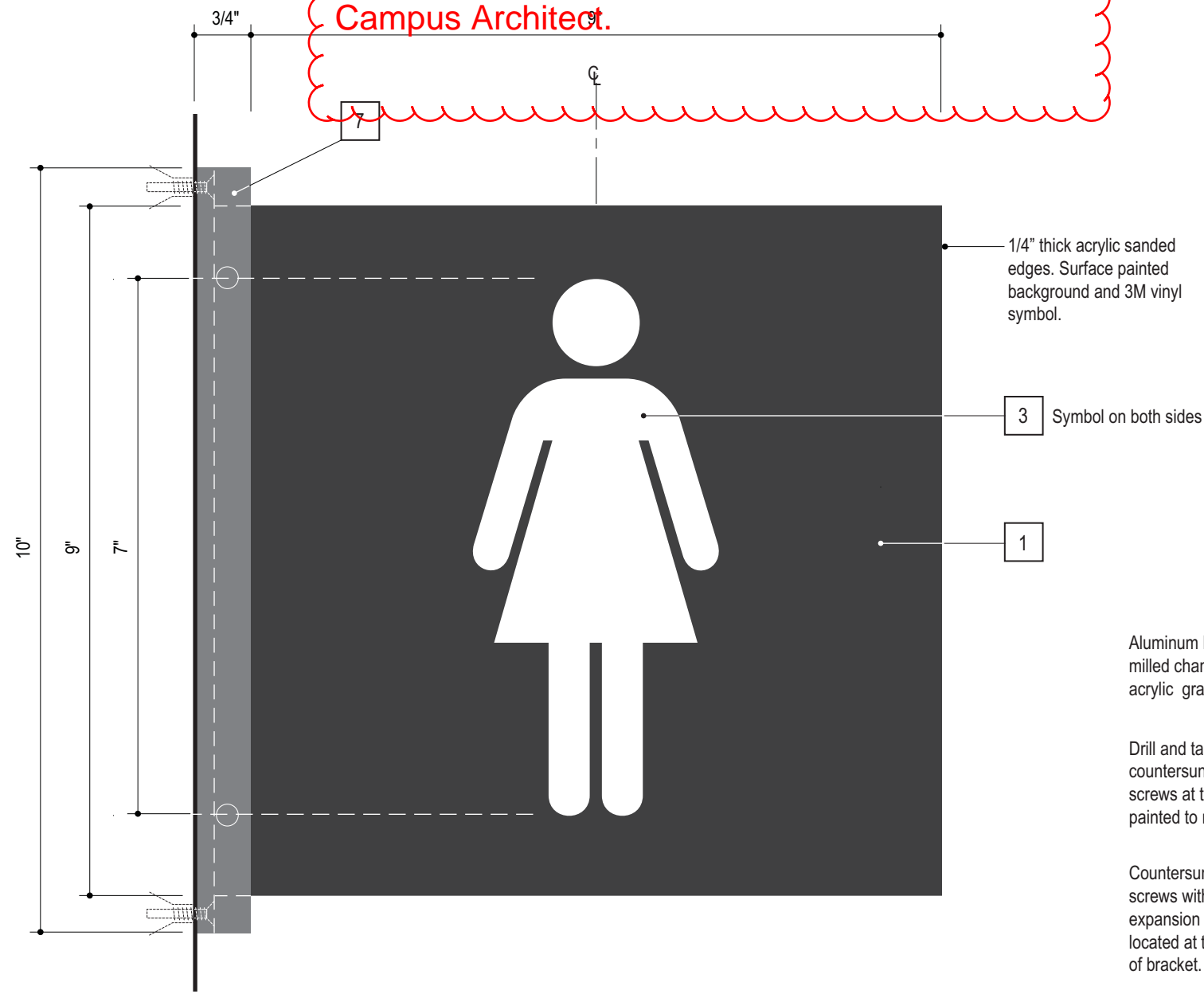

ELEVATION | HALF SIZE

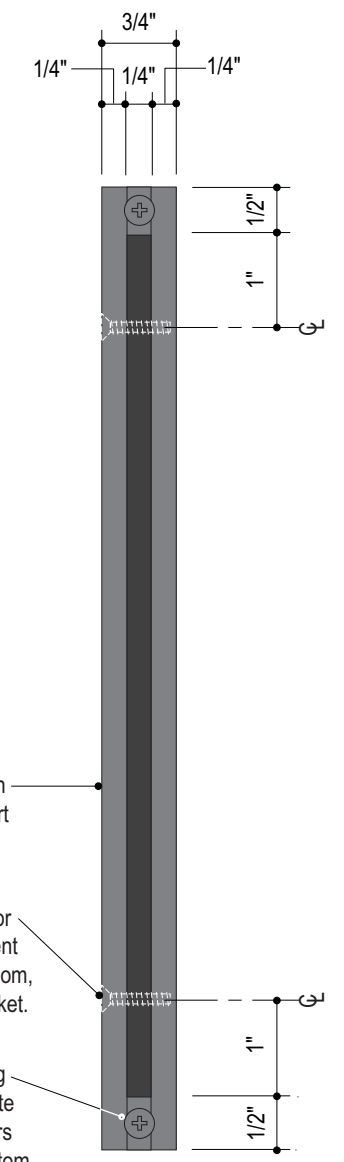

SIDE VIEW | HALF SIZE

- GENERAL NOTES:
1. Copy shown as typical layouts only, actual layouts to be determined and or verified prior to fabrication.
 2. Sign installer to verify existing mounting conditions and use appropriate attachment method as per condition.

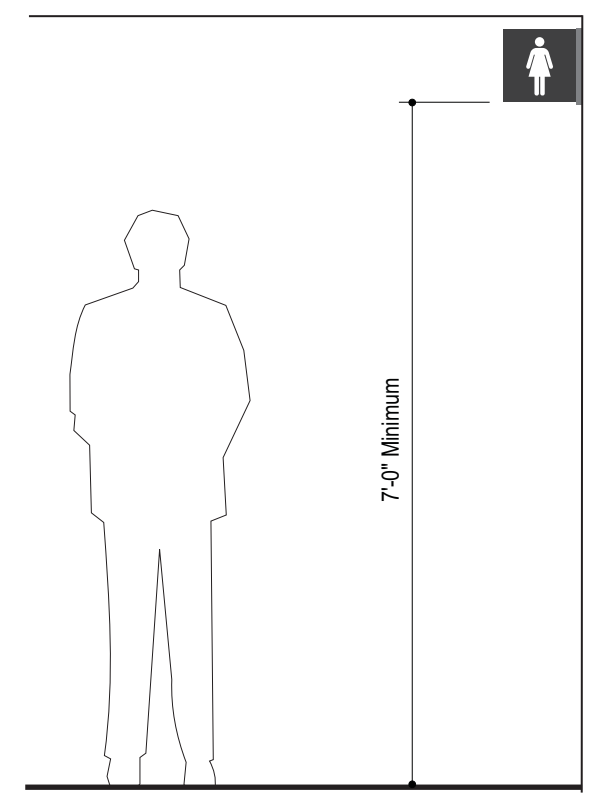

LOCATION ELEVATION | 1/2"=1'-0"

GENERAL NOTES:

1. Copy shown as typical layouts only, actual layouts to be determined and or verified prior to fabrication.
2. Sign installer to verify existing mounting conditions and use appropriate attachment method as per condition.
3. Braille shall be Calif Grade 2 (Contracted Braille).
4. An inverted "L" shall precede all numbers in Braille.

INTERIOR SIGNAGE
 interior locations, there is some latitude on the panel color and material. See MRB submittal as an example. Consult with Campus Architect.

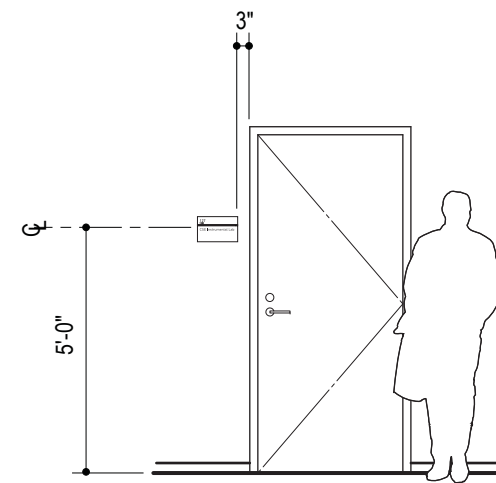

LOCATION ELEVATION | 1/4"=1'-0"

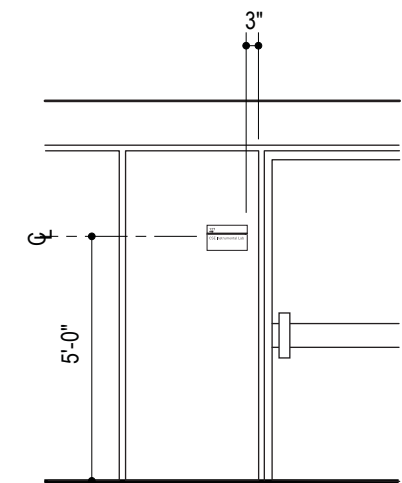

ALTERNATE GLASS MOUNTING | 1/4"=1'-0"

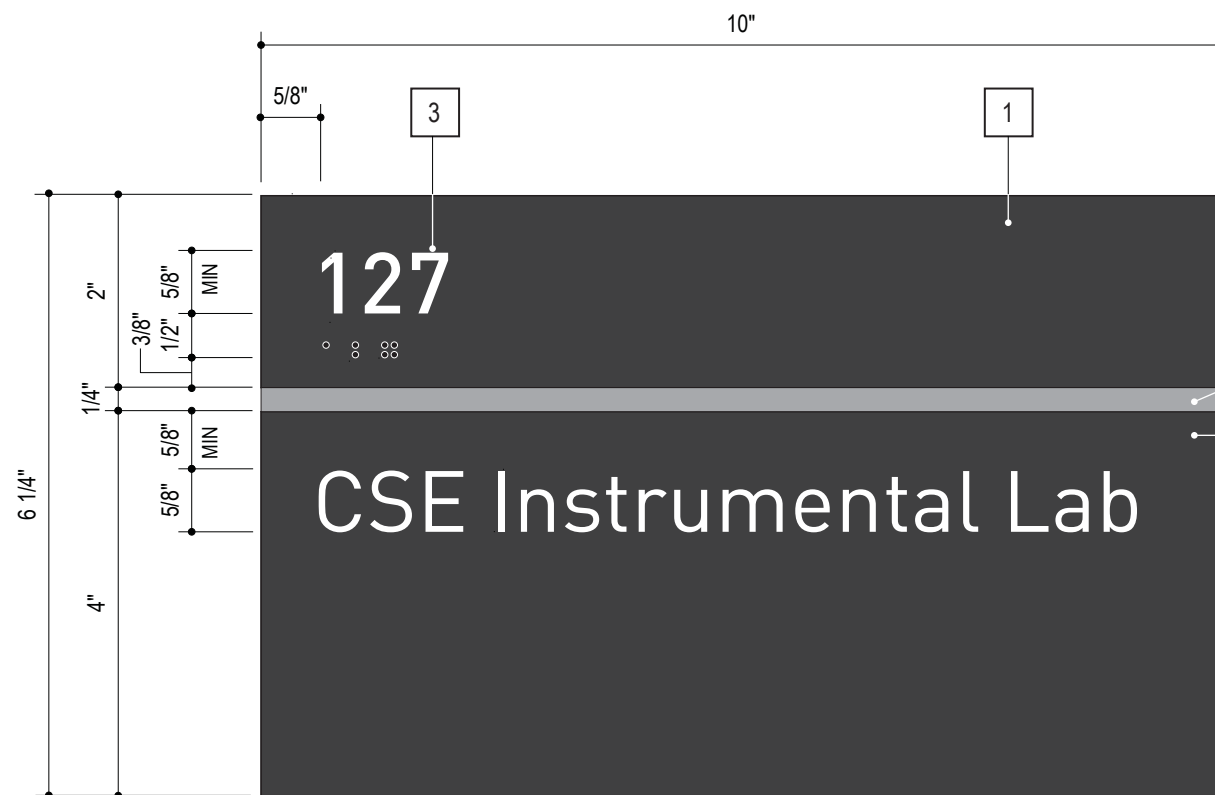

ELEVATION | HALF SIZE

1/4" thick photopolymer etched panel with 1/32" raised copy, California grade 2 braille.

1/4" x 1/4" square aluminum bar raised 1/8" above etched background and eased edges. Attached with concealed fasteners threaded and taped from back light sandblast finish.

Separate changeable bottom panel 1/16" thick New Hermes Gravoply II panel laminated to 1/8" acrylic panel. Copy to be engraved and panel sides to be painted to match slate gray.

1/16" thick acrylic backer panel permanently mounted to wall with 3M VHB tape and silicone. Paint sides to match adjacent sides.

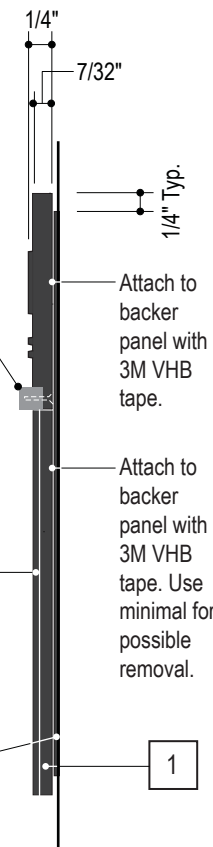

SIDE VIEW | HALF SIZE

Separate changeable bottom panel 1/16" thick New Hermes Gravoply II panel laminated to 1/8" acrylic panel. Copy to be engraved and panel sides to be painted to match slate gray.

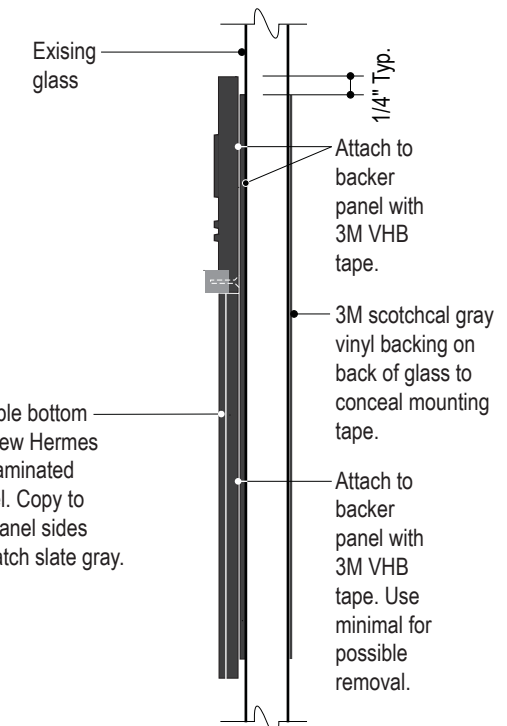

SIDE VIEW (GLASS MOUNT) | HALF SIZE

Updated 11/02/09

GENERAL NOTES:

- 1. Copy shown as typical layouts only, actual layouts to be determined and or verified prior to fabrication.
- 2. Sign installer to verify existing mounting conditions and use appropriate attachment method as per condition.
- 3. Braille shall be Calif Grade 2 (Contracted Braille)
- 4. An inverted "L" shall precede all numbers in Braille.

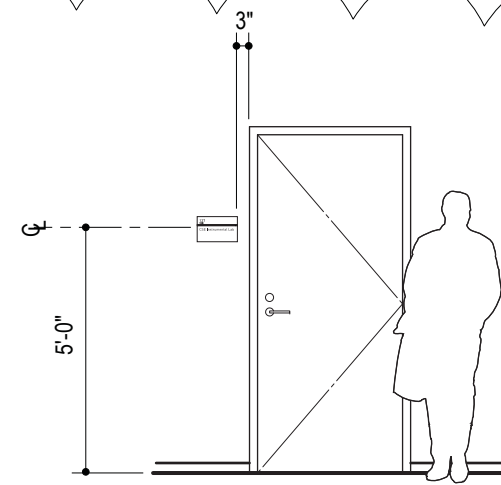

LOCATION ELEVATION | 1/4"=1'-0"

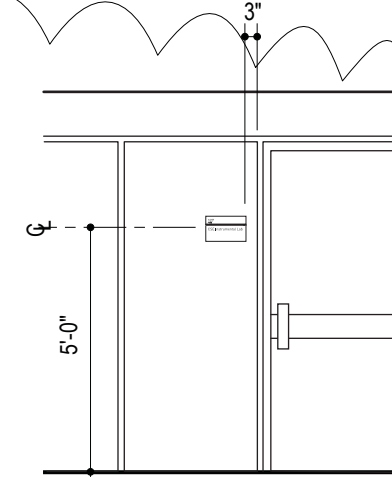

ALTERNATE GLASS MOUNTING | 1/4"=1'-0"

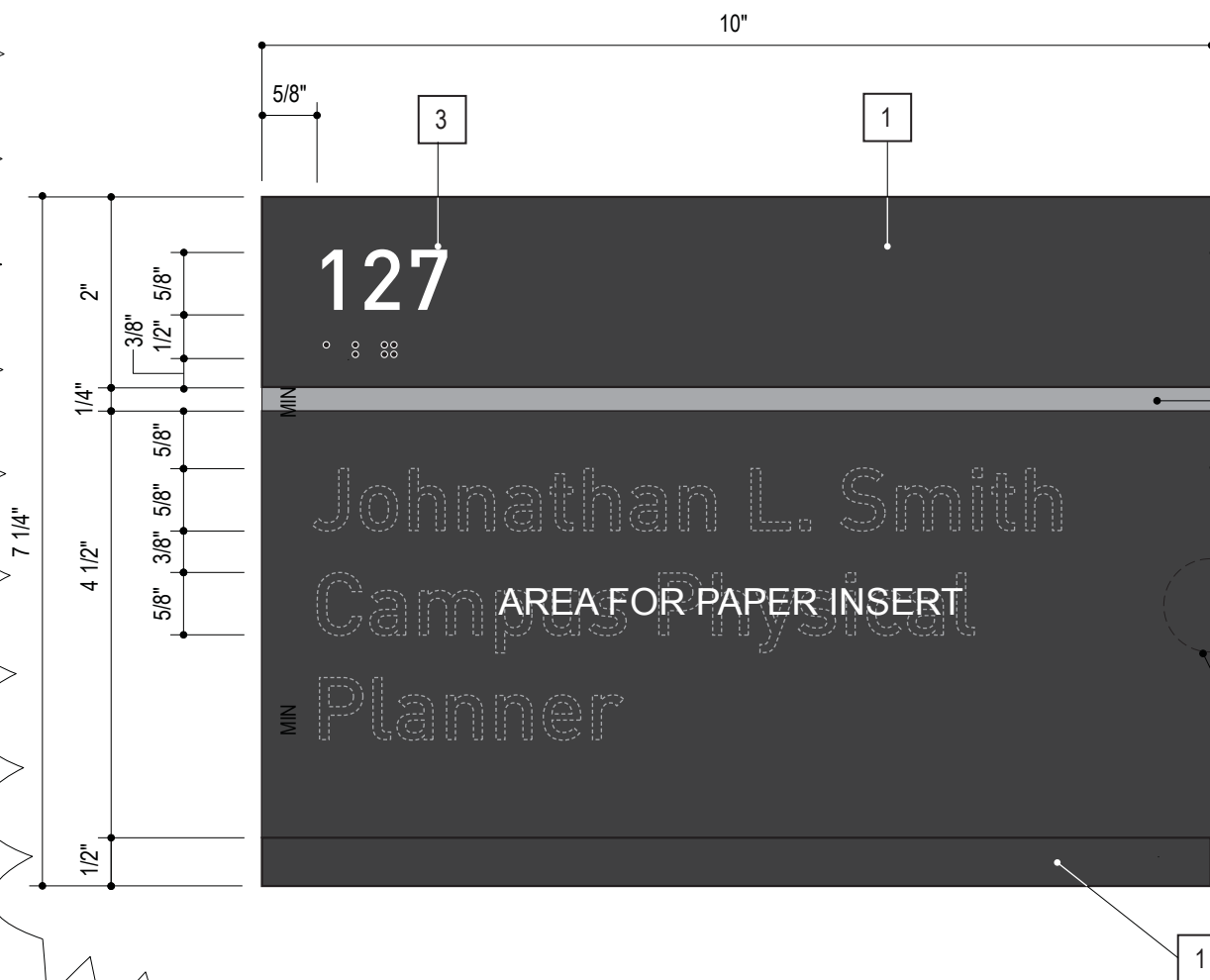

ELEVATION | HALF SIZE

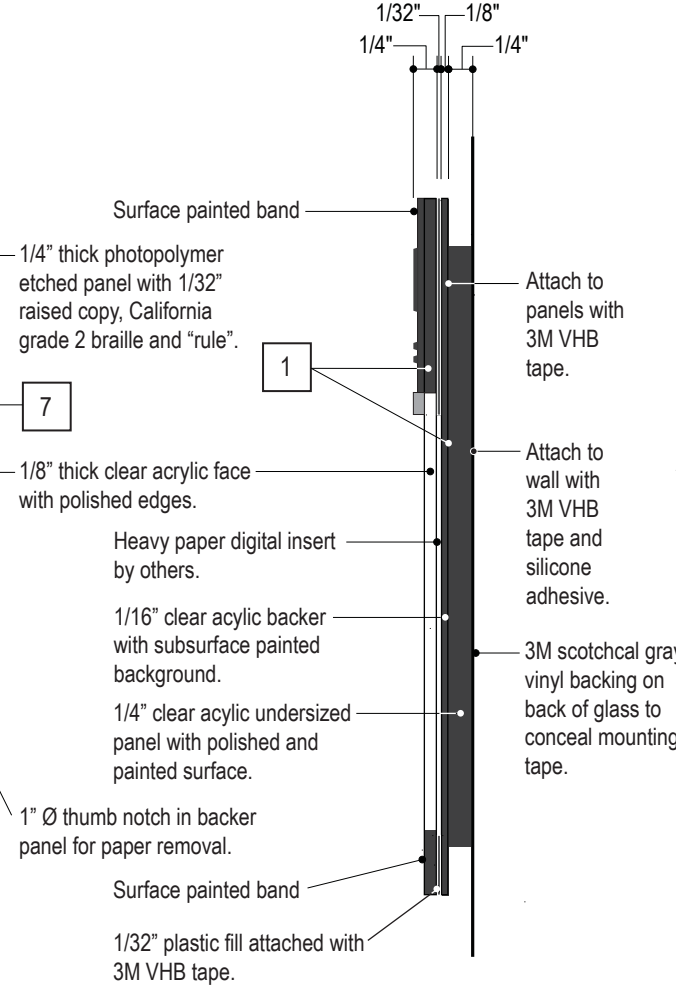

SIDE VIEW | HALF SIZE

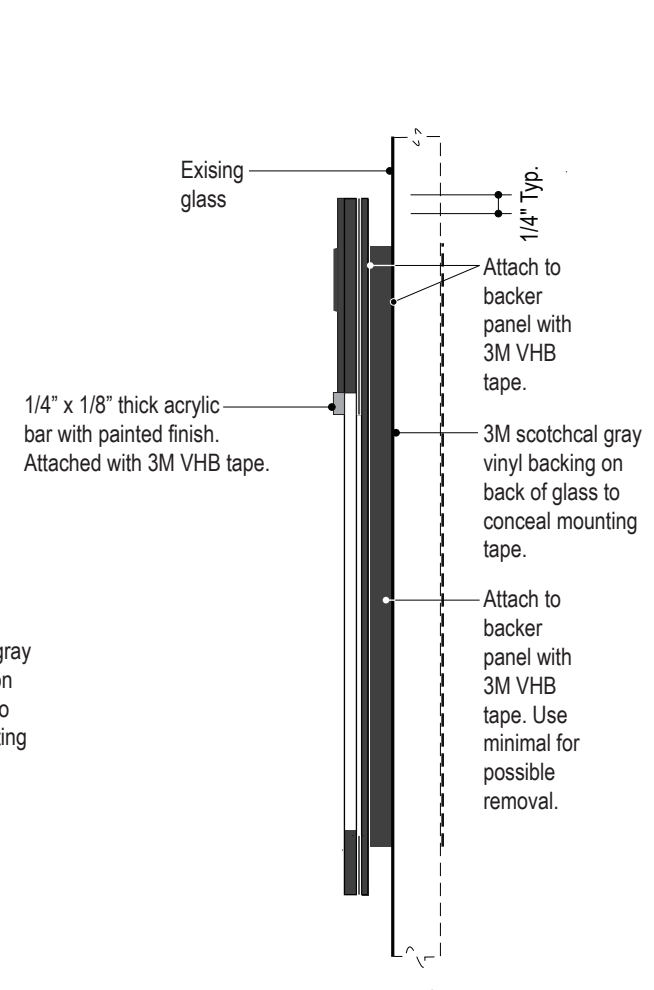

SIDE VIEW (GLASS MOUNT) | HALF SIZE

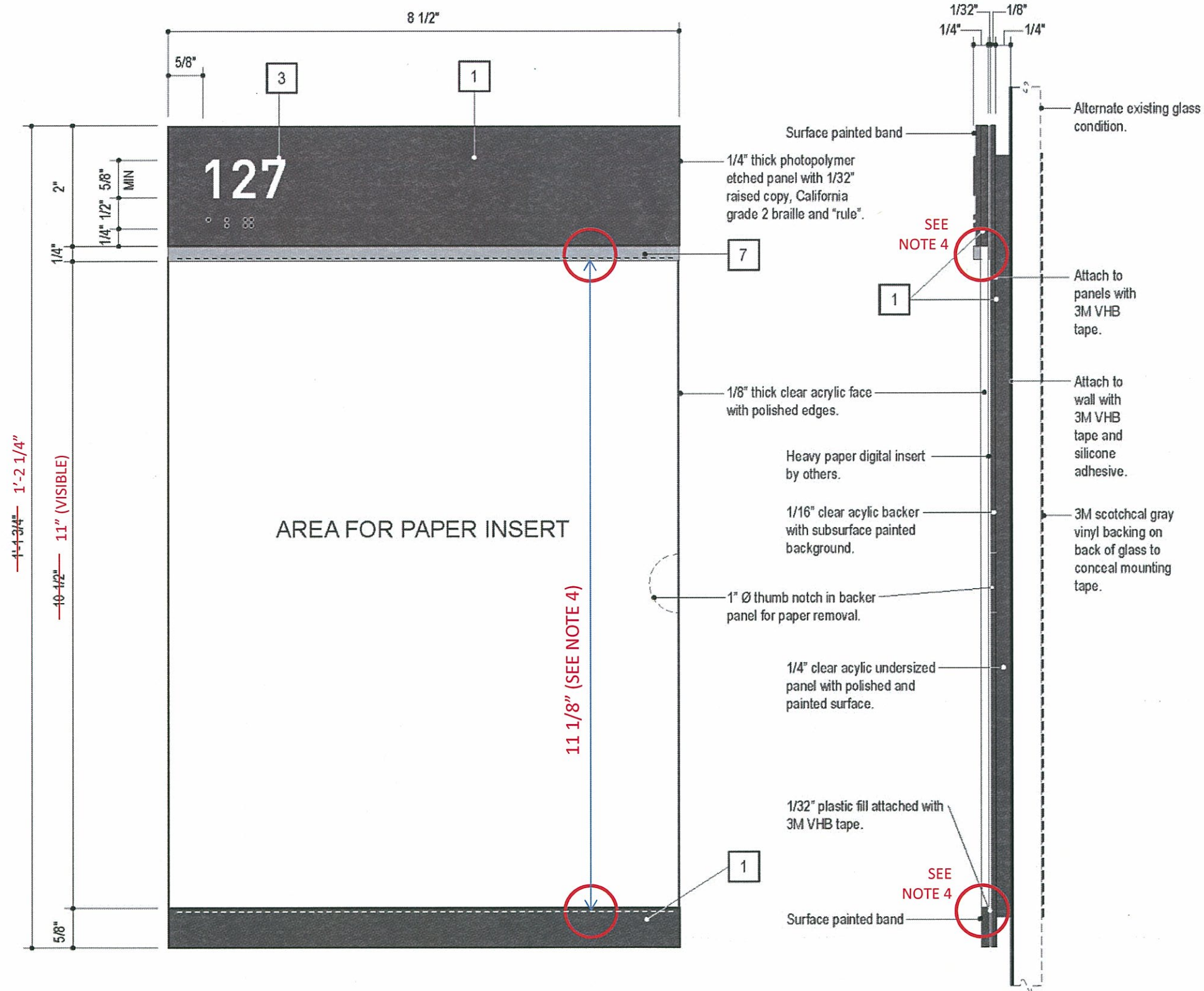

ELEVATION HALF SIZE

SIDE VIEW HALF SIZE

GENERAL NOTES:

1. Copy shown as typical layouts only, actual layouts to be determined and or verified prior to fabrication.
2. Sign installer to verify existing mounting conditions and use appropriate attachment method as per condition.
3. Braille shall be Calif Grade 2 (Contracted Braille).
4. 1/16" tolerance provided at top and bottom for paper insert

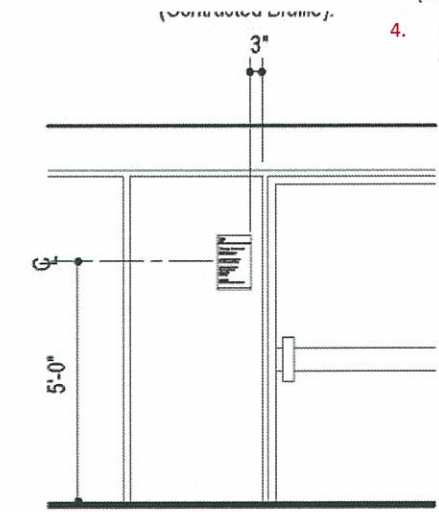

ALTERNATE GLASS MOUNTING 1/4"=1'-0"

5. An inverted "L" shall precede all numbers in Braille.

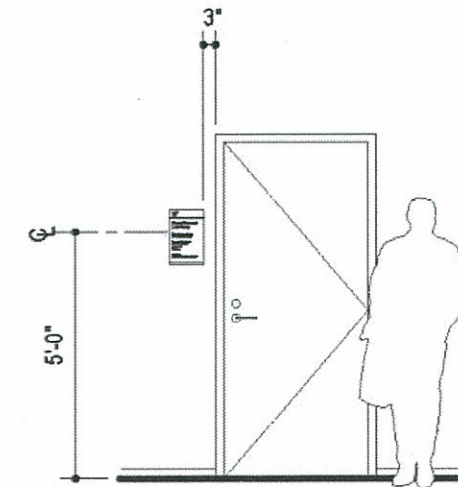

LOCATION ELEVATION 1/4"=1'-0"

CORRECTION TO CAMPUS SIGN PROGRAM
DRAWING 1.63X (REPLACES DRAWING 1.63)

AUTHORIZED BY:

Timothy Ralston
JULY 12, 2011

TIMOTHY RALSTON
ASSOCIATE VICE CHANCELLOR
CAPITAL RESOURCE MANAGEMENT
UNIVERSITY OF CALIFORNIA, RIVERSIDE

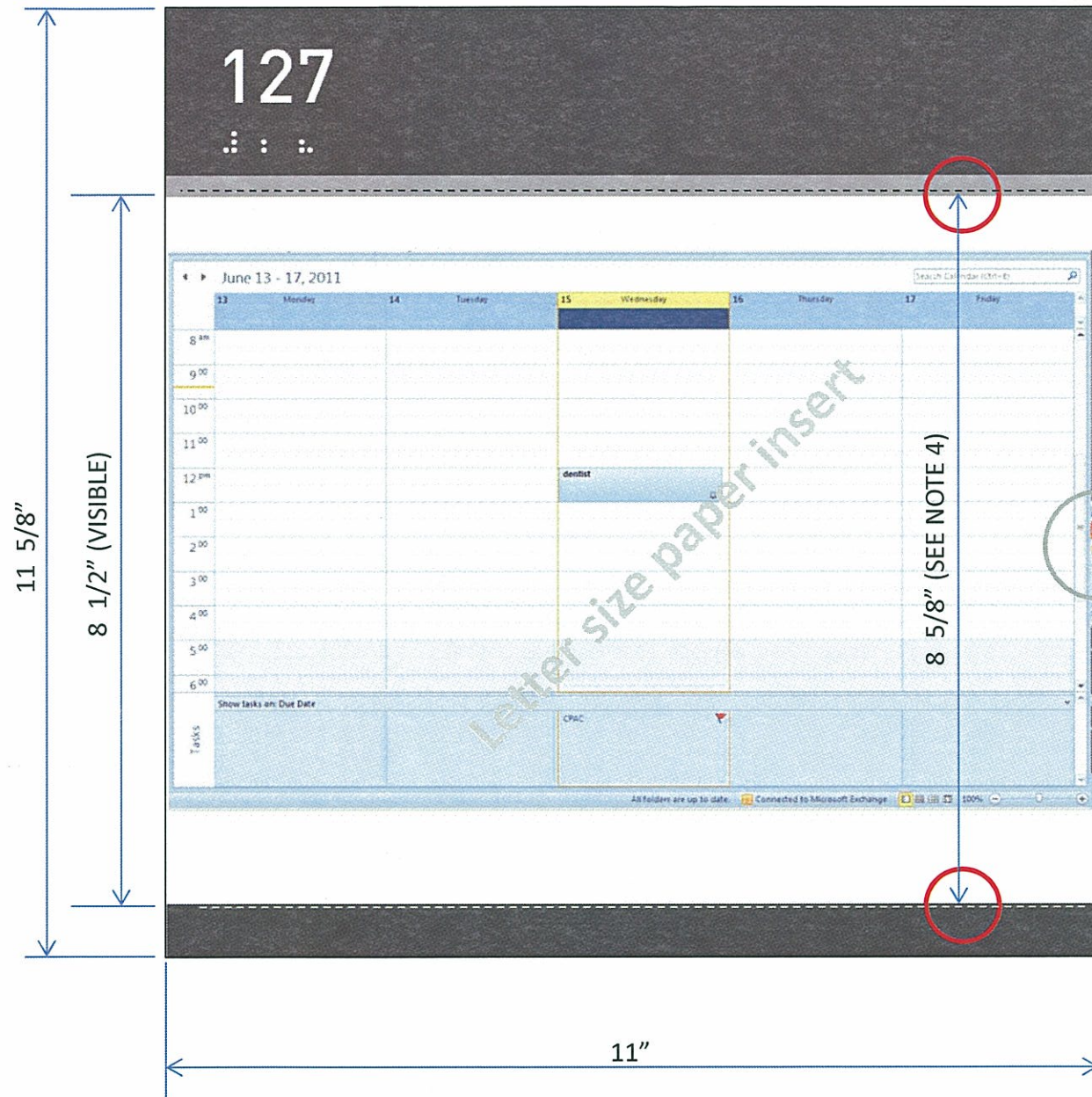

GENERAL NOTES:

1. This sign is to be fabricated identical to sign type B32 in all respects with the exception of the following:
 - a. Overall width will be 11"
 - b. Overall height will be 11 5/8"
2. For all additional details refer to DWG. 1.63X of the 2008 CAMPUS SIGN PROGRAM

ELEVATION | HALF SIZE

AMENDMENT TO CAMPUS SIGN PROGRAM
 DRAWING 1.63A FOR SIGN TYPE B32A

AUTHORIZED BY:

Timothy Ralston
 JULY 12, 2011

TIMOTHY RALSTON
 ASSOCIATE VICE CHANCELLOR
 CAPITAL RESOURCE MANAGEMENT
 UNIVERSITY OF CALIFORNIA, RIVERSIDE

GENERAL NOTES:

1. Copy shown as typical layouts only, actual layouts to be determined and or verified prior to fabrication.
2. Sign installer to verify existing mounting conditions and use appropriate attachment method as per condition.
3. Braille shall be Calif Grade 2 (Contracted Braille).
4. An inverted "L" shall precede all numbers in Braille.

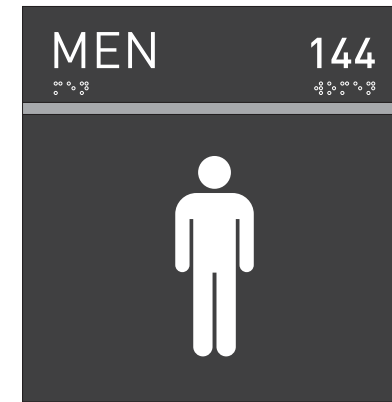

Mens Room

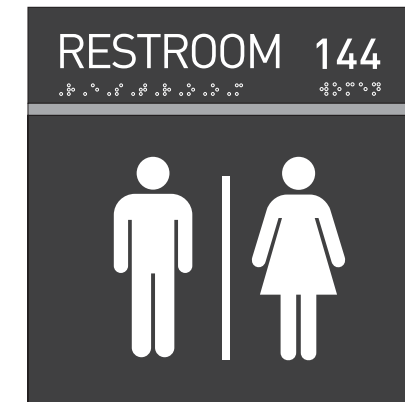

Unisex Restroom

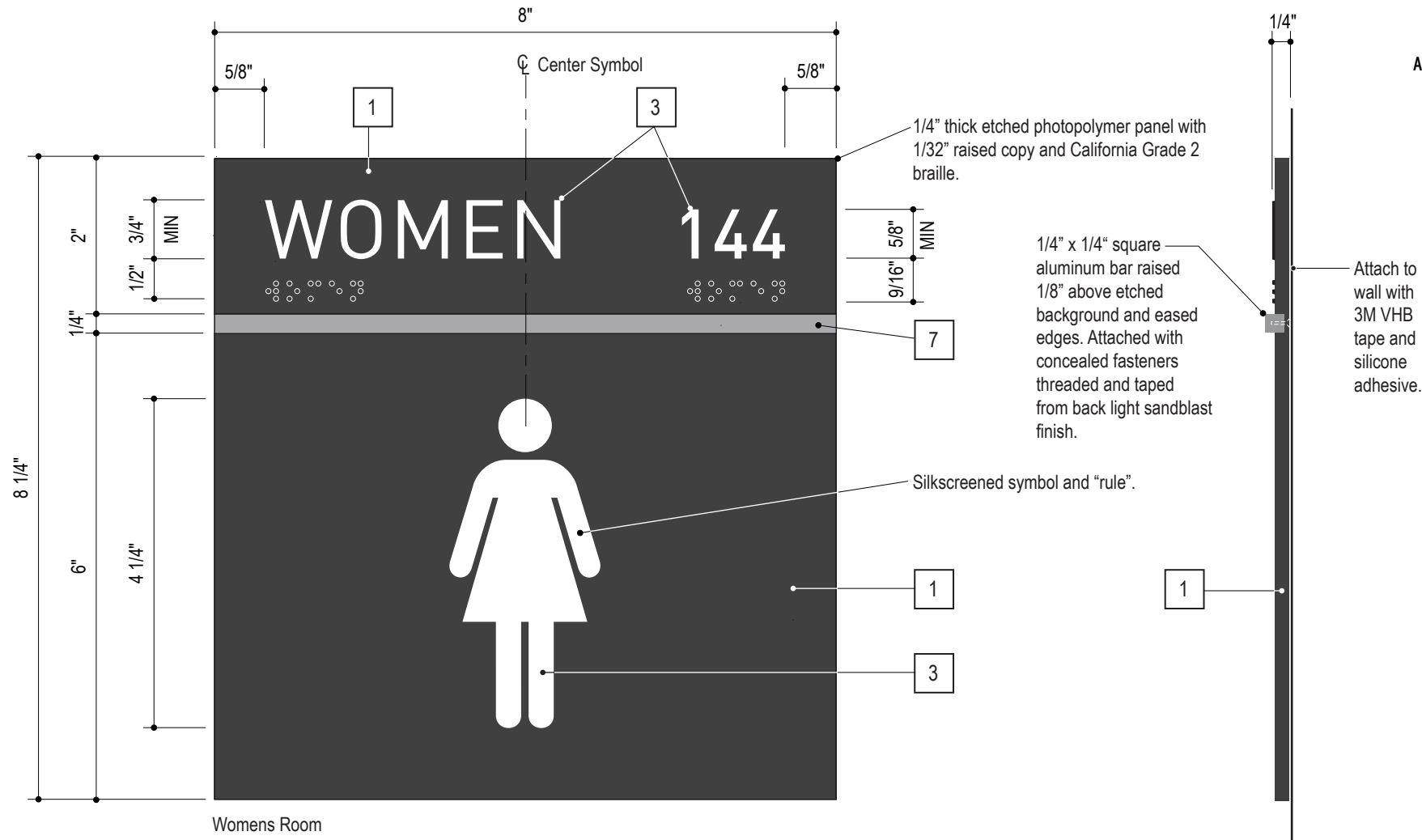

ADDITIONAL LAYOUTS

3"=1'-0"

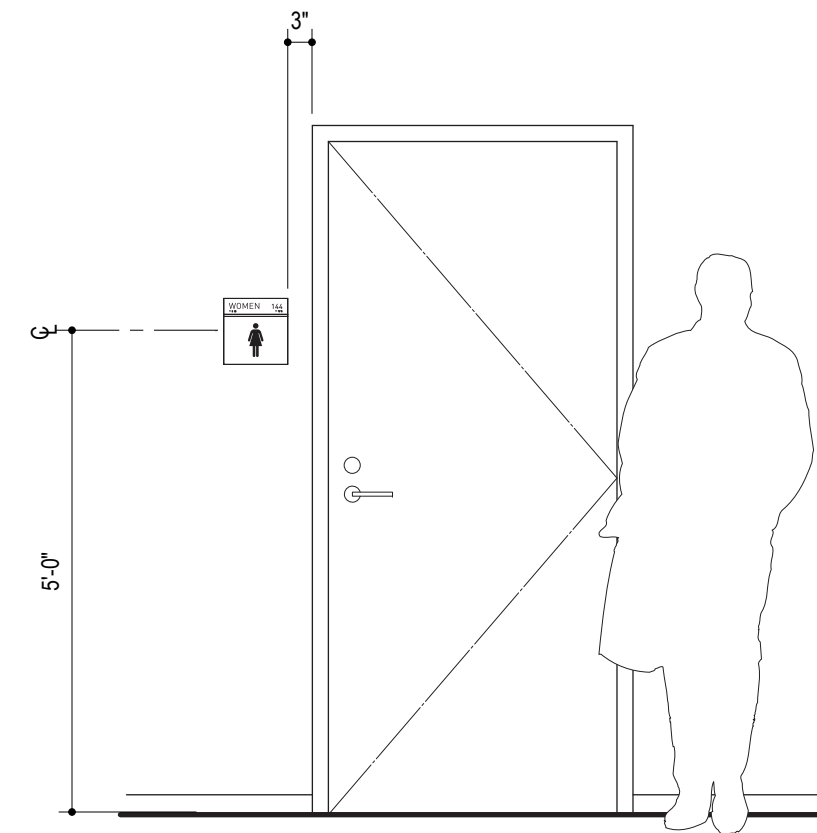

GENERAL NOTES:

1. Copy shown as typical layouts only, actual layouts to be determined and or verified prior to fabrication.
2. Sign installer to verify existing mounting conditions and use appropriate attachment method as per condition.

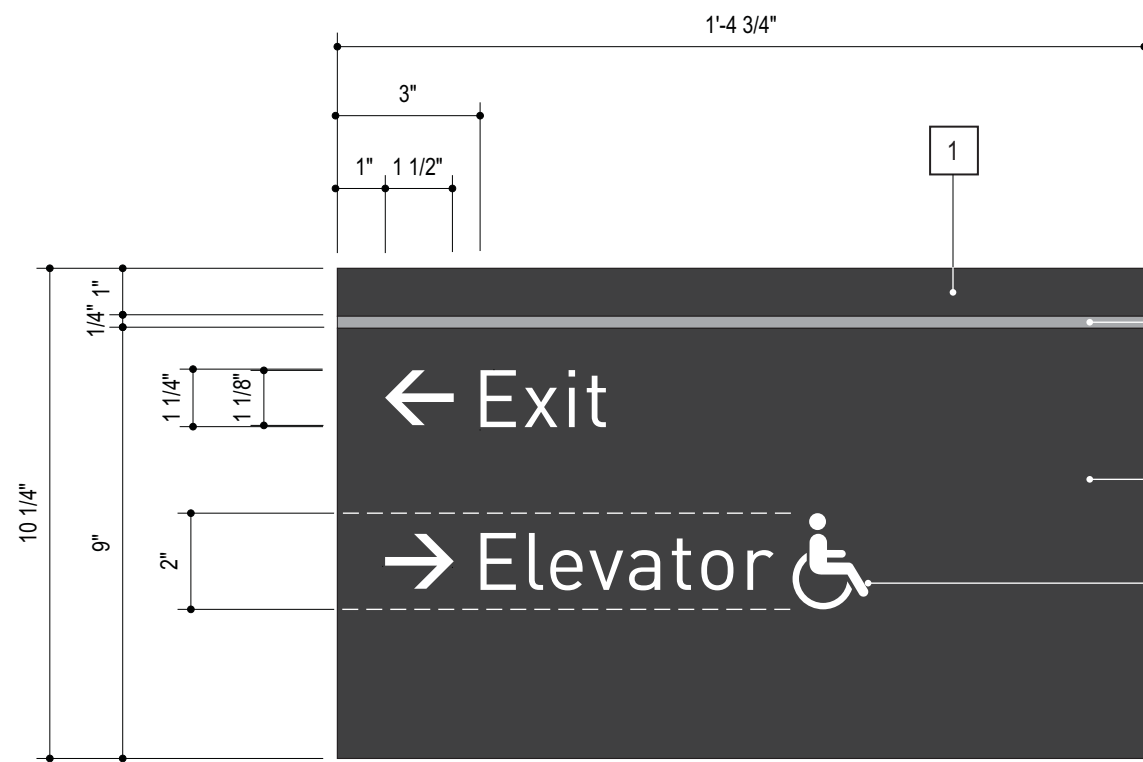

ELEVATION | 3"=1'-0"

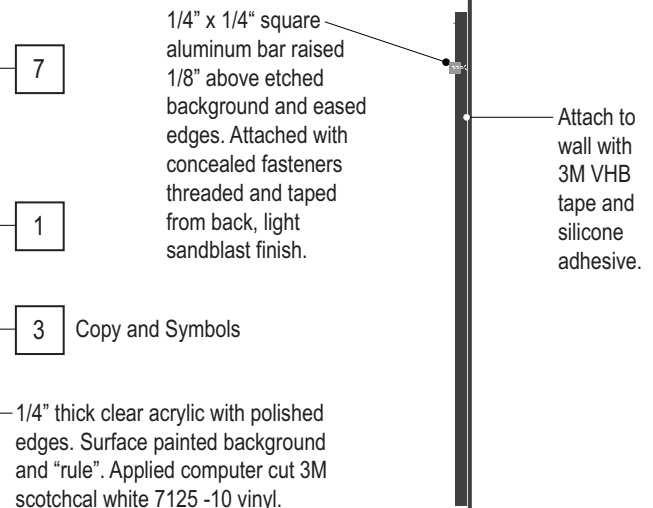

SIDE VIEW | 3"=1'-0"

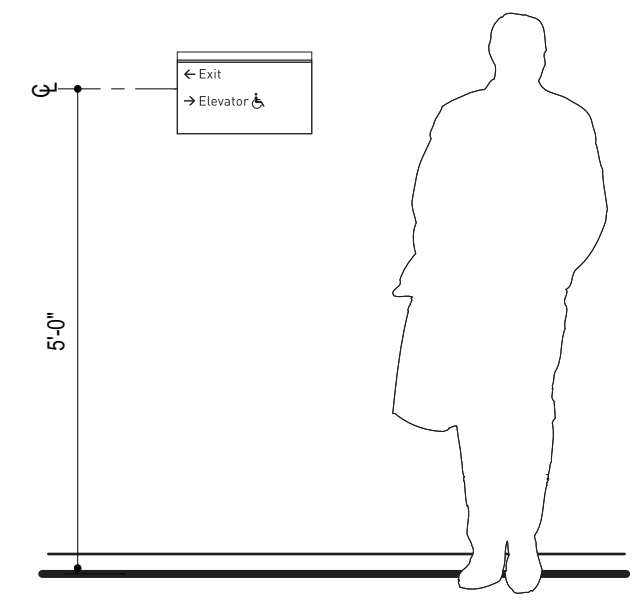

LOCATION ELEVATION | 1/2"=1'-0"

1/4" x 1/4" square aluminum bar raised 1/8" above etched background and eased edges. Attached with concealed fasteners threaded and taped from back, light sandblast finish.

1/4" thick clear acrylic with polished edges. Surface painted background and "rule". Applied computer cut 3M scotchcal white 7125 -10 vinyl.

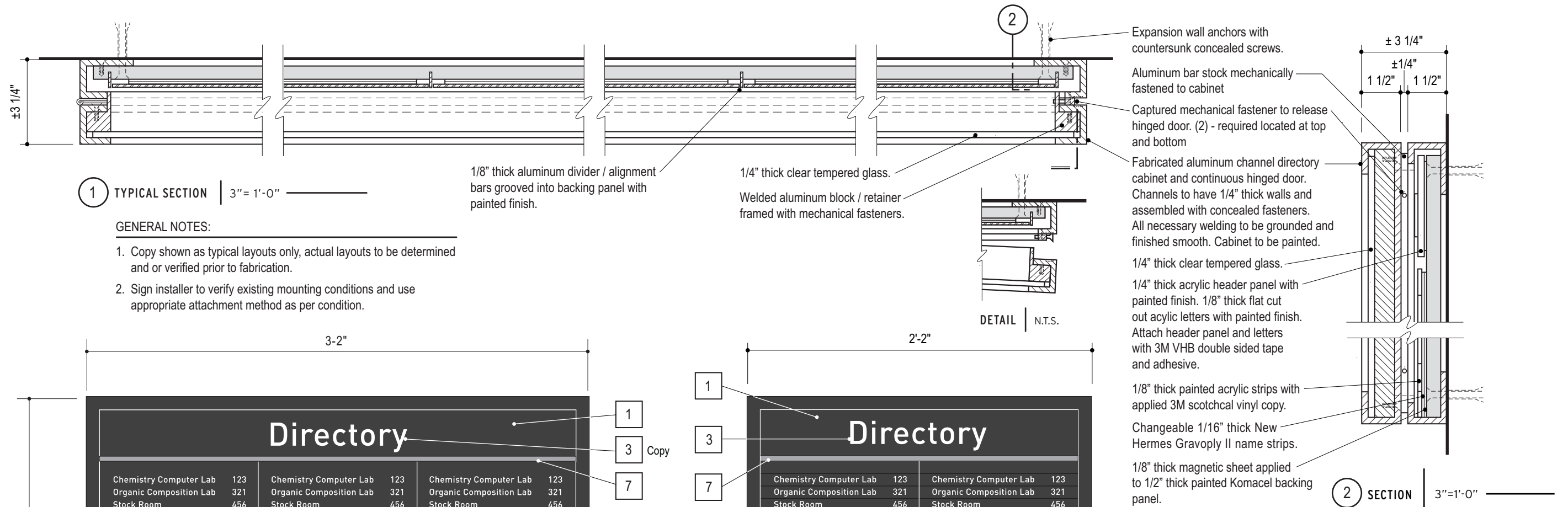

(3) COLUMN ELEVATION | 1 1/2"=1'-0"

3'-2" (Total Height)
 3'-2" (Total Width)

Directory					
Chemistry Computer Lab	123	Chemistry Computer Lab	123	Chemistry Computer Lab	123
Organic Composition Lab	321	Organic Composition Lab	321	Organic Composition Lab	321
Stock Room	456	Stock Room	456	Stock Room	456
Graduate Students Office	654	Graduate Students Office	654	Graduate Students Office	654
Instrumentation Room	415	Instrumentation Room	415	Instrumentation Room	415
Chemistry Computer Lab	123	Chemistry Computer Lab	123	Chemistry Computer Lab	123
Organic Composition Lab	321	Organic Composition Lab	321	Organic Composition Lab	321
Stock Room	456	Stock Room	456	Stock Room	456
Graduate Students Office	654	Graduate Students Office	654	Graduate Students Office	654
Instrumentation Room	415	Instrumentation Room	415	Instrumentation Room	415
Chemistry Computer Lab	123	Chemistry Computer Lab	123	Chemistry Computer Lab	123
Organic Composition Lab	321	Organic Composition Lab	321	Organic Composition Lab	321
Stock Room	456	Stock Room	456	Stock Room	456
Graduate Students Office	654	Graduate Students Office	654	Graduate Students Office	654
Instrumentation Room	415	Instrumentation Room	415	Instrumentation Room	415
Chemistry Computer Lab	123	Chemistry Computer Lab	123	Chemistry Computer Lab	123
Organic Composition Lab	321	Organic Composition Lab	321	Organic Composition Lab	321
Stock Room	456	Stock Room	456	Stock Room	456
Graduate Students Office	654	Graduate Students Office	654	Graduate Students Office	654
Instrumentation Room	415	Instrumentation Room	415	Instrumentation Room	415

Fabricated aluminum cabinet with clear tempered glass face. Hinged door to be locked mechanically with concealed captured screws/pins top and bottom on side of cabinet. Cabinet to be painted on all visible surfaces.
 Changeable New Hermes Gravoply II name strips.

(2) COLUMN ELEVATION | 1 1/2"=1'-0"

2'-2" (Total Width)

Directory			
Chemistry Computer Lab	123	Chemistry Computer Lab	123
Organic Composition Lab	321	Organic Composition Lab	321
Stock Room	456	Stock Room	456
Graduate Students Office	654	Graduate Students Office	654
Instrumentation Room	415	Instrumentation Room	415
Chemistry Computer Lab	123	Chemistry Computer Lab	123
Organic Composition Lab	321	Organic Composition Lab	321
Stock Room	456	Stock Room	456
Graduate Students Office	654	Graduate Students Office	654
Instrumentation Room	415	Instrumentation Room	415
Chemistry Computer Lab	123	Chemistry Computer Lab	123
Organic Composition Lab	321	Organic Composition Lab	321
Stock Room	456	Stock Room	456
Graduate Students Office	654	Graduate Students Office	654
Instrumentation Room	415	Instrumentation Room	415
Chemistry Computer Lab	123	Chemistry Computer Lab	123
Organic Composition Lab	321	Organic Composition Lab	321
Stock Room	456	Stock Room	456
Graduate Students Office	654	Graduate Students Office	654
Instrumentation Room	415	Instrumentation Room	415

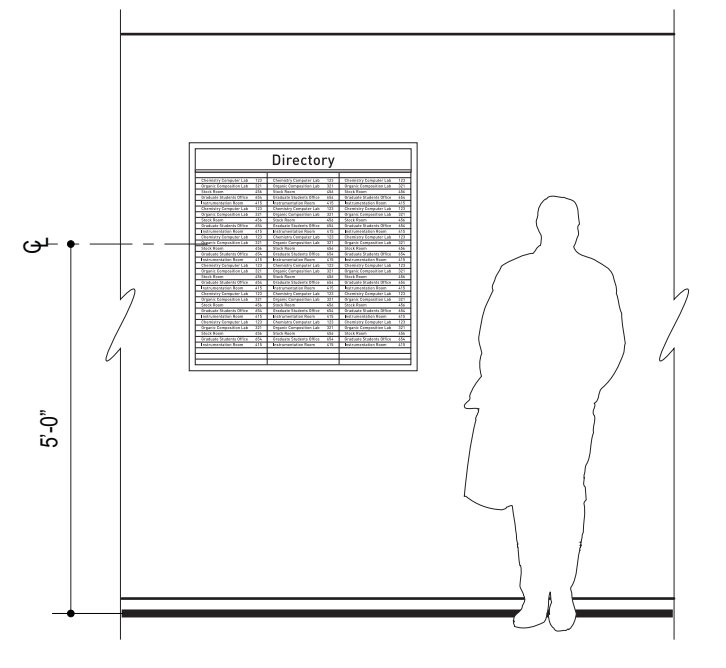

GENERAL NOTES:

1. Copy shown as typical layouts only, actual layouts to be determined and or verified prior to fabrication.
2. Sign installer to verify existing mounting conditions and use appropriate attachment method as per condition.

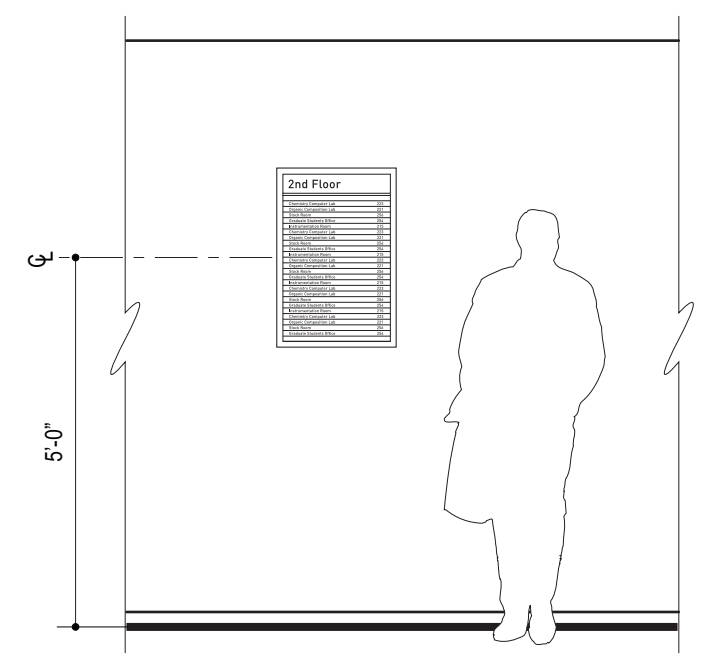
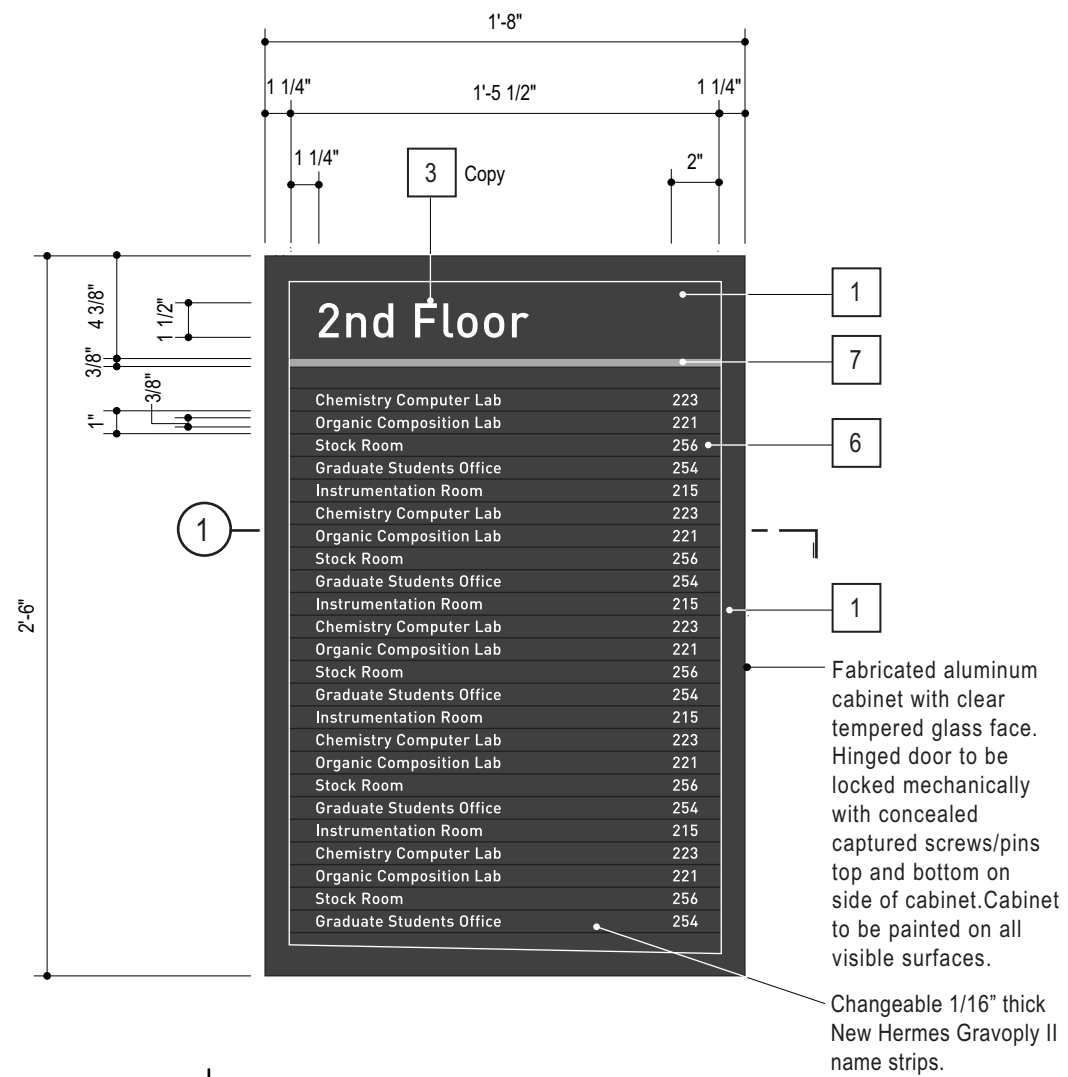
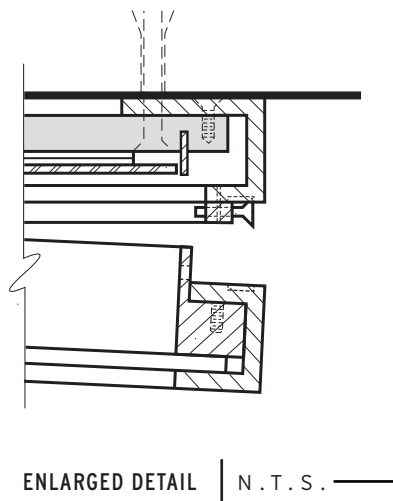
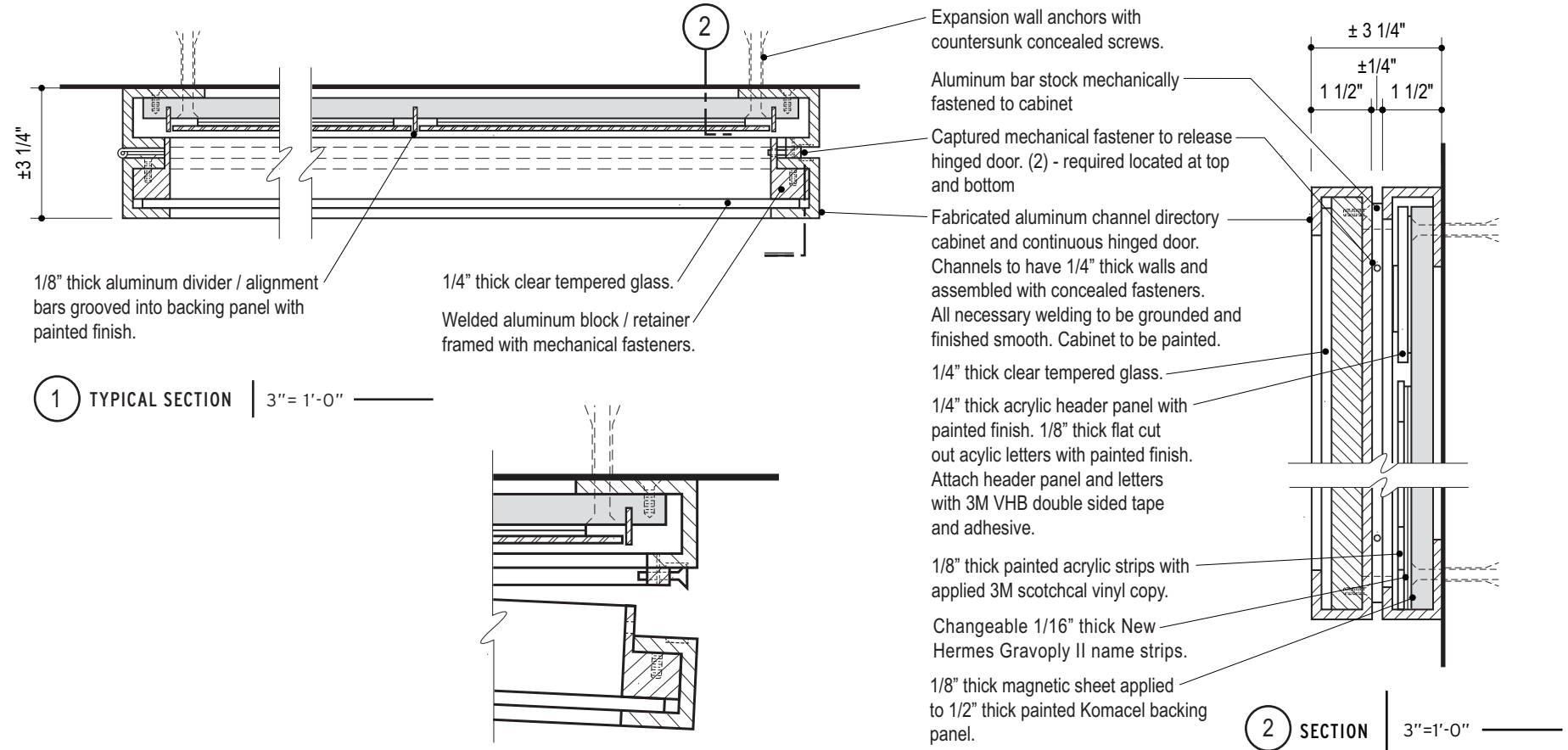

GENERAL NOTES:

1. Copy shown as typical layouts only, actual layouts to be determined and or verified prior to fabrication.
2. Sign installer to verify existing mounting conditions and use appropriate attachment method as per condition.

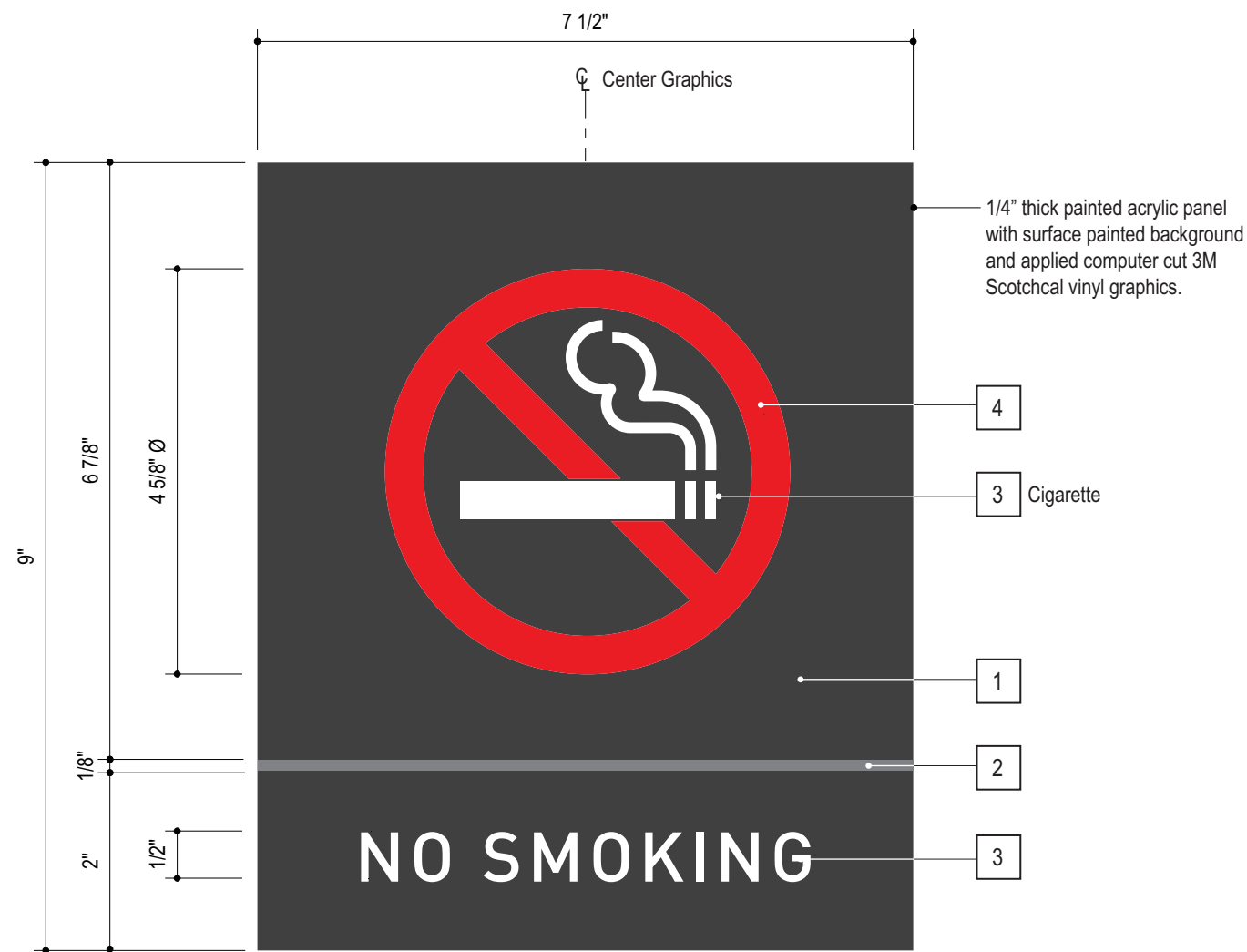
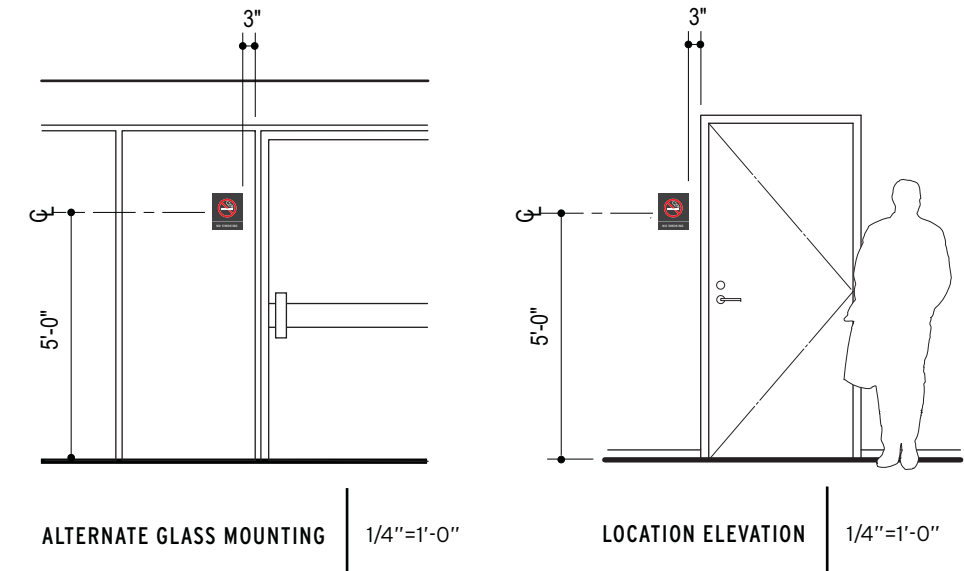

ELEVATION | HALF SIZE

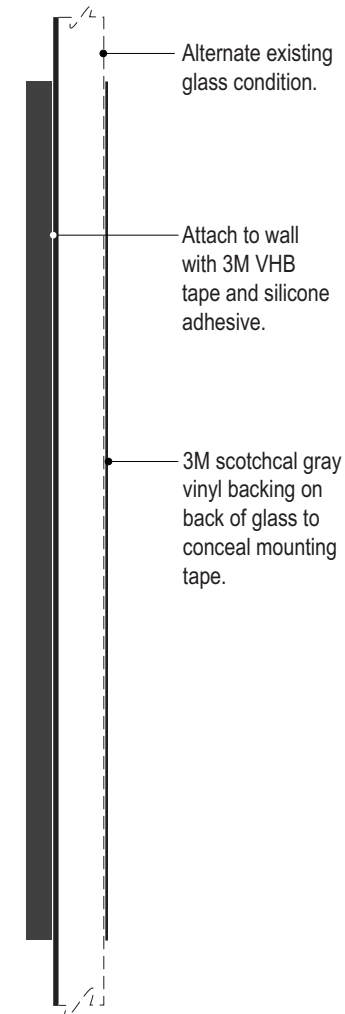

SIDE VIEW | HALF SIZE

NO FOOD OR DRINK

NO FOOD OR DRINK in building

ACADEMIC STUDY AREA

Sleeping, laying down, shoes/feet on furniture are not permitted

Assistive Listening Device available from (location T.B.D.)

ADDITIONAL LAYOUTS | HALF SIZE

GENERAL NOTES:

1. Copy shown as typical layouts only, actual layouts to be determined and or verified prior to fabrication.
2. Sign installer to verify existing mounting conditions and use appropriate attachment method as per condition.

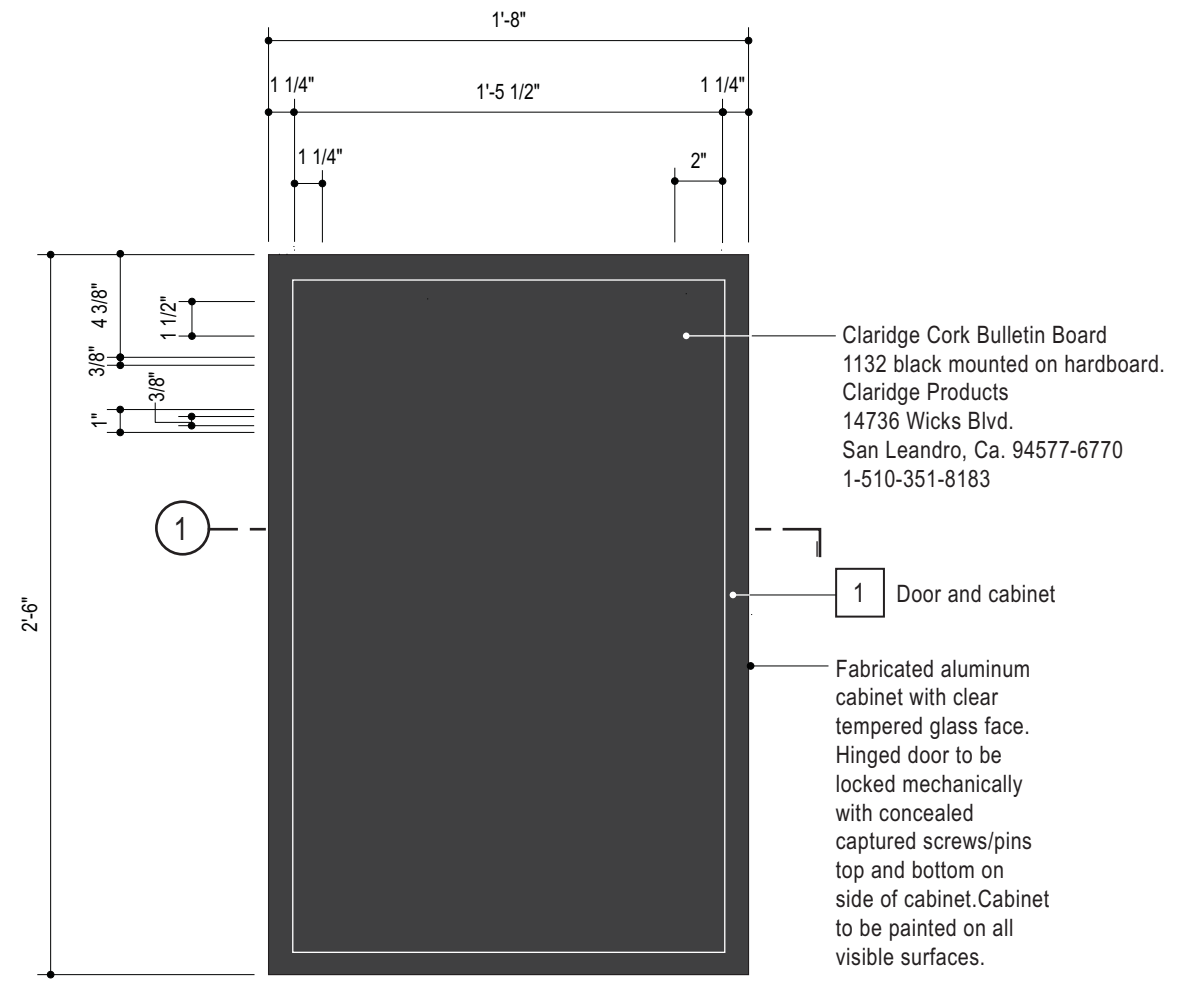
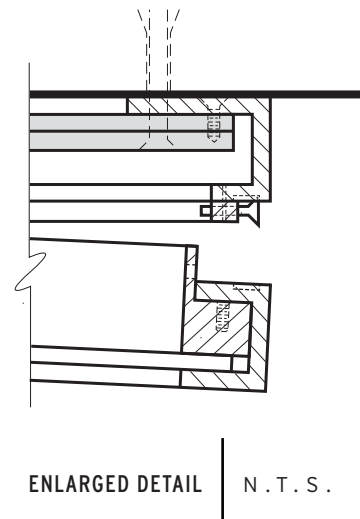
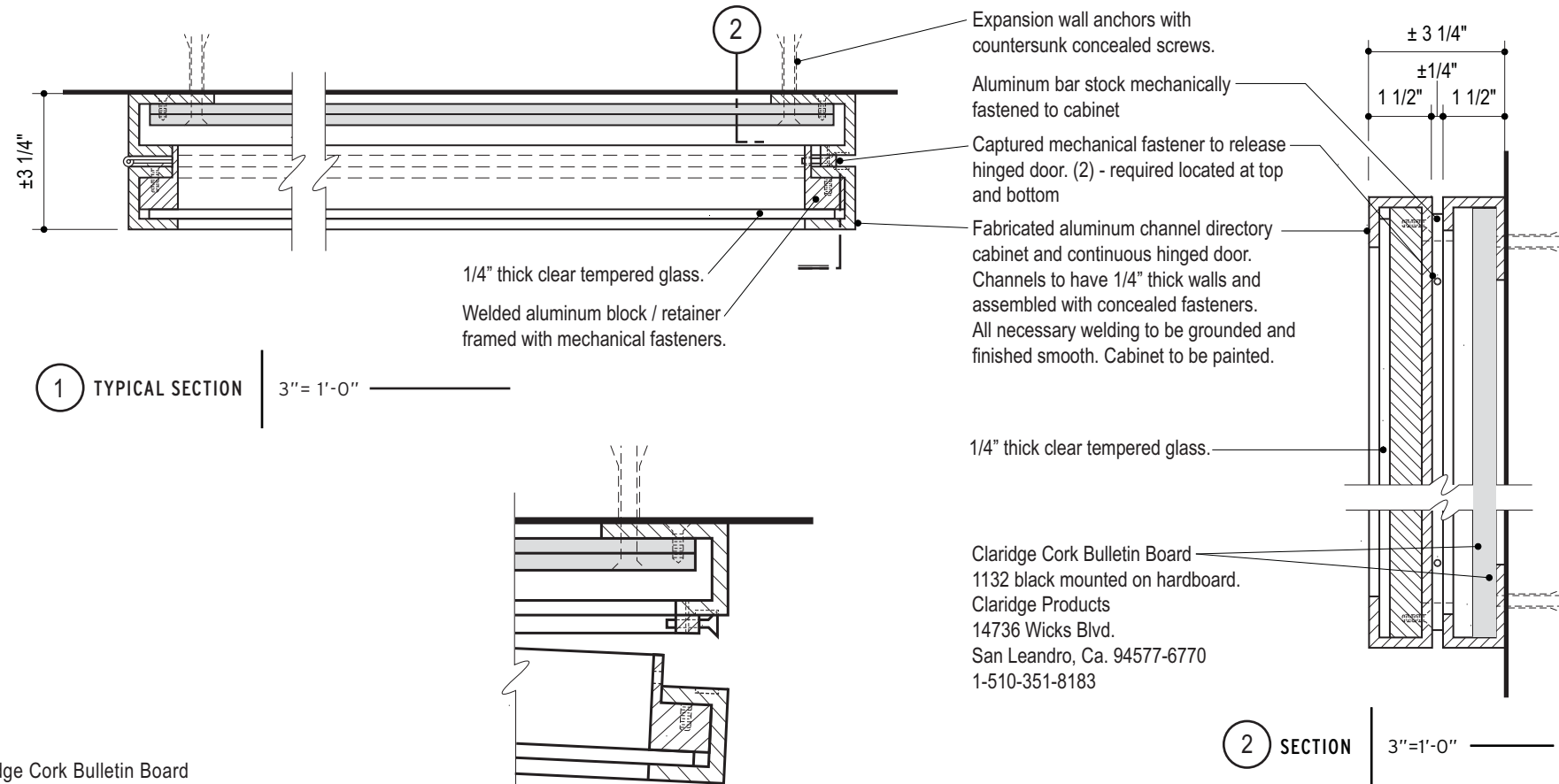

ELEVATION | 1 1/2"=1'-0"

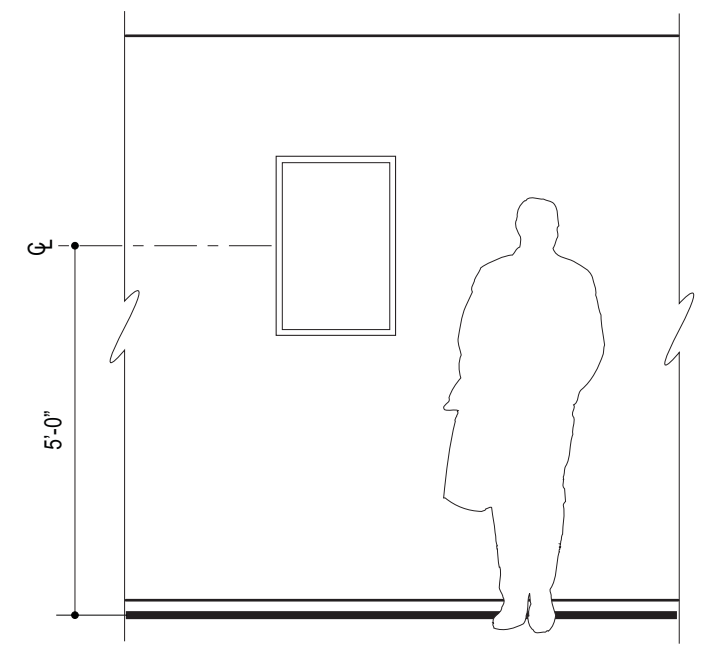

LOCATION ELEVATION | 3/8"=1'-0"

GENERAL NOTES:

1. Copy shown as typical layouts only, actual layouts to be determined and or verified prior to fabrication.
2. Sign installer to verify existing mounting conditions and use appropriate attachment method as per condition.
3. Braille shall be Calif Grade 2 (Contracted Braille).
4. An inverted "L" shall precede all numbers in Braille.

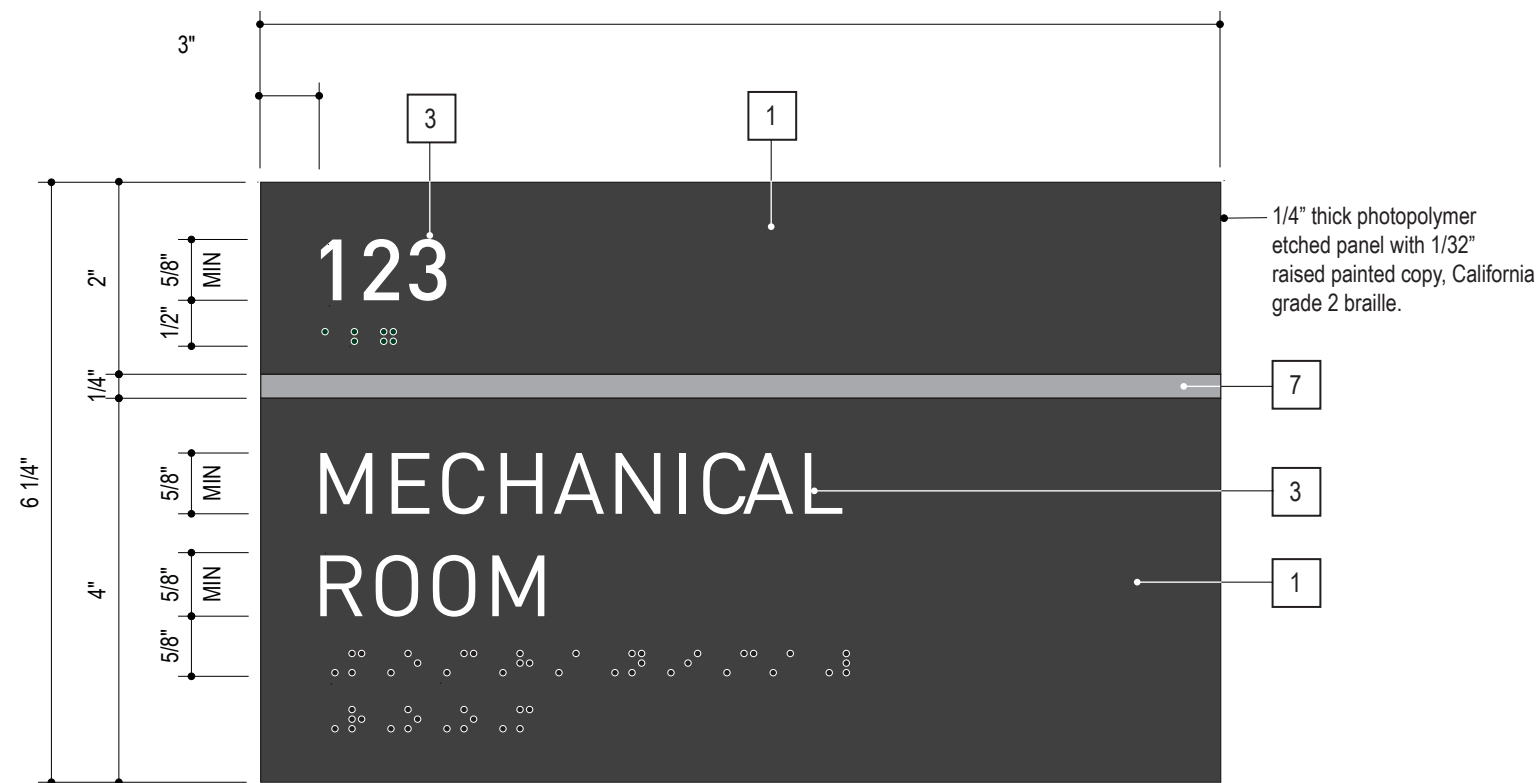

ELEVATION | HALF SIZE

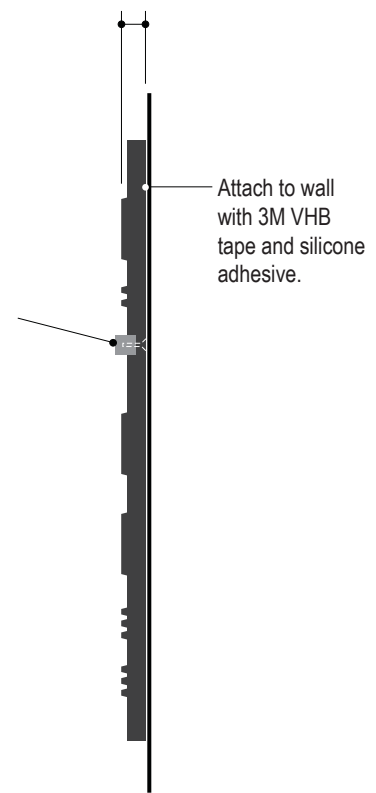

SIDE VIEW | HALF SIZE

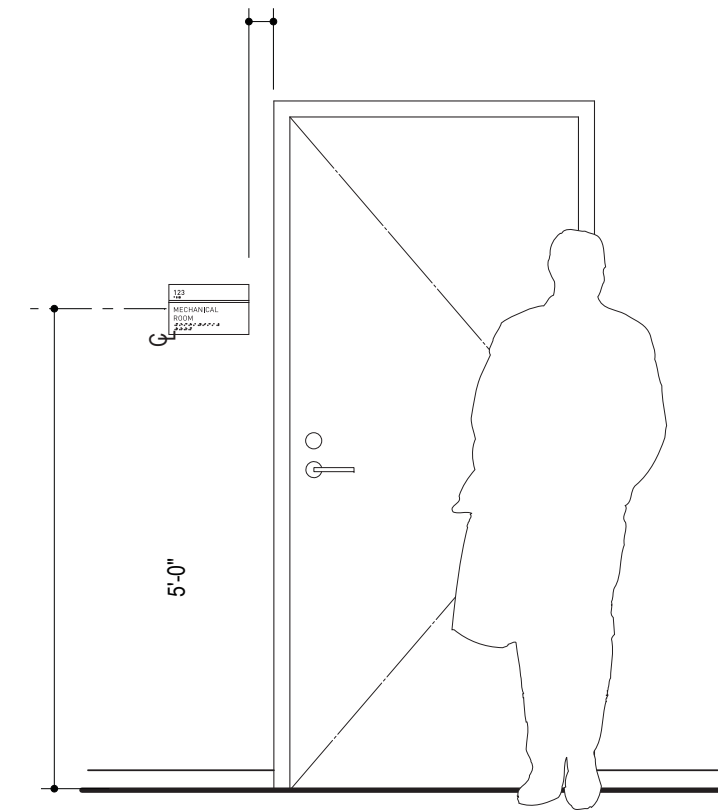

LOCATION ELEVATION | 1/2"=1'-0"

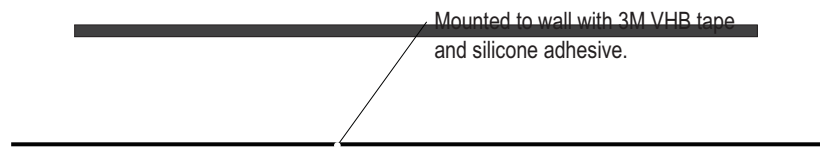

PLAN VIEW | 3"=1'-0"

C

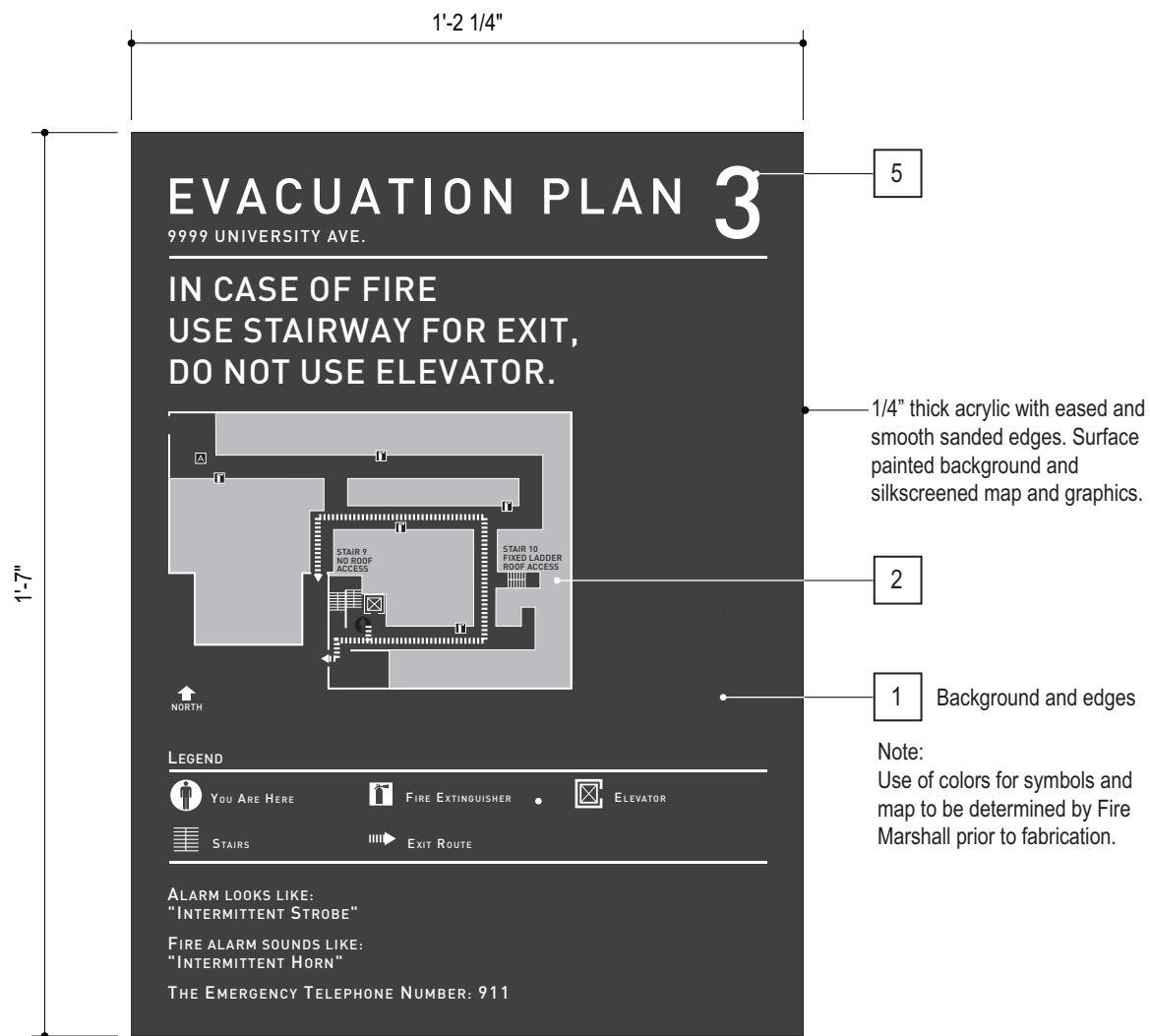

Horizontal Map Layout

ELEVATION | 3"=1'-0"



Vertical Map Layout

ELEVATION | 3"=1'-0"

GENERAL NOTES:

1. Copy shown as typical layouts only, actual layouts to be determined and or verified prior to fabrication.
2. Sign installer to verify existing mounting conditions and use appropriate attachment method as per condition

3. Contact UCR Capital Programs for template artwork in Adobe Illustrator format.

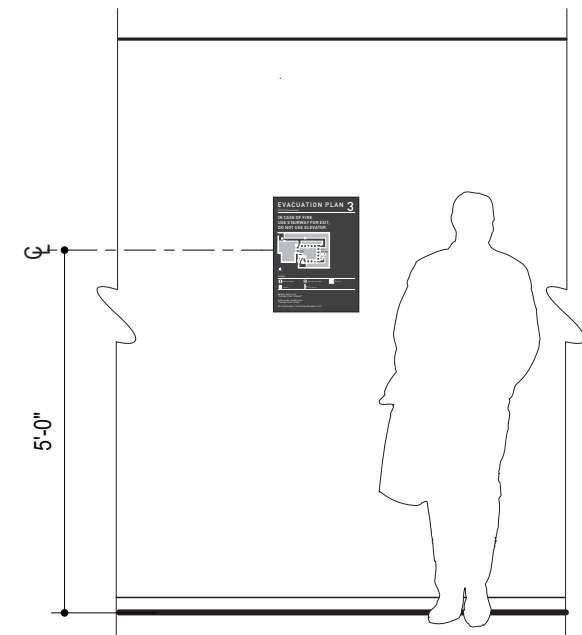

LOCATION ELEVATION | 3/8"=1'-0"

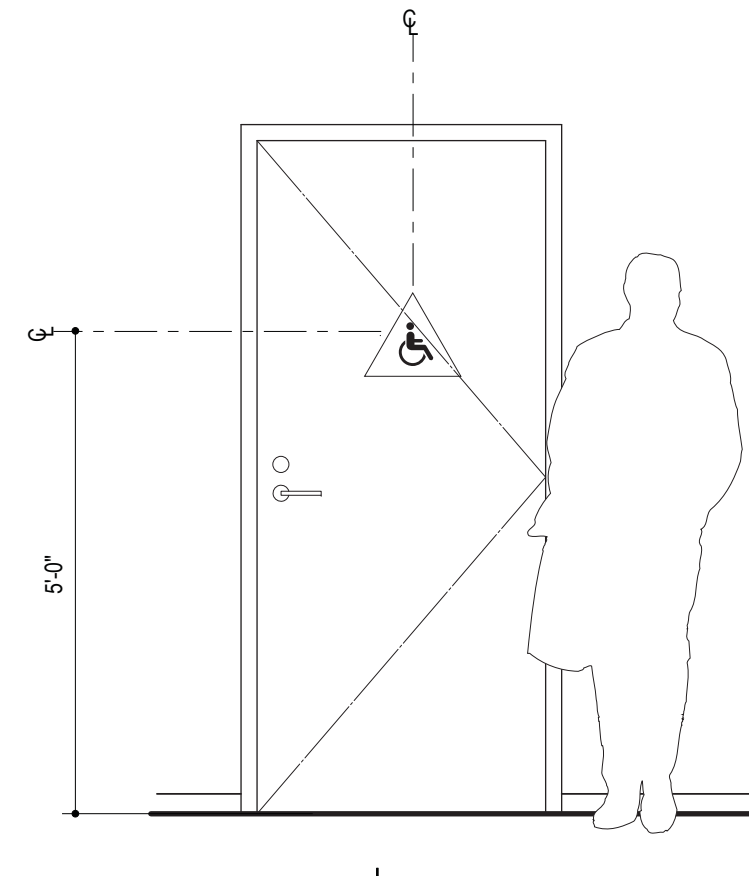
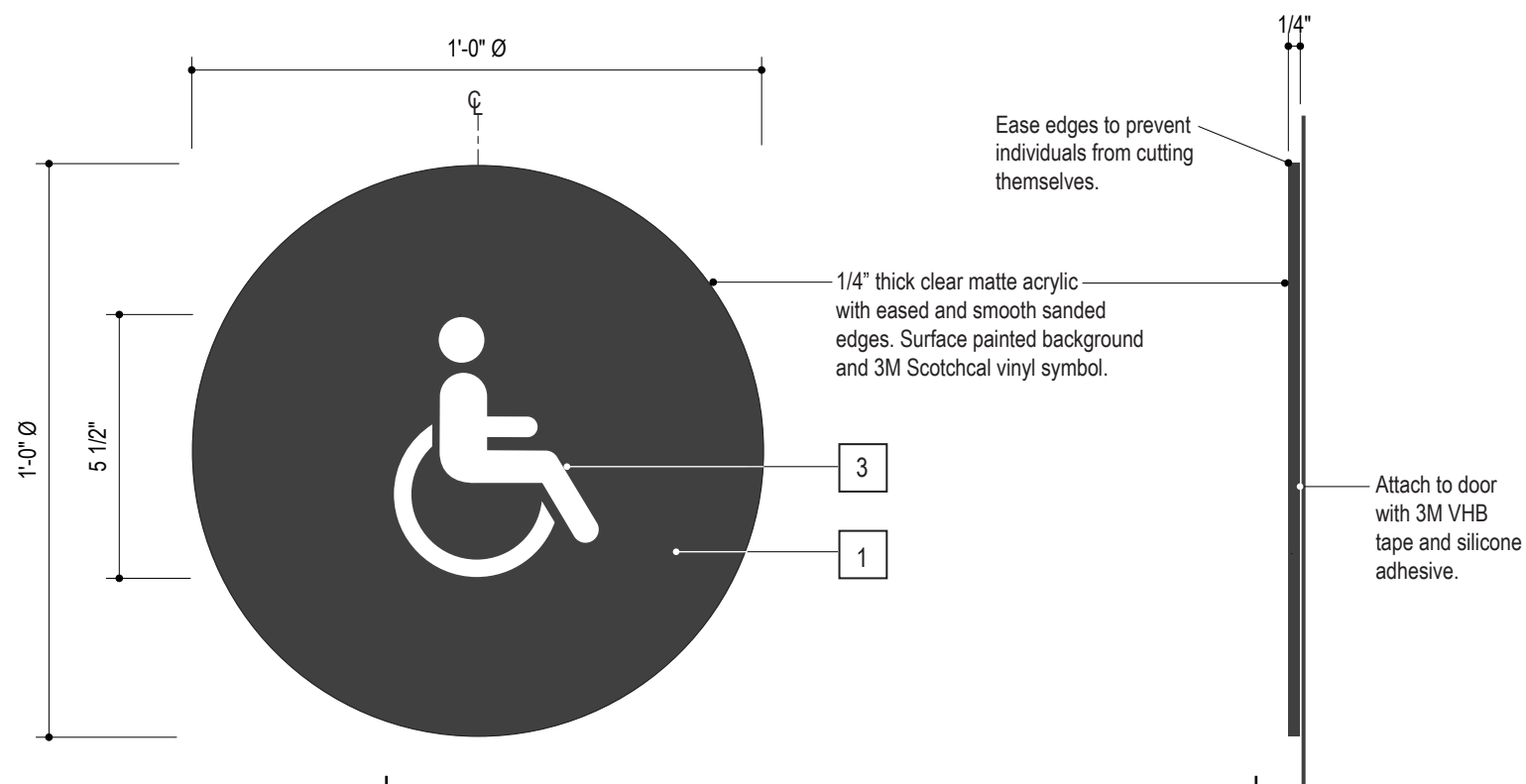
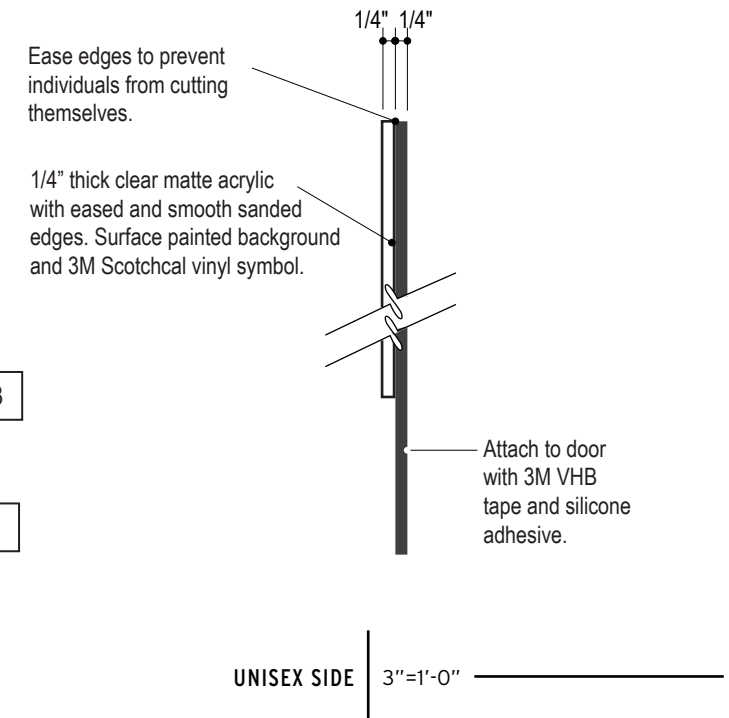
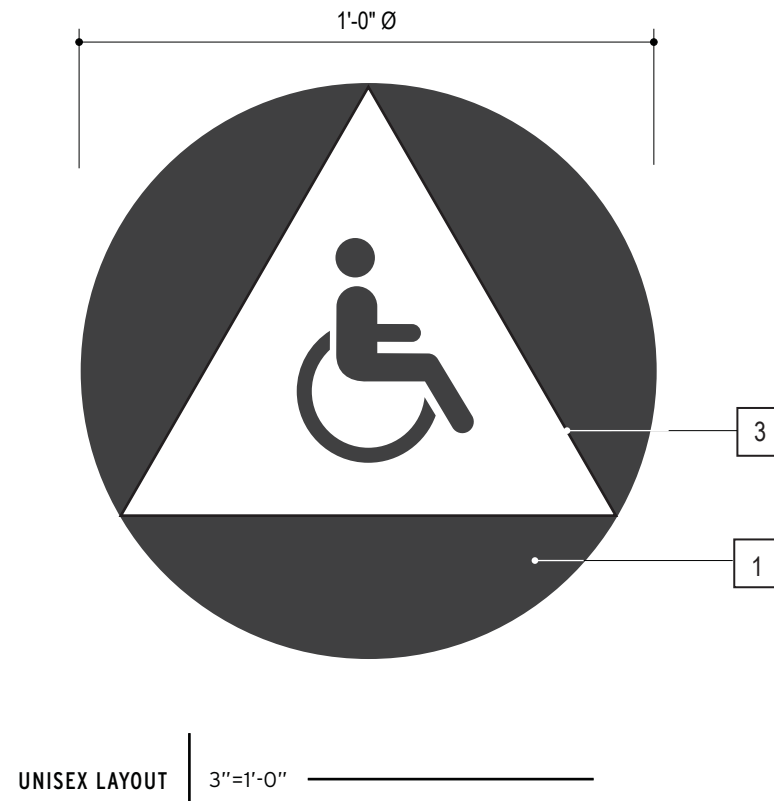
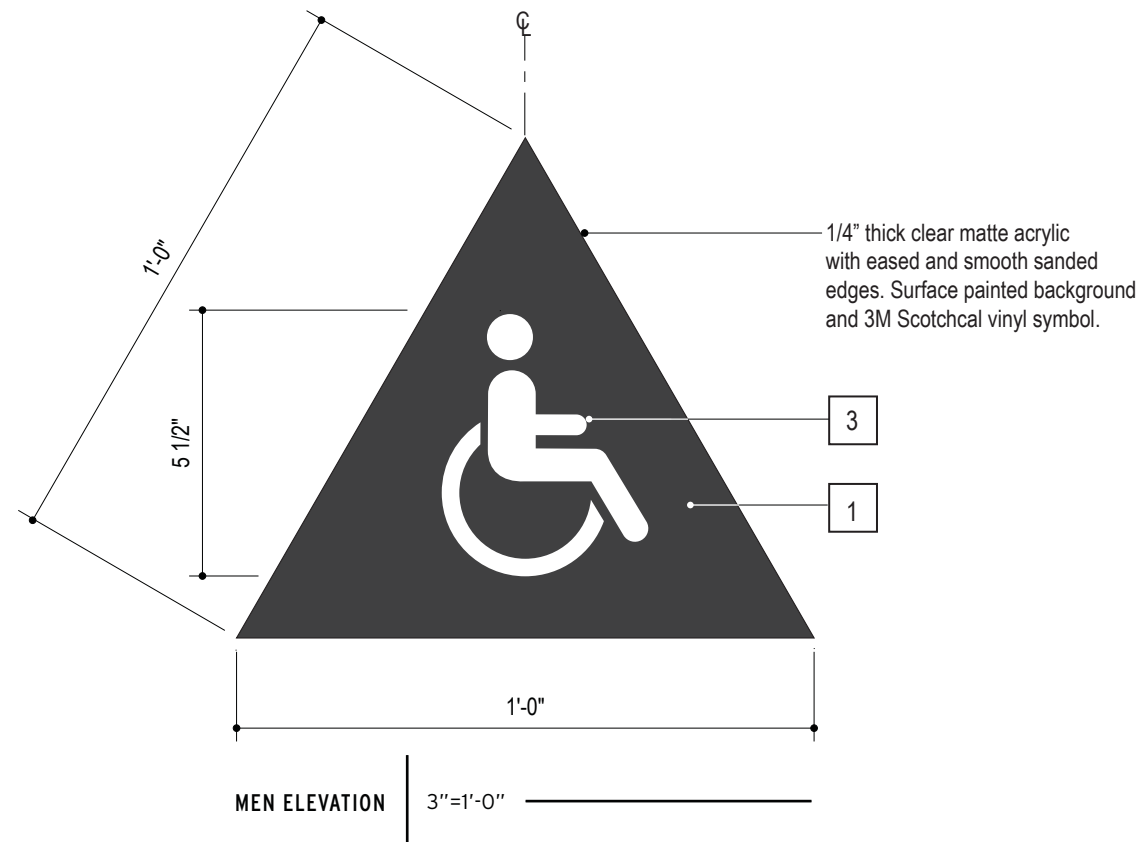

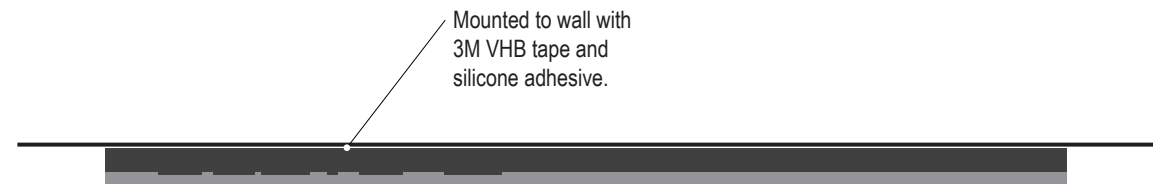

PLAN VIEW

HALF SIZE

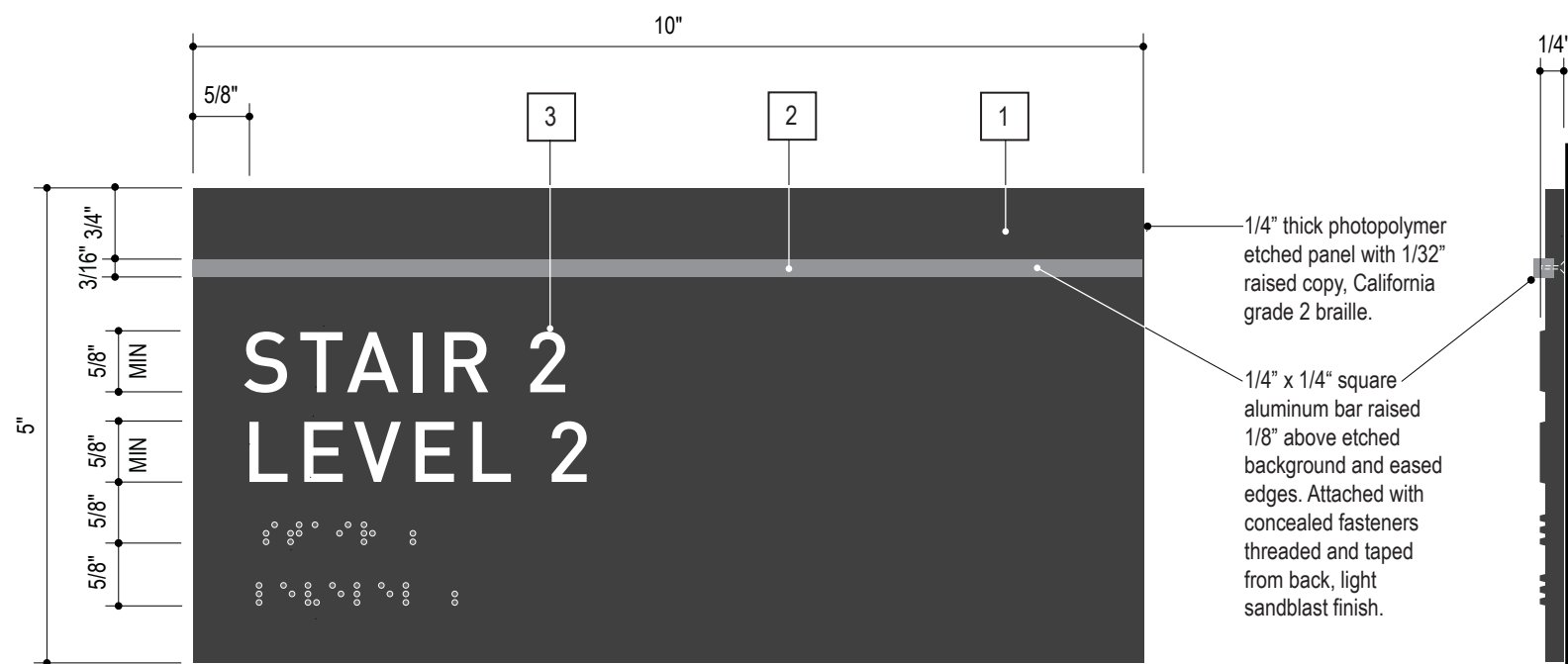

ELEVATION

HALF SIZE

SIDE VIEW

HALF SIZE

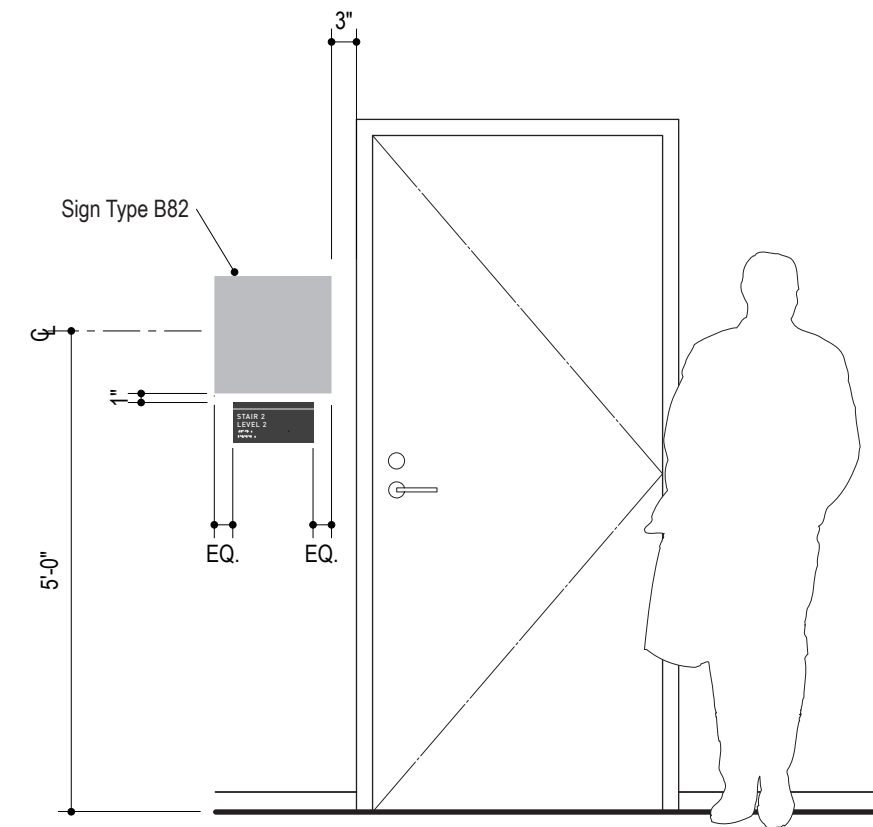

LOCATION ELEVATION

1/2"=1'-0"

GENERAL NOTES:

1. Copy shown as typical layouts only, actual layouts to be determined and or verified prior to fabrication.
2. Sign installer to verify existing mounting conditions and use appropriate attachment method as per condition.
3. Braille shall be Calif Grade 2 (Contracted Braille).
4. An inverted "L" shall precede all numbers in Braille.

GENERAL NOTES:

1. Copy shown as typical layouts only, actual layouts to be determined and or verified prior to fabrication.
2. Sign installer to verify existing mounting conditions and use appropriate attachment method as per condition.

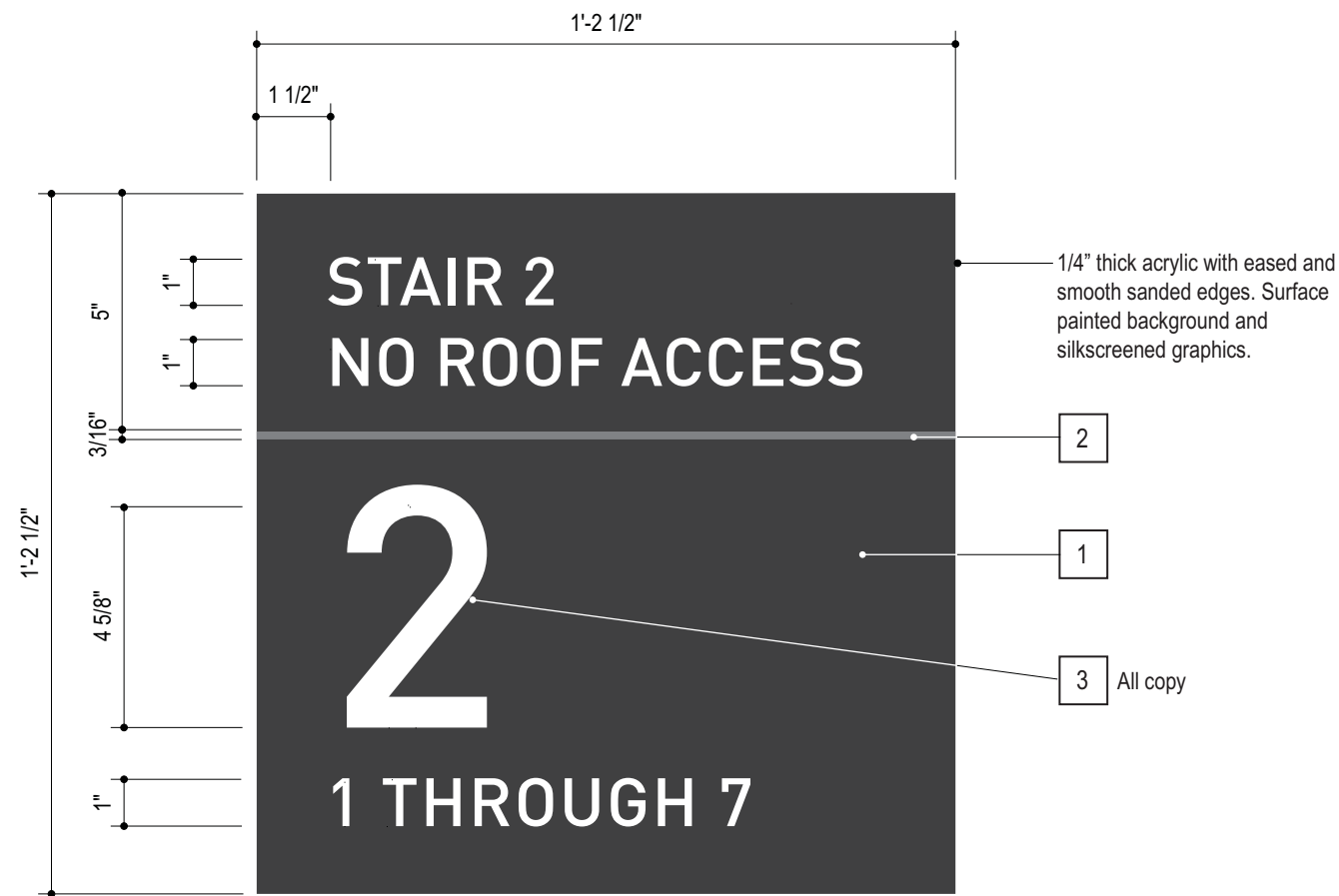

ELEVATION | 3"=1'-0"

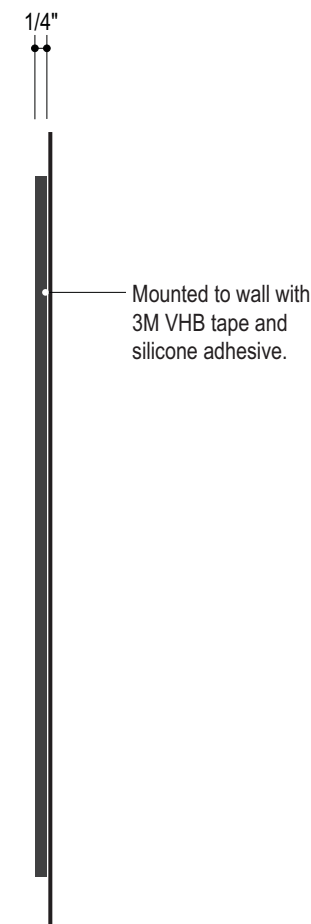

SIDE VIEW | 3"=1'-0"

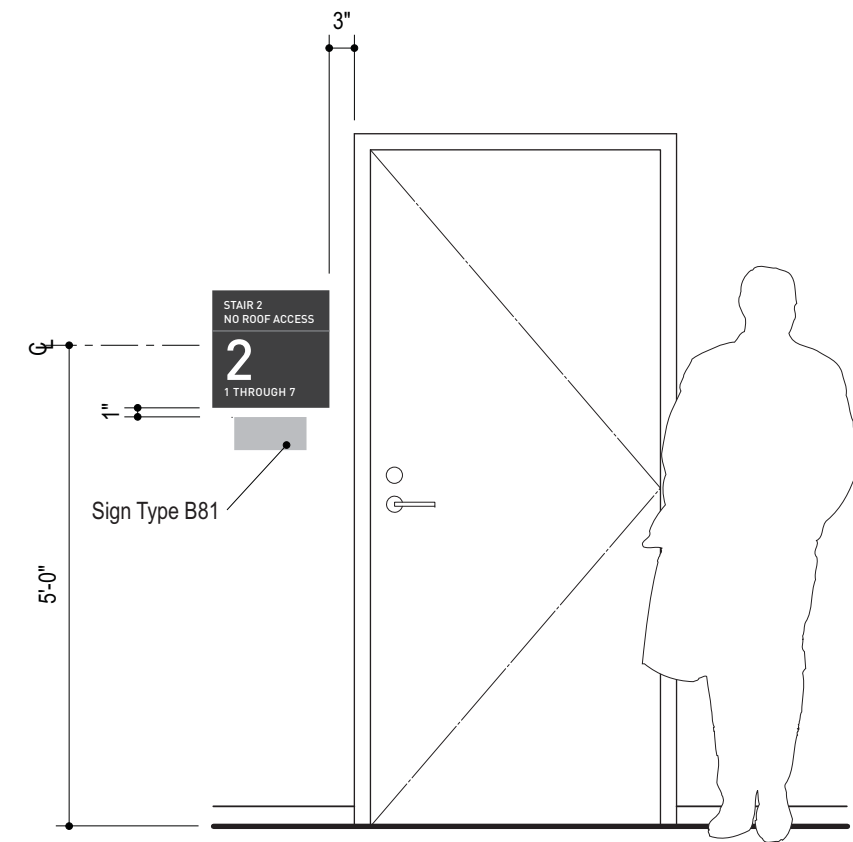

LOCATION ELEVATION | 1/2"=1'-0"

GENERAL NOTES:

1. Copy shown as typical layouts only, actual layouts to be determined and or verified prior to fabrication.
2. Sign installer to verify existing mounting conditions and use appropriate attachment method as per condition.

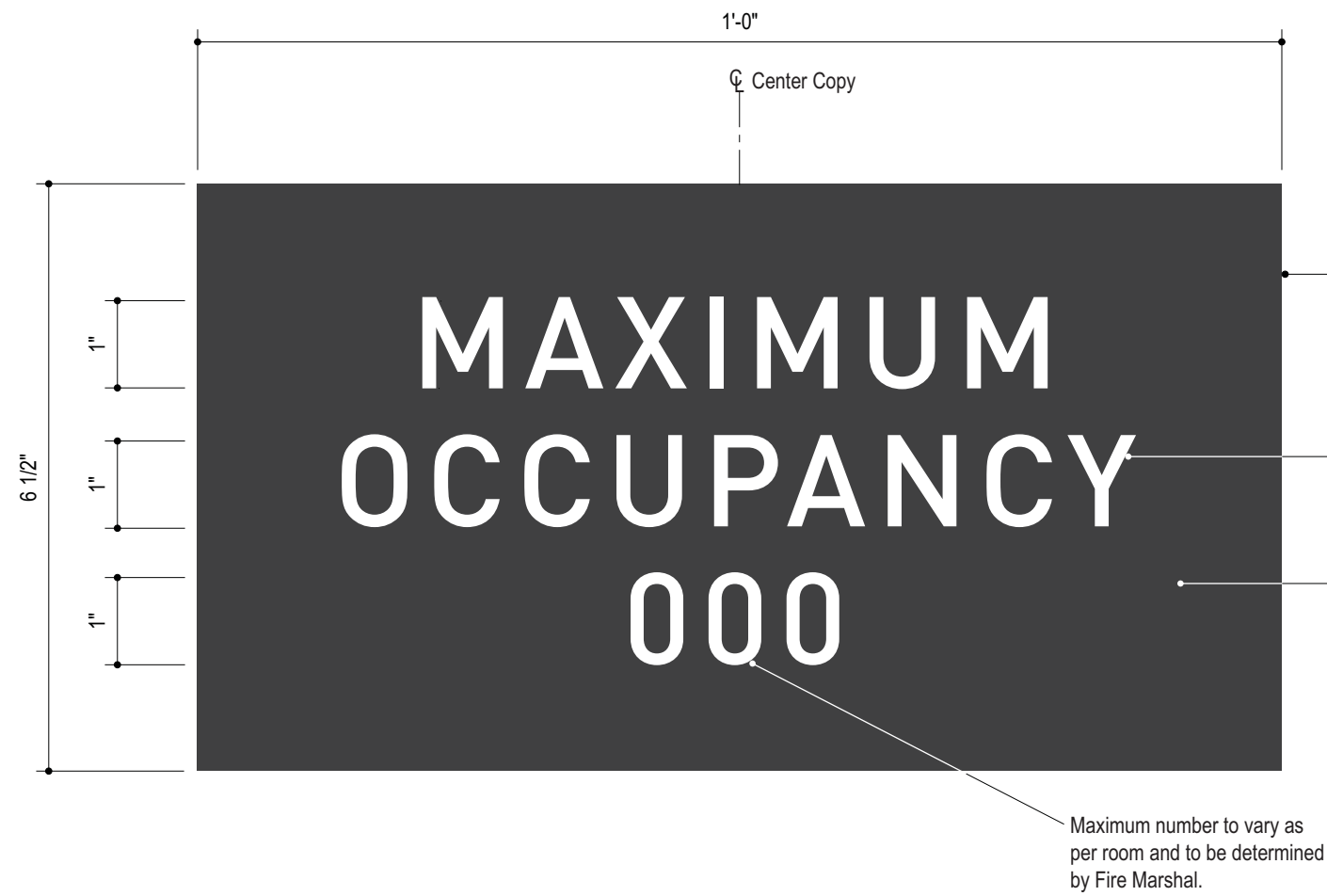

ELEVATION | HALF SIZE

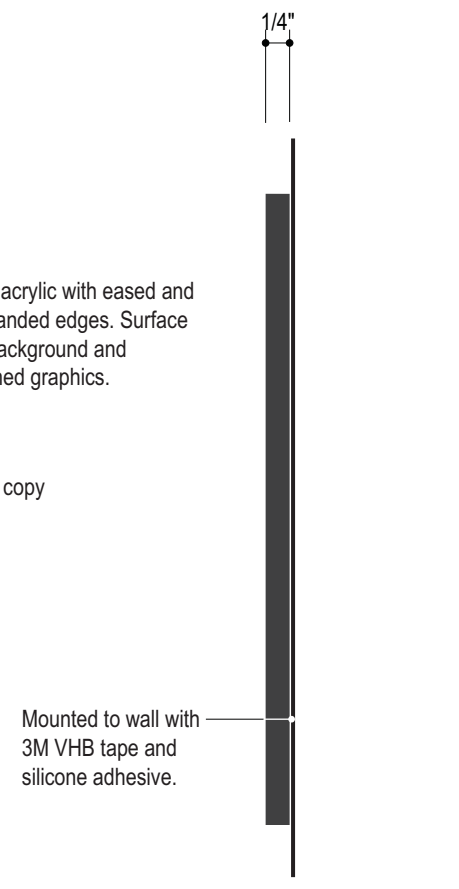

SIDE VIEW | HALF SIZE

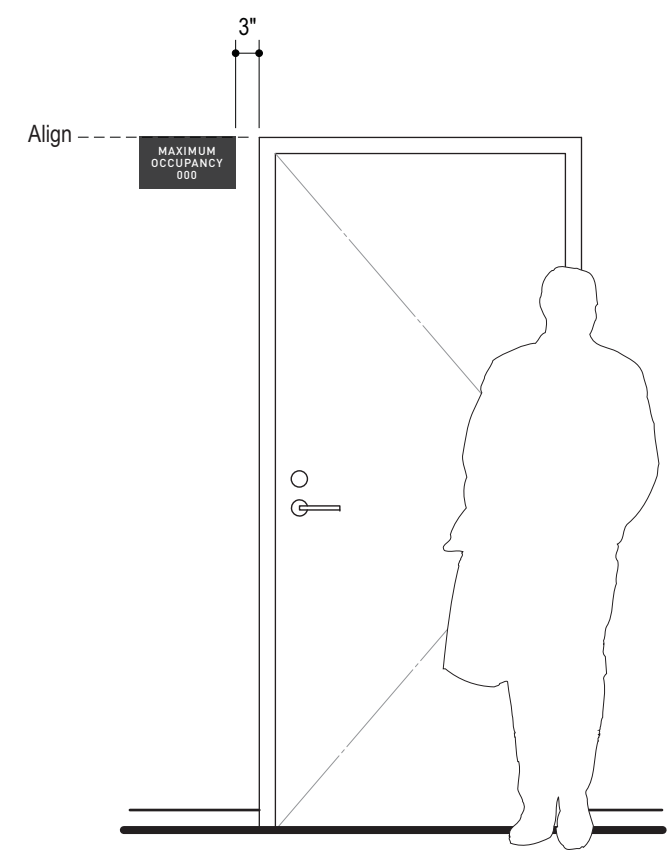

LOCATION ELEVATION | 1/2"=1'-0"



Computer cut 3M Scotchcal vinyl copy with color being gray or white as determined by existing surface color.

ELEVATION

3"=1'-0"

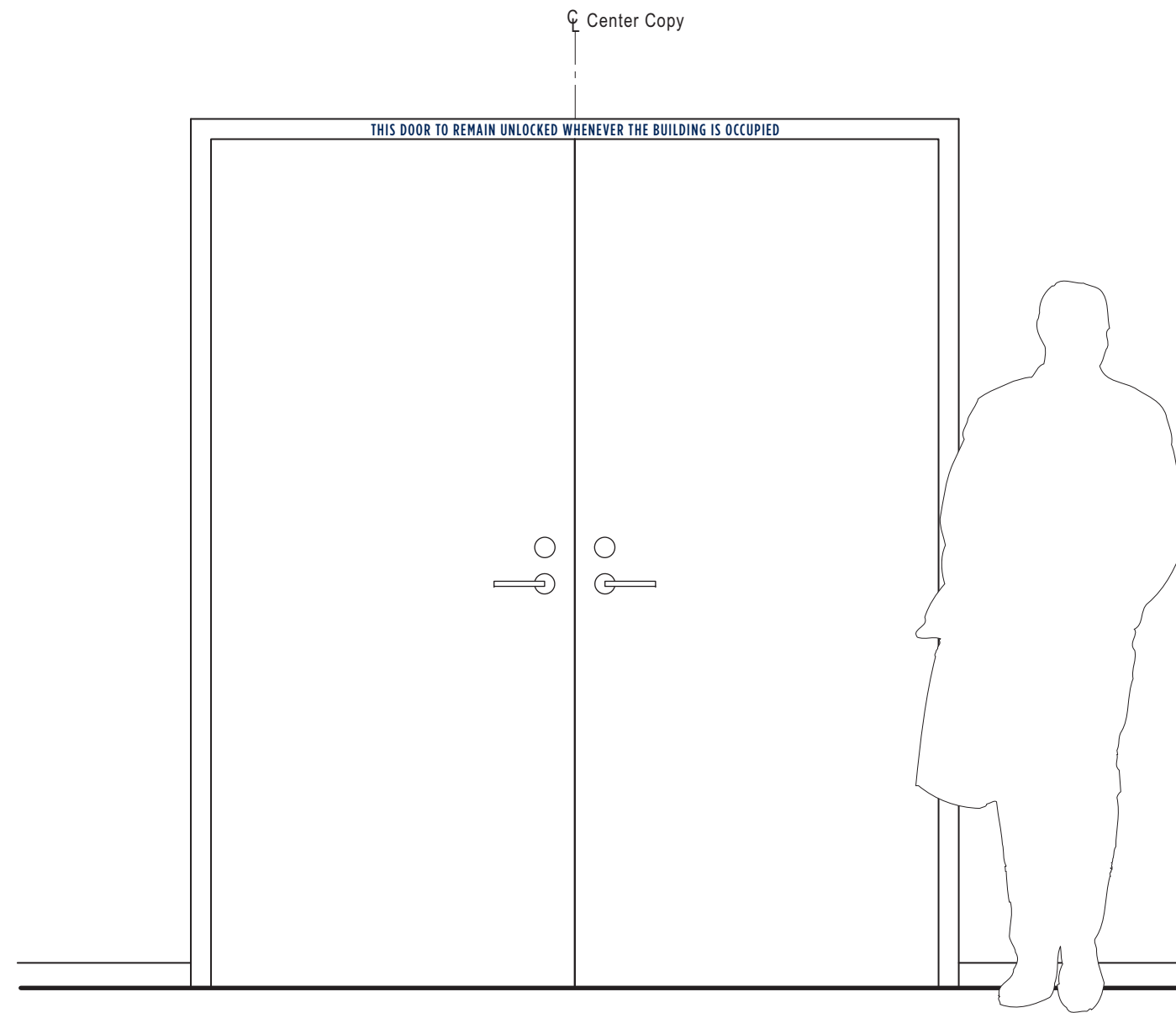

LOCATION ELEVATION

3/4"=1'-0"

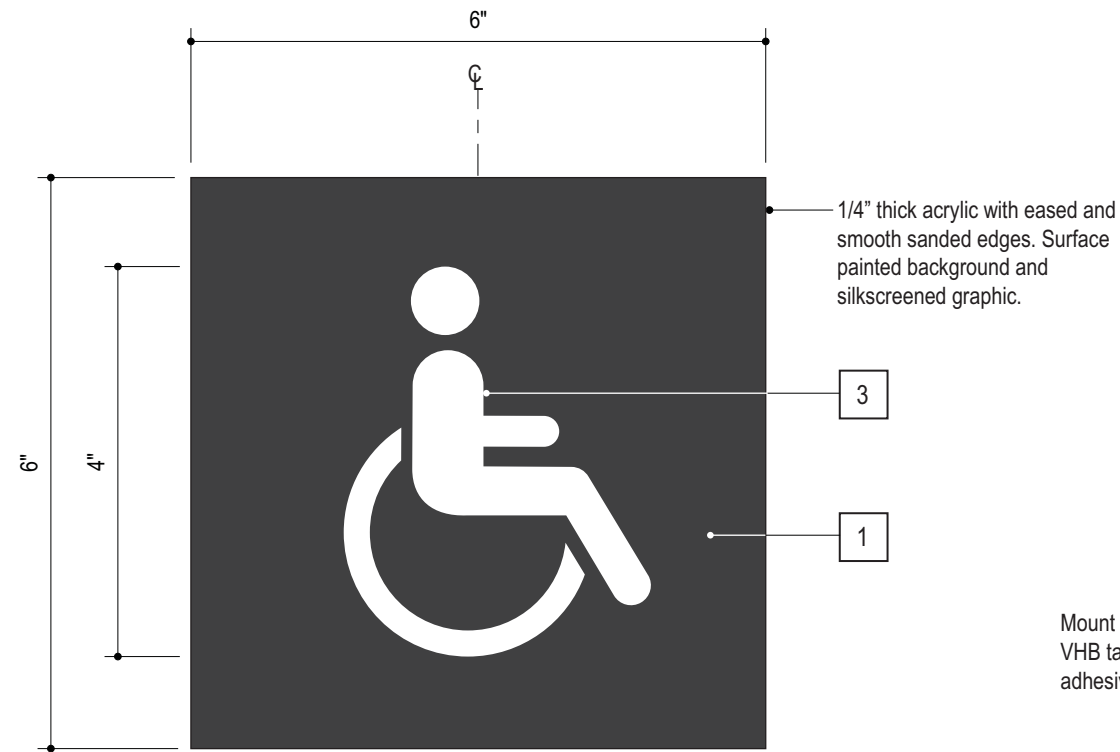

ELEVATION | HALF SIZE

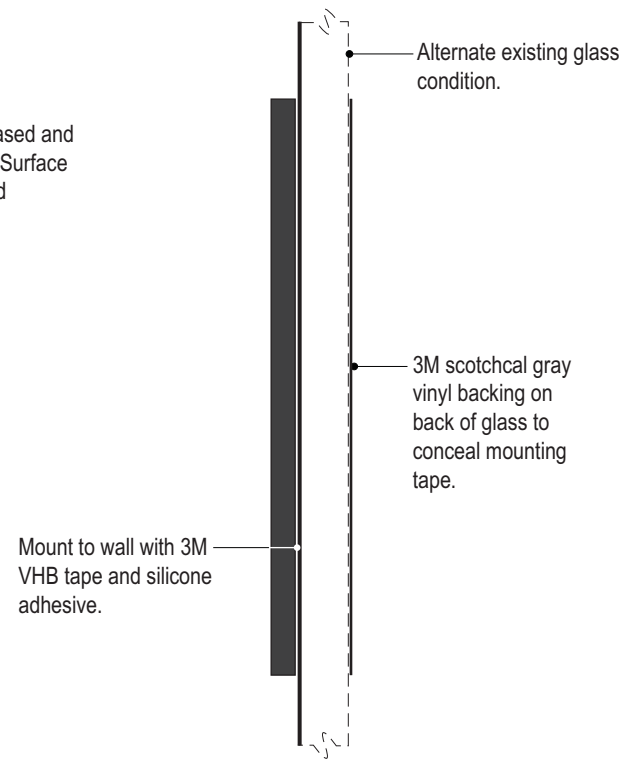

SIDE VIEW | HALF SIZE

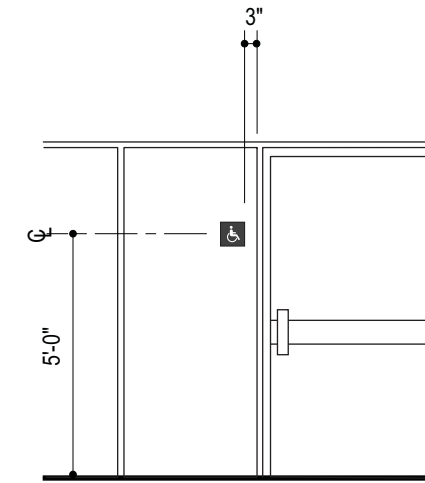

ALTERNATE GLASS MOUNTING | 1/4"=1'-0"

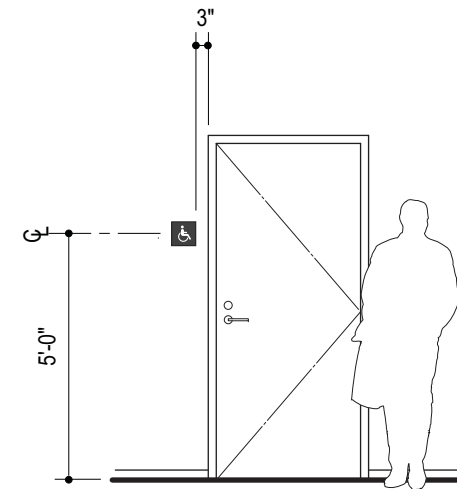

LOCATION ELEVATION | 1/4"=1'-0"

GENERAL NOTES:

1. Copy shown as typical layouts only, actual layouts to be determined and or verified prior to fabrication.
2. Sign installer to verify existing mounting conditions and use appropriate attachment method as per condition.
3. Braille shall be Calif Grade 2 (Contracted Braille).



ELEVATION HALF SIZE

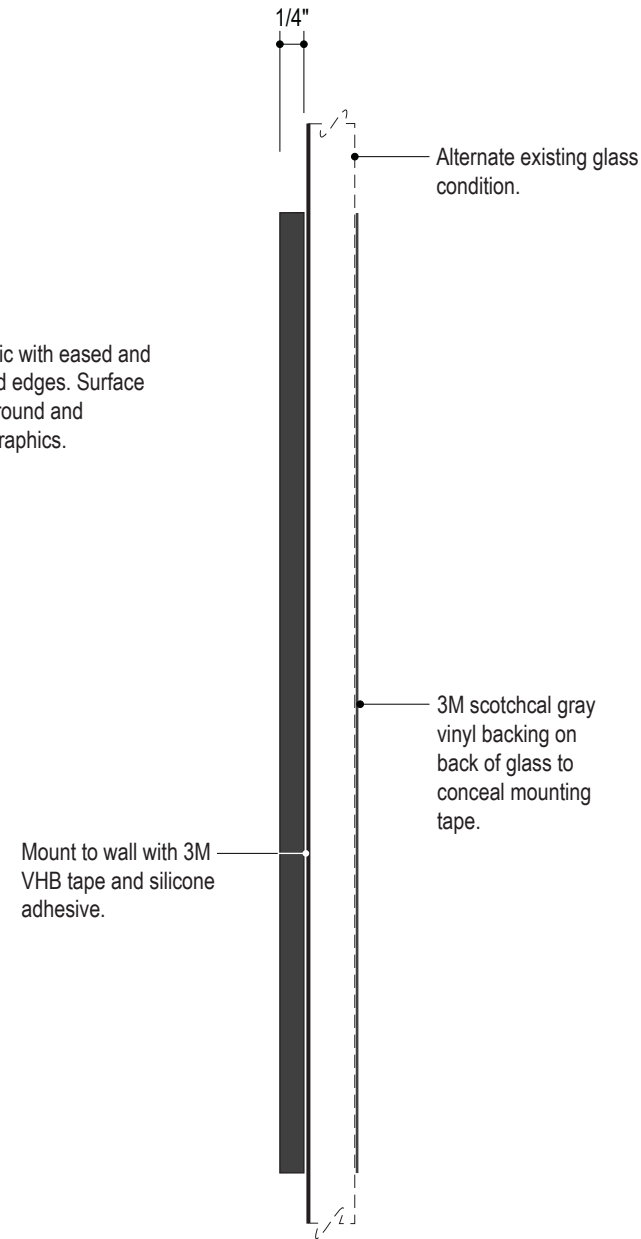

SIDE VIEW HALF SIZE

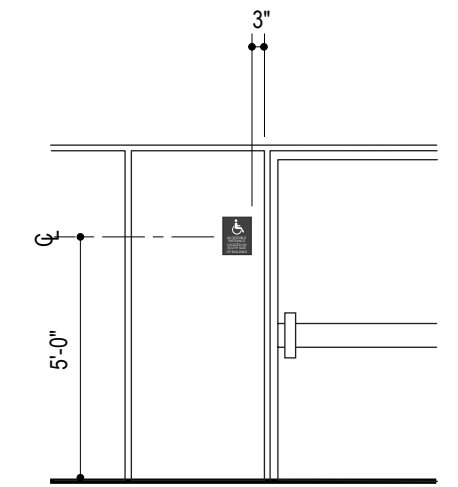

ALTERNATE GLASS MOUNTING 1/4"=1'-0"

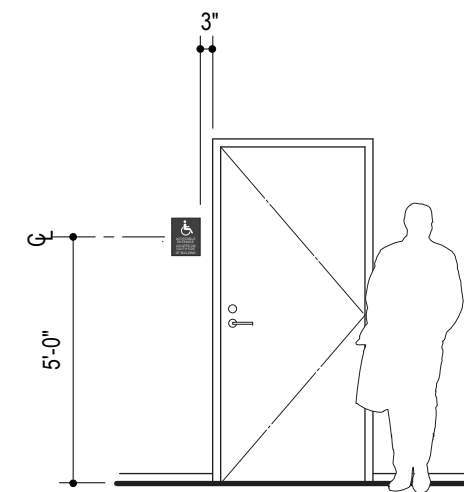

LOCATION ELEVATION 1/4"=1'-0"

GENERAL NOTES:

1. Copy shown as typical layouts only, actual layouts to be determined and or verified prior to fabrication.
2. Sign installer to verify existing mounting conditions and use appropriate attachment method as per condition.

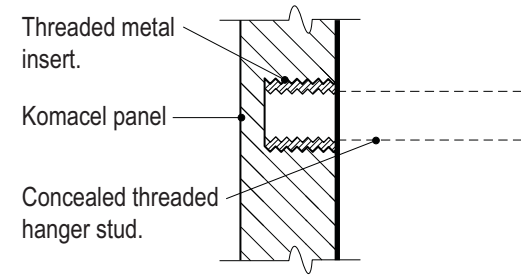

(A) DETAIL | FULL SIZE

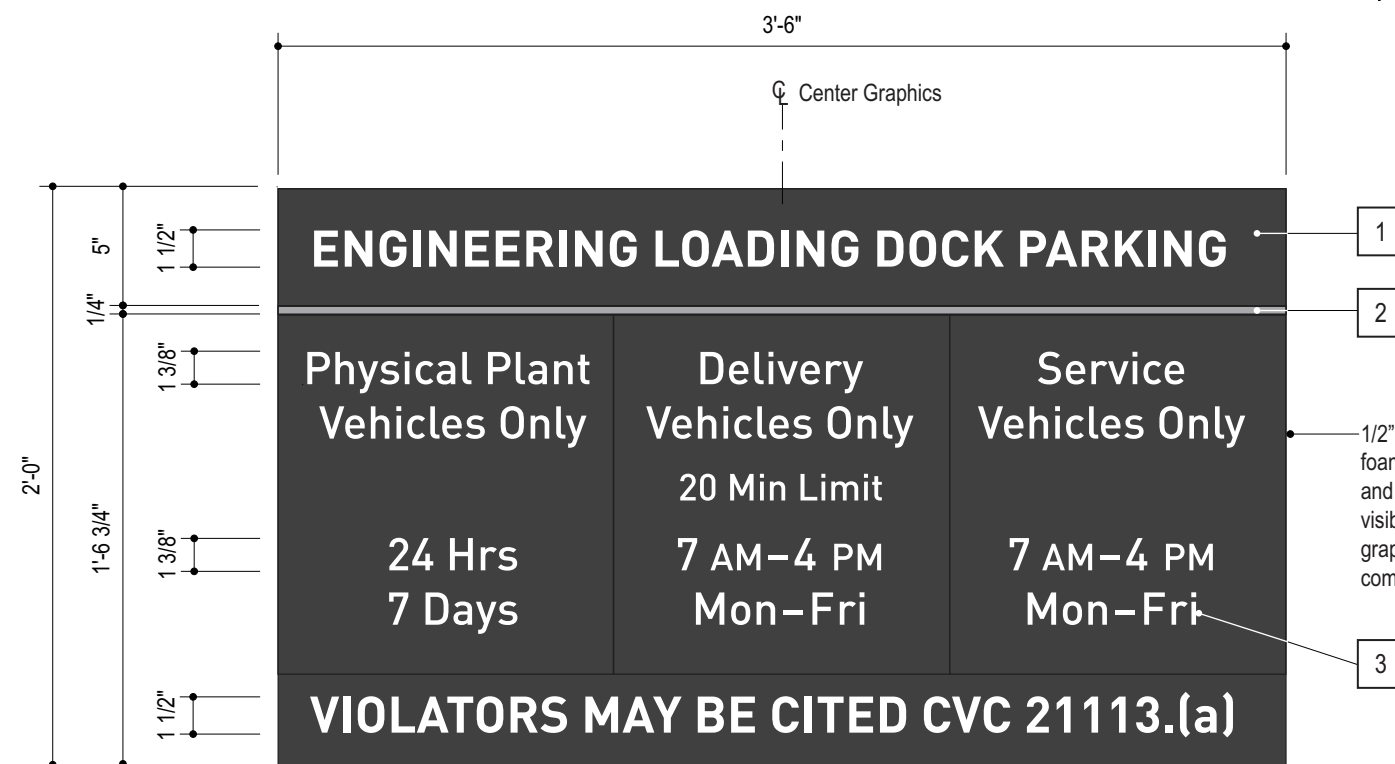

ELEVATION | 1 1/2"=1'-0"

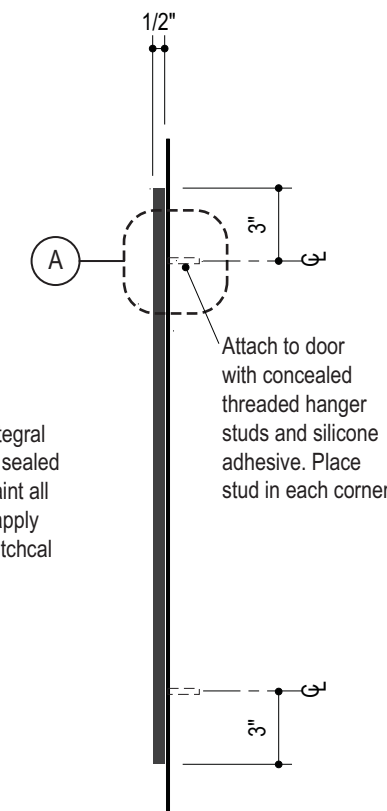

SIDE VIEW | 1 1/2"=1'-0"

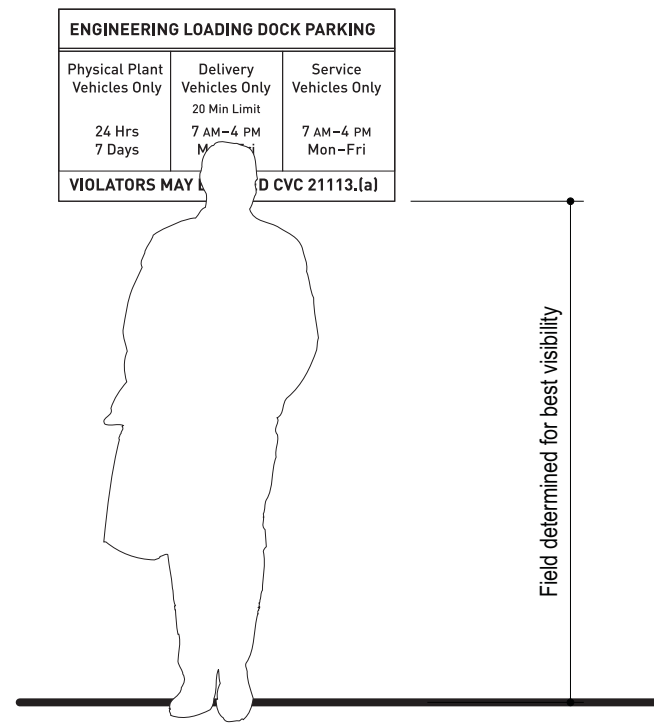

LOCATION ELEVATION | 1/2"=1'-0"

UCR Campus Process: Gender Inclusive Facilities 2015

ISSUING OFFICER: Associate Vice Chancellor/ Campus Architect

RESPONSIBLE OFFICE: Architects & Engineers **EFFECTIVE DATE:** November 01, 2015

I. Background

UCR is strongly committed to creating and sustaining a campus environment that supports and values all members of our community, including visitors. This Gender Inclusive Facilities process focuses on providing a safe environment, consistent with UCR principles of community and efforts aimed at civility and respect. Gender inclusion should provide access and equality by creating an environment that is safe, accessible and respectful of all individuals. One aspect of creating an inclusive environment is the availability of safe, accessible and convenient restroom facilities. Many people may experience difficulty, inconvenience or harassment when using gender specific restrooms and facilities. Additionally, parents with children of a different gender, as well as caregivers to persons of different genders, face difficulties in accompanying them. UCR aims to implement best practices for gender inclusive facilities.

II. Goals of the UCR Gender Inclusive Process

In accordance with the University's nondiscrimination policies, these guidelines seek to create an inclusive campus environment for transgender and gender variant people and provide direction on the implementation of gender inclusive facilities in UCR-owned buildings.

III. Definitions:

Changing Room: a room in which one or more persons partially or fully disrobe and re-dress. Locker rooms fall under this definition. Gender inclusive changing rooms shall provide privacy and security.

Gender Identity: an individual's sense of oneself as male, female or transgender, including an individual's self-image, appearance, expression or behavior, whether or not that self-image, appearance, expression or behavior is different from the individual's sex assigned at birth.

Gender Inclusive facility (sometimes referred to as Gender Neutral facility): a facility, including but not limited to restrooms, showers, locker rooms and changing rooms, that is

usable by persons of all gender identities and expressions and that is not gender specific. The facility shall provide privacy and security for the individual user. Gender inclusive facilities shall include spaces and fixtures equivalent to gender specific facilities.

Gender Specific: designated for use by one gender (i.e. male or female).

Restroom: any facility equipped with toilets, urinals and other similar facilities, in a public facility for use of the public for personal hygiene and comfort. “In a public facility” and “for use by the public” in this context covers essentially all UCR facilities and restrooms, except for facilities located within private residences or apartments, within dormitory suites, or in areas not accessible to the public.

Shower: a space in which one or more persons bathe or shower. Gender inclusive showers shall provide privacy and security for the individual user.

IV. **Applicability**

This process applies to UCR-owned facilities including new construction, existing and renovated facilities. While the process does not extend to UCR-leased facilities at this time, evaluation of the availability of gender inclusive facilities shall occur when beginning or renewing leases, especially when UCR leases more than 50% of a building, or for leases 10 years or longer. Privatized projects developed on UCR-owned land where the project is to be used for University-related purposes shall comply with the requirements for inclusive facilities.

V. **Process**

- a. **Existing Facilities: Capital Asset Strategies (CAS)** shall maintain an accurate list of Gender Inclusive Facilities in the campus space data found within the Facilities Management System (FMS). CAS will also maintain the locational listing in the Geographic Information System database, and transmit that information to Strategic Communications, for inclusion on the interactive campus map.

The Campus Architect will ensure the conversion of existing, single-occupancy or single-stall restrooms in UCR-owned buildings from gender specific to gender inclusive with privacy and security as noted in the definitions, such that all UCR-owned buildings with existing single stall restrooms will either contain a Gender Inclusive Restroom (GIRR) or be served by an identified GIRR in a “nearby” facility. “Nearby” is commonly defined as being within two minutes of pedestrian travel time between building entrances. Conversions will usually be limited to revised signage. Conversions that are accomplished by signage changes alone shall not be considered renovations. In cases

where conversions do not satisfy the goal of having a GIRR in every UCR-owned building or in a nearby building, construction or renovation of a GIRR must be considered.

- b. *New Construction or Renovation:*** UCR-owned buildings beginning design, for either new construction or renovation, on or after July 1, 2015, shall include at least one GIRR on each floor where restrooms are required or provided in a building. GIRRs on each floor shall be accessible consistent with the California Building Code (CBC). “UCR-owned” includes buildings designed and/or built by third parties that are to become the property of UCR upon completion.
- c. *Restroom Renovations:*** When extensive renovations are made to existing restrooms (i.e. when the construction cost for the renovation exceeds 50% of the restroom replacement cost) or when extensive renovations are made to one or more floors of an existing building (i.e. more than 50% of the replacement cost of the area being renovated) in buildings that do not already have at least one GIRR, the project shall provide a GIRR in the same building.
- d. *Changing Rooms:*** The design of new buildings shall provide for at least one gender-inclusive changing room in each location in the building where locker rooms or changing rooms are provided. The gender-inclusive changing room shall be located within the locker room/changing room facility so the user need not leave the locker room/changing room to use the gender-inclusive changing room. For major renovations, the Campus shall construct at least one gender inclusive private changing room in each location in any building where locker rooms or changing rooms are provided (major renovation is defined as renovation exceeding 50% of the replacement cost of the area being renovated) or when the locker room or changing room is renovated.
- e. *Showers:*** The design of new buildings shall provide for at least one gender-inclusive shower in buildings where showers are provided. If the shower or showers are located within a locker room/changing room facility, the gender inclusive shower(s) shall be located so that the user need not leave the locker room/changing room facility to use the shower. The Campus shall construct at least one gender inclusive shower in each location in any building where showers are provided when a major renovation occurs (major renovation is defined as renovation exceeding 50% of the replacement cost of the area being renovated) or when existing showers are renovated. The shower(s) shall be located within the locker room/changing room facility so that the user need not leave the locker room/changing room facility to use the shower(s).
- f. *Signage:*** Gender inclusive facilities will be identified in a simple manner, utilizing the minimum signage required by the CBC and the 2010 ADA Standards for Accessible Design (ADA). For GIRRs, the required sign on the door shall be a triangle within a circle

of contrasting color, without gender pictograms. The international convention is a white triangle on a blue circle, but ADA-compliant and CBC-compliant signs/colors are acceptable. The CBC-required room identification sign shall provide the minimum required information, including the pictogram for access, if applicable. For GIRRs, the room identification shall be "Restroom". Signs for changing rooms and shower rooms shall also follow this guidance, as applicable.

- g. Directional signs:** In existing buildings where gender inclusive facilities are not or cannot be provided, the Campus Architect shall direct the installation of at least one directional sign in a conspicuous location, normally near the building's main entrance and the building restrooms, indicating the location of the nearest gender inclusive facilities.
- h. Hardship:** In instances where hardship may preclude full compliance with this process, campus entities may request that a waiver from the process be approved. Approval authority for these waivers has been delegated in writing from the Chancellor to the Campus Building Official (Campus Architect). The waiver request form is included as Attachment A.
- i. Feedback:** Any concerns, suggestions, or recommendations associated with UCR's provision of gender inclusive facilities should be submitted to the Campus Architect, via the Office of Architects & Engineers.

VI. References

1. University of California Guidelines for Providing Gender Inclusive Facilities: Effective 7/1/15
2. University of California Facilities Manual RD4.1: Providing Gender Inclusive Facilities
3. UCR Gender Inclusive Facilities Hardship Waiver Request (Attachment A)
4. Model Template for Signs (Attachment B)

UCR Gender Inclusive Facilities Hardship Waiver Request

PROCESS

1. Project proponent completes Waiver Request Form. The Project Manager will provide technical support, as needed.
2. Request is submitted to Campus Building Official (Campus Architect) through the Architects & Engineers office.
3. Review of Request and application of criteria to be completed by “Working Group” consisting of:
 - a. Code Enforcement Representative
 - b. Capital Finance Representative
 - c. A&E Project Team member
 - d. CAS Project Team member
4. “Working Group” makes recommendation with justification to Campus Building Official for approval or denial.
5. Campus Building Official renders decision.
6. CBO decision may be appealed to VC-BAS, whose ruling will be final, and without further appeal.

CRITERIA

- **Building Code Compliance:** Waiver may be considered for instances where, in the judgement of the Campus Building Official (CBO), compliance with GIF provision would unduly compromise provisions of the California Building Code or other applicable provision of law.
 - Access
 - Life/Safety
 - Security
 - Fixture unit requirements(Plumbing Code)
- **Program impacts** – Waiver may be considered upon project proponent’s application where, in the judgement of the CBO, compliance with GIF provision would unduly compromise the core mission of the University by adverse impact on space or functional requirements of the facility.
- **Cost:** Waiver may be considered upon project proponent’s application where, in the judgement of the CBO, compliance with GIF provision would entail consumption of fiscal resources to a degree that would unduly compromise the core mission of the University.
 - Quantitative criteria:
 - For projects with a total budget (GIF compliance not included) of \$100,000 or less, cost impact >10%.
 - For projects with a total budget (GIF compliance not included) of >\$100,000 cost impact >5%.
- **Location:** Waiver may be considered upon application where, in the judgement of the CBO, compliance with GIF provision is unnecessary based on availability of convenient access to existing GIF facility.

**Gender Inclusive Facilities in Renovation Projects
REQUEST FOR WAIVER BASED ON HARDSHIP**

Submit completed form to UCR Architects and Engineers office

LEGEND

Input cell
Calculation

Campus

Project

Date

PROJECT COST

Construction cost of overall project
 Construction cost of inclusive restroom work (new or remodeled single-occupancy restroom or remodeled multi-occupancy restroom)
 Percentage of restroom cost/overall project construction cost

\$

\$

OCCUPANT LOAD & FIXTURE COUNTS

Occupant load of building

Occupants

MEN		WOMEN	
TOILETS & URINALS	LAVATORIES	TOILETS	LAVATORIES
<input style="width: 80px; height: 20px;" type="text"/>	<input style="width: 80px; height: 20px;" type="text"/>	<input style="width: 80px; height: 20px;" type="text"/>	<input style="width: 80px; height: 20px;" type="text"/>
<input style="width: 80px; height: 20px;" type="text"/>	<input style="width: 80px; height: 20px;" type="text"/>	<input style="width: 80px; height: 20px;" type="text"/>	<input style="width: 80px; height: 20px;" type="text"/>
<input style="width: 80px; height: 20px;" type="text"/>	<input style="width: 80px; height: 20px;" type="text"/>	<input style="width: 80px; height: 20px;" type="text"/>	<input style="width: 80px; height: 20px;" type="text"/>
<input style="width: 80px; height: 20px;" type="text"/>	<input style="width: 80px; height: 20px;" type="text"/>	<input style="width: 80px; height: 20px;" type="text"/>	<input style="width: 80px; height: 20px;" type="text"/>

^{1,2,4} **Required** number of gender specific toilet/urinal fixtures
Existing number of gender specific toilet/urinal fixtures
 Number of gender specific fixtures inc. new inclusive restroom(s)
 Deficit (if any) with new inclusive restrooms and fixtures

PROXIMITY

Are there other inclusive restrooms in this building?
 If YES, indicate distance to nearest inclusive restroom in building
³ If NO, indicate location of nearest inclusive restroom

YES or NO			
<input style="width: 80px; height: 20px;" type="text"/>	Travel distance in feet	<input style="width: 80px; height: 20px;" type="text"/>	Travel distance--number of floors
<input style="width: 80px; height: 20px;" type="text"/>	Travel distance in feet between building entries	<input style="width: 80px; height: 20px;" type="text"/>	Pedestrian travel time between building entries

HARDSHIP

If space will be reassigned from programmatic or other dedicated use to construct the inclusive restroom(s), describe secondary effects of constructing restroom in this location

(Describe)

INTENT

If inclusive restroom cannot be provided in this location, describe the proposed alternate solution and how it meets the spirit and intent of the inclusive restrooms guidelines?

(Describe)

NOTES

¹ "Separate" refers to California Code of Regulations, Title 24, Part 6--California Plumbing Code, Section 422.2, Separate Facilities: "Separate toilet facilities shall be provided for each sex." See also Table 422.1 of the plumbing code for fixture count requirements.
² Include additional code-triggered required separate fixtures that must be added by the work of the new project, if any.
³ Pedestrian travel time is encouraged to be less than 2 minutes between building entrances to avoid extending break times and provide equivalent facilities
⁴ Modify form as needed if assessing changing rooms or showers

Signage Guidelines - Gender Inclusive Facilities

Updated 6/23/2020



Directional Signage – to be used if no gender inclusive facilities are available in a building.



Restroom Door Sign – Details on Page 2



Restroom Room Sign – Details on Page 3

All signs shall meet ADA and CBC Standards.

CBC/ADA Door Signage

SIGN SPECIFICATIONS

1. SIGN PANEL SUBSTRATE
 Finish Size: 9"H x 10 1/2"W
 Material: 1/4" Plaskolite Non-Glare Clear Acrylic (P99)
 Backpaint: Matthews Paint to Match 311-307 Charcoal Grey (Satin Finish)
 Edge Finish: Milled & Unpainted

2. SIGN PANEL SUBSTRATE
 Finish Size: 12"H x 12"W
 Material: 1/4" Plaskolite Non-Glare Clear Acrylic (P99)
 Backpaint: Matthews MAP-LVS202 White (Satin Finish)
 Edge Finish: Milled & Unpainted

3. SYMBOL
 Material: Second-Surface Vinyl To Match 311-307 Charcoal Grey (Opaque)
 Height: 5 1/2" Tall

4. SYMBOL
 Material: Second-Surface 3M #7725-10 Opaque White Vinyl
 Height: 5 1/2" Tall

5. ADHESIVE / TAPE FOR COMPONENTS
 Tape: Thin DT Tape

6. MOUNTING
 Tape: 1/16" Thick Double Sided Foam Tape & Silicone Adhesive

INSTALLATION PLACEMENT
 Height: 60" Bottom of Highest Tactile Letters / 48" AFF Min. to Bottom of Braille
 Placement: 9" OC of Tactile Characters From Opening of Door
 Location: Adjacent to Latch Side of Door. Refer to CSB Installation Standards

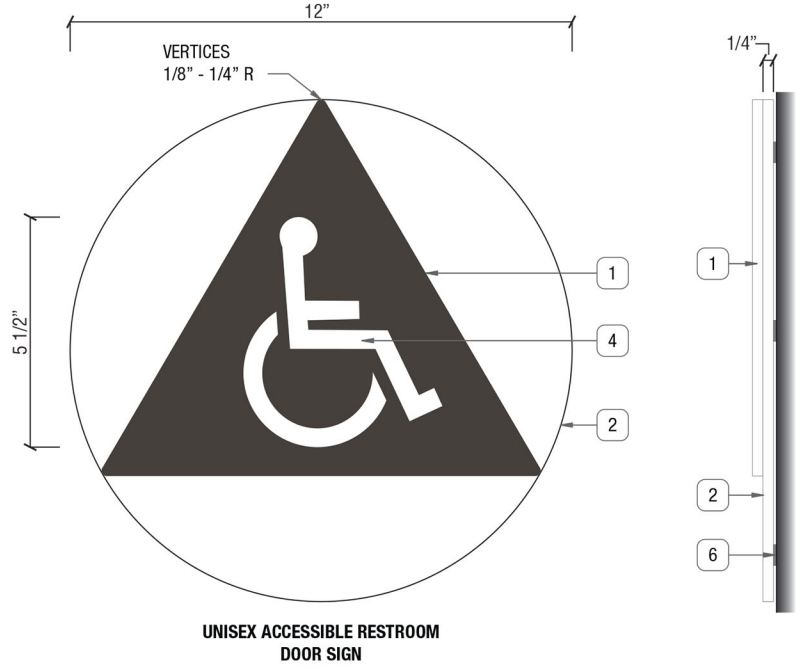

SIGN TYPE - GENDER INCLUSIVE RESTROOM

B SIDE VIEW
 SCALE: 3" = 1'-0"

COLOR LEGEND

	WHITE - MATTHEWS PAINT MAP-LVS202 (SATIN FINISH) / 3M #7725-10 OPAQUE WHITE VINYL
	CHARCOAL GREY - 311-307 CHARCOAL GREY - VINYL / MATTHEWS PAINT TO MATCH (SATIN FINISH)

Restroom Signage (Wall Mt.)

SIGN SPECIFICATIONS

1. SIGN PANEL SUBSTRATE

Finish Size: 6 1/4"H x 10"W
 Material: 1/4" Plaskolite Non-Glare Clear Acrylic (P99)
 Backpaint: Matthews MAP-LVS202 White (Satin Finish)
 Edge Finish: Milled & Unpainted

2. TACTILE APPLIQUE

Material: Modified Acrylic
 Font Height: 5/8" Tall
 Symbol Heights: 4 1/2" / 2 7/8"
 Depth: 1/32" Thick
 Font: DIN Medium
 Color: 311-307 Charcoal Grey

3. BRAILLE

Type: Clear Grade II Braille

4. DECORATIVE METAL BAR

Material: 6063 Aluminum Square 1/4" x 10"
 Finish: #4 Brushed Finish (Horizontal Grain)
 Fastener: Thin DT Tape

5. ADHESIVE / TAPE FOR COMPONENTS

Tape: Thin DT Tape

6. MOUNTING

Tape: 1/16" Thick Double Sided Foam Tape & Silicone Adhesive

INSTALLATION PLACEMENT

Height: 60" Bottom of Highest Tactile Letters / 48" AFF Min. to Bottom of Braille
 Placement: 9" OC of Tactile Characters From Opening of Door
 Location: Adjacent to Latch Side of Door. Refer to CSB Installation Standards



QTY. : 2

TOTAL QTY. : 8

A ELEVATION
 SCALE: HALF-SIZE

SIGN TYPE - GENDER INCLUSIVE
 RESTROOM

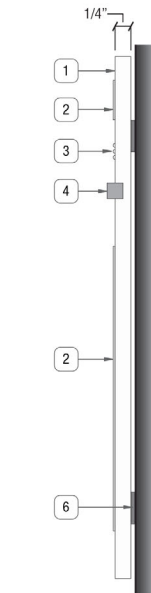

B SIDE VIEW
 SCALE: HALF-SIZE

COLOR LEGEND

- WHITE - MATTHEWS PAINT MAP-LVS202 (SATIN FINISH)
- CHARCOAL GREY - TACTILE: 311-307 CHARCOAL GREY / MATTHEWS PAINT TO MATCH (SATIN FINISH)
- #4 BRUSHED FINISH (HORIZONTAL GRAIN)

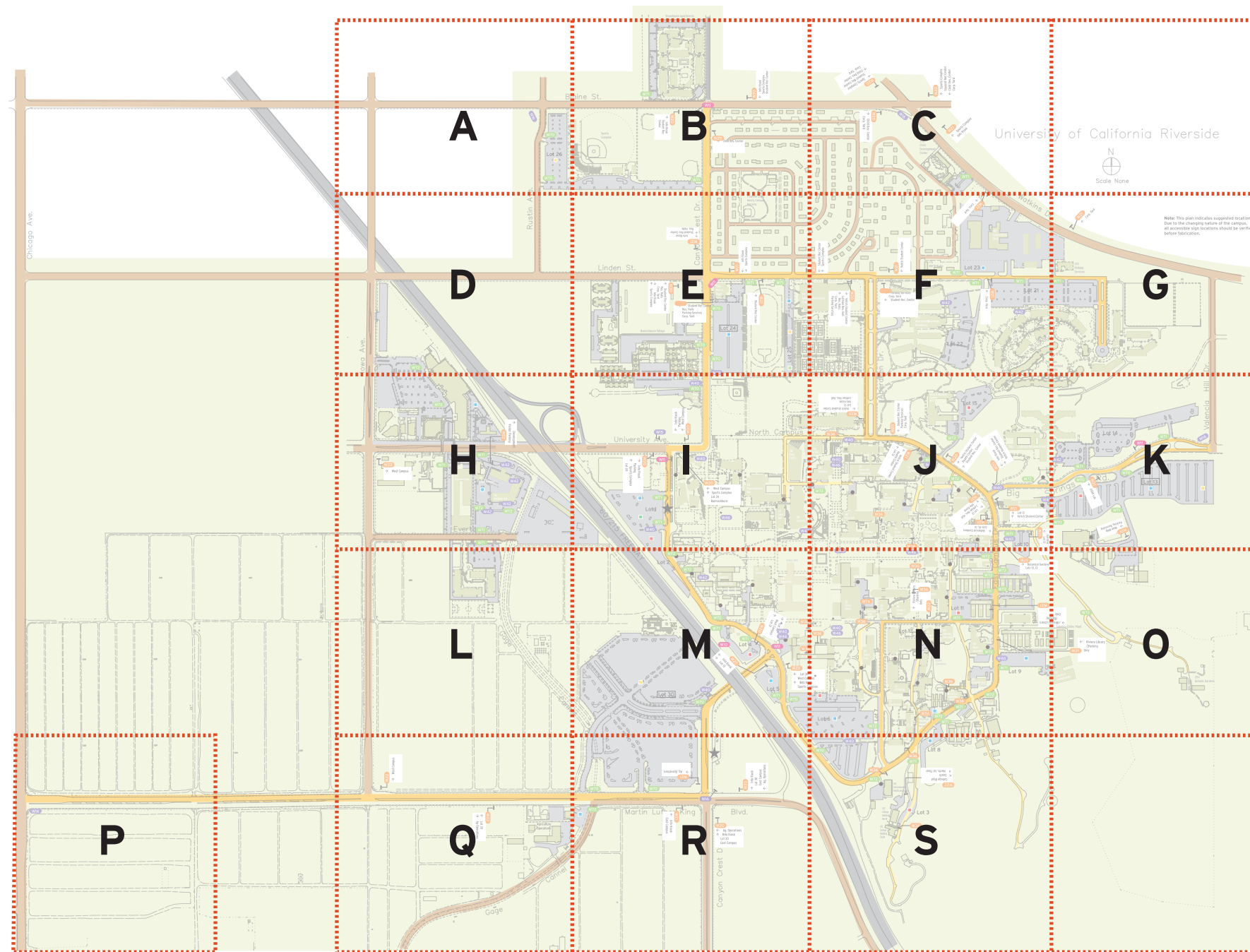

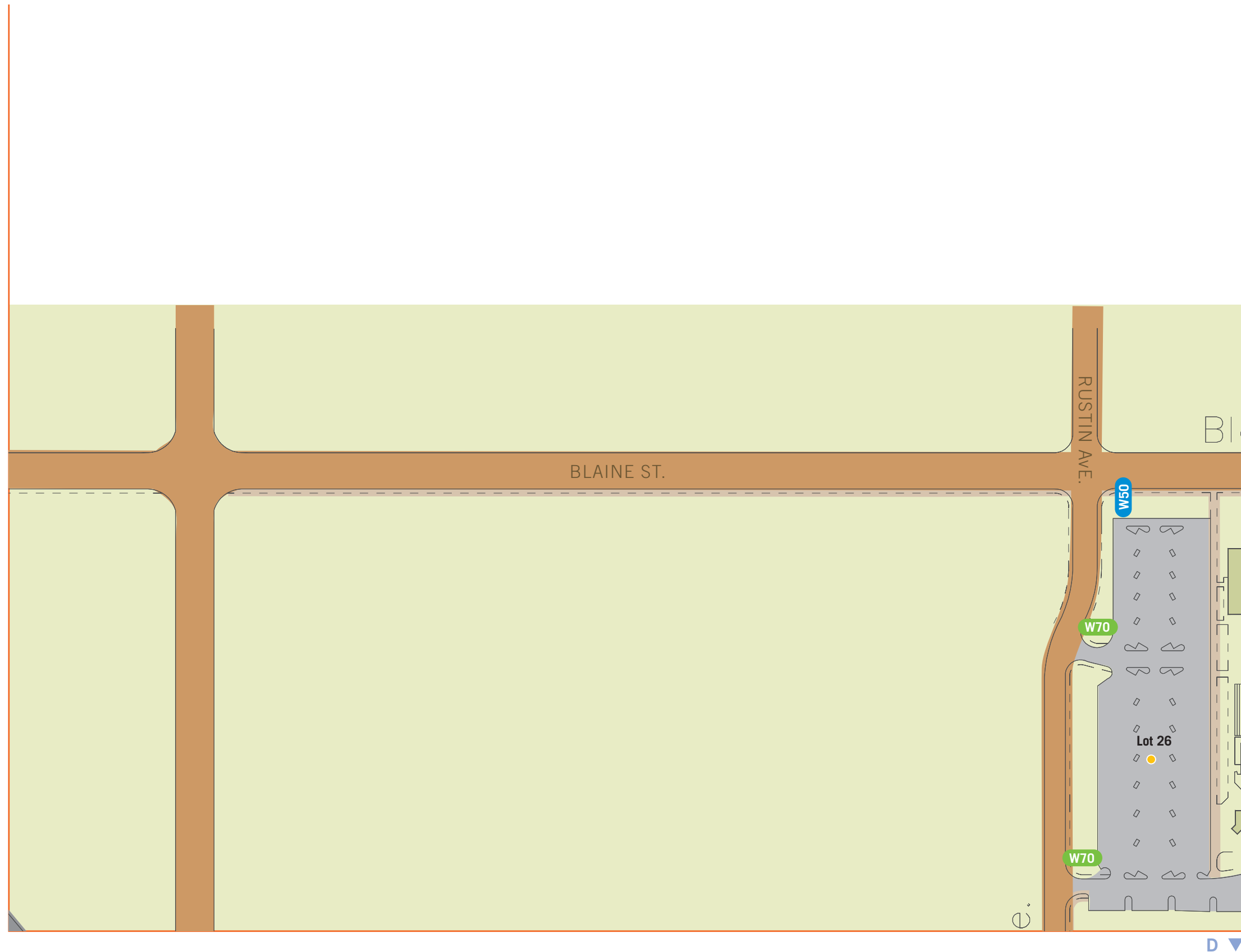

- Legend**
- Off campus vehicular circulation
 - On campus primary veh. circulation
 - On campus secondary veh. circulation
 - Primary Pedestrian Circulation
 - Secondary Pedestrian Circulation
 - Parking Lot Permit Zones
 - ★ Information Kiosk
 - ▲ Existing Postings
 - Electronic Message Boards**
W10 Site ID, Freeway
W11 Campus ID
 - Campus Entry Monument**
W15 Primary ID
W16 Secondary ID
 - Pedestrian Information**
W36 Accessible Pathway
 - Pedestrian Information**
W40 Freestanding Directory, primary
W41 Wall Mounted Directory
W42 Freestanding Directory, secondary
W46 Info Kiosk, Posted Messages
W48 Interactive Kiosk
 - Building Identity**
W50 Primary, vehicular
W51 Freestanding, Ped
 - Parking Lot Id/Info**
W70 Primary ID
W71 Secondary ID
W72 Pole Mounted ID
 - W97 Street Signs

Note:
Lozenge orientation does not necessarily represent accurate sign placement.

A ◀



- Legend**
- Off campus vehicular circulation
 - On campus primary veh. circulation
 - On campus secondary veh. circulation
 - Primary Pedestrian Circulation
 - Secondary Pedestrian Circulation
 - Parking Lot Permit Zones
 - Information Kiosk
 - Existing Postings
 - Electronic Message Boards**
W10 Site ID, Freeway
W11 Campus ID
 - Campus Entry Monument**
W15 Primary ID
W16 Secondary ID
 - Pedestrian Information**
W36 Accessible Pathway
 - Pedestrian Information**
W40 Freestanding Directory, primary
W41 Wall Mounted Directory
W42 Freestanding Directory, secondary
W46 Info Kiosk, Posted Messages
W48 Interactive Kiosk
 - Building Identity**
W50 Primary, vehicular
W51 Freestanding, Ped
 - Parking Lot Id/Info**
W70 Primary ID
W71 Secondary ID
W72 Pole Mounted ID
 - W97 Street Signs

Note:
Lozenge orientation does not necessarily represent accurate sign placement.

▶ C
E ▼

B ◀



Universi

- Legend**
- Off campus vehicular circulation
 - On campus primary veh. circulation
 - On campus secondary veh. circulation
 - Primary Pedestrian Circulation
 - Secondary Pedestrian Circulation
 - Parking Lot Permit Zones
 - Information Kiosk
 - Existing Postings
 - Electronic Message Boards**
W10 Site ID, Freeway
W11 Campus ID
 - Campus Entry Monument**
W15 Primary ID
W16 Secondary ID
 - Pedestrian Information**
W36 Accessible Pathway
 - Pedestrian Information**
W40 Freestanding Directory, primary
W41 Wall Mounted Directory
W42 Freestanding Directory, secondary
W46 Info Kiosk, Posted Messages
W48 Interactive Kiosk
 - Building Identity**
W50 Primary, vehicular
W51 Freestanding, Ped
 - Parking Lot Id/Info**
W70 Primary ID
W71 Secondary ID
W72 Pole Mounted ID
 - W97 Street Signs

Note:
Lozenge orientation does not necessarily represent accurate sign placement.

F ▼

▲ A

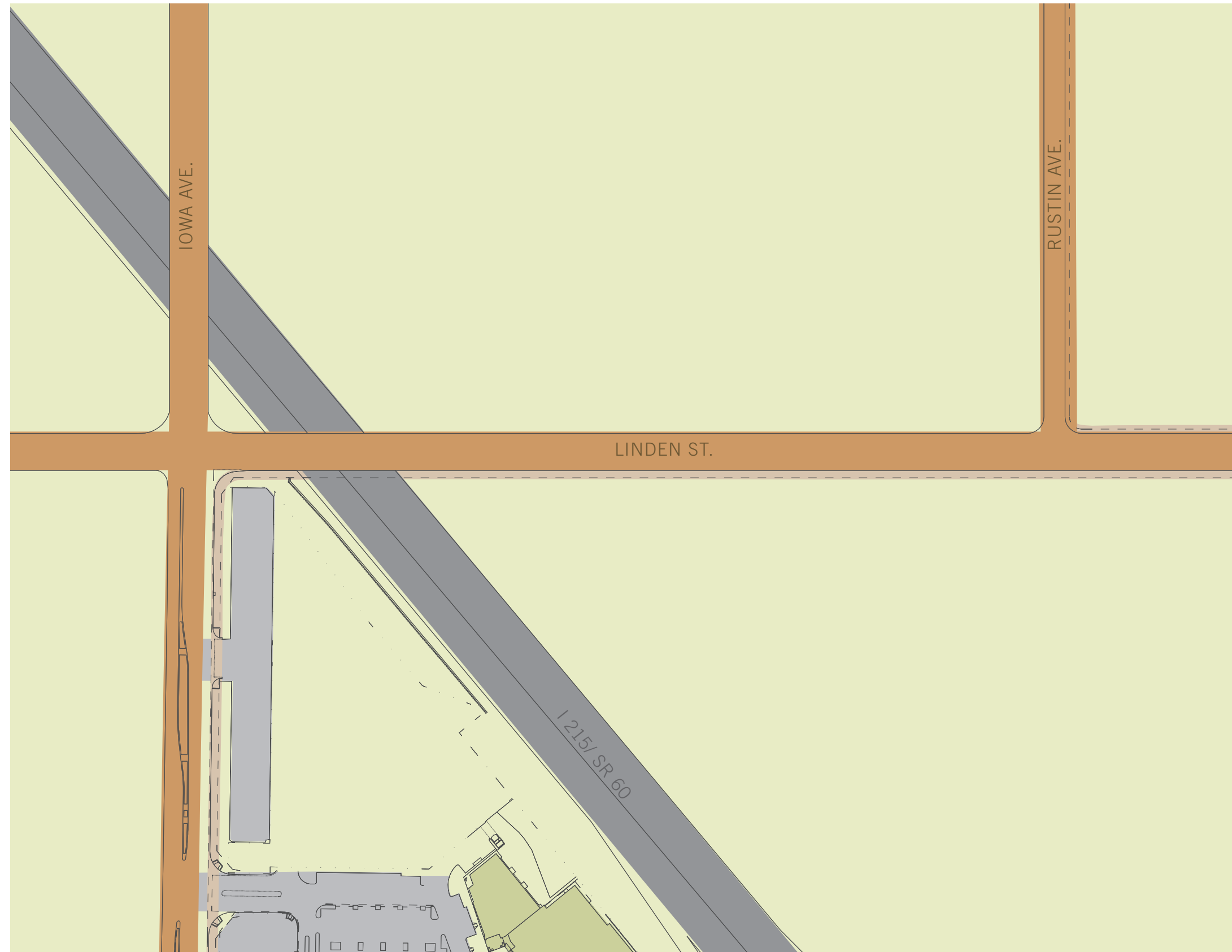

H ▼ E

- Legend**
- Off campus vehicular circulation
 - On campus primary veh. circulation
 - On campus secondary veh. circulation
 - Primary Pedestrian Circulation
 - Secondary Pedestrian Circulation
 - Parking Lot Permit Zones
 - Information Kiosk
 - Existing Postings
 - Electronic Message Boards**
W10 Site ID, Freeway
W11 Campus ID
 - Campus Entry Monument**
W15 Primary ID
W16 Secondary ID
 - Pedestrian Information**
W36 Accessible Pathway
 - Pedestrian Information**
W40 Freestanding Directory, primary
W41 Wall Mounted Directory
W42 Freestanding Directory, secondary
W46 Info Kiosk, Posted Messages
W48 Interactive Kiosk
 - Building Identity**
W50 Primary, vehicular
W51 Freestanding, Ped
 - Parking Lot Id/Info**
W70 Primary ID
W71 Secondary ID
W72 Pole Mounted ID
 - W97 Street Signs

Note:
Lozenge orientation does not necessarily represent accurate sign placement.

▲ B
D ◀



- Legend**
- Off campus vehicular circulation
 - On campus primary veh. circulation
 - On campus secondary veh. circulation
 - Primary Pedestrian Circulation
 - Secondary Pedestrian Circulation
 - Parking Lot Permit Zones
 - ★ Information Kiosk
 - ▲ Existing Postings
 - Electronic Message Boards**
W10 Site ID, Freeway
W11 Campus ID
 - Campus Entry Monument**
W15 Primary ID
W16 Secondary ID
 - Pedestrian Information**
W36 Accessible Pathway
 - Pedestrian Information**
W40 Freestanding Directory, primary
W41 Wall Mounted Directory
W42 Freestanding Directory, secondary
W46 Info Kiosk, Posted Messages
W48 Interactive Kiosk
 - Building Identity**
W50 Primary, vehicular
W51 Freestanding, Ped
 - Parking Lot Id/Info**
W70 Primary ID
W71 Secondary ID
W72 Pole Mounted ID
 - W97 Street Signs

Note:
Lozenge orientation does not necessarily represent accurate sign placement.

▶ F
I ▼

E

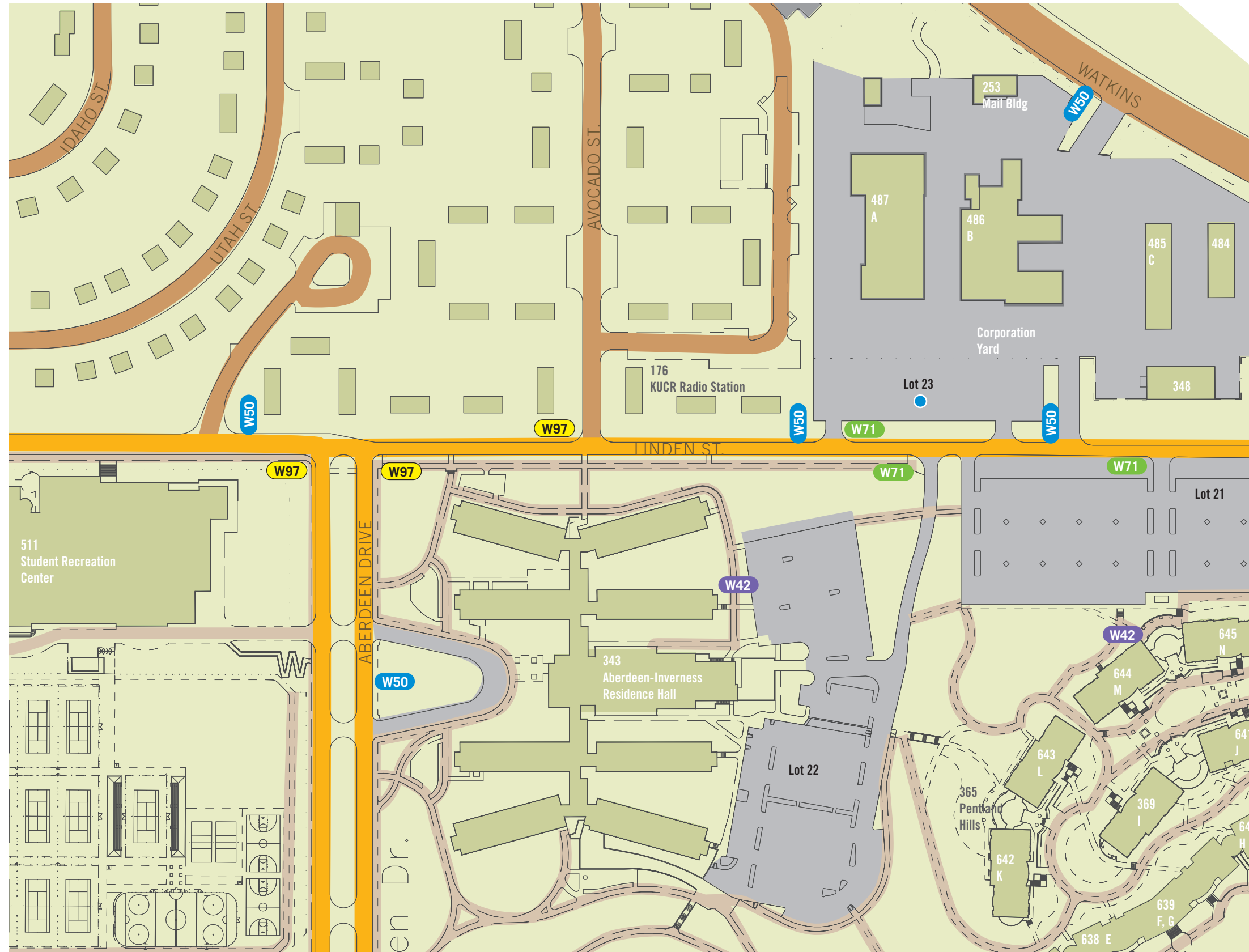

- Legend**
- Off campus vehicular circulation
 - On campus primary veh. circulation
 - On campus secondary veh. circulation
 - Primary Pedestrian Circulation
 - Secondary Pedestrian Circulation
 - Parking Lot Permit Zones
 - Information Kiosk
 - Existing Postings
 - Electronic Message Boards**
W10 Site ID, Freeway
W11 Campus ID
 - Campus Entry Monument**
W15 Primary ID
W16 Secondary ID
 - Pedestrian Information**
W36 Accessible Pathway
 - Pedestrian Information**
W40 Freestanding Directory, primary
W41 Wall Mounted Directory
W42 Freestanding Directory, secondary
W46 Info Kiosk, Posted Messages
W48 Interactive Kiosk
 - Building Identity**
W50 Primary, vehicular
W51 Freestanding, Ped
 - Parking Lot Id/Info**
W70 Primary ID
W71 Secondary ID
W72 Pole Mounted ID
 - W97 Street Signs

Note:
Lozenge orientation does not necessarily represent accurate sign placement.

J

F ◀

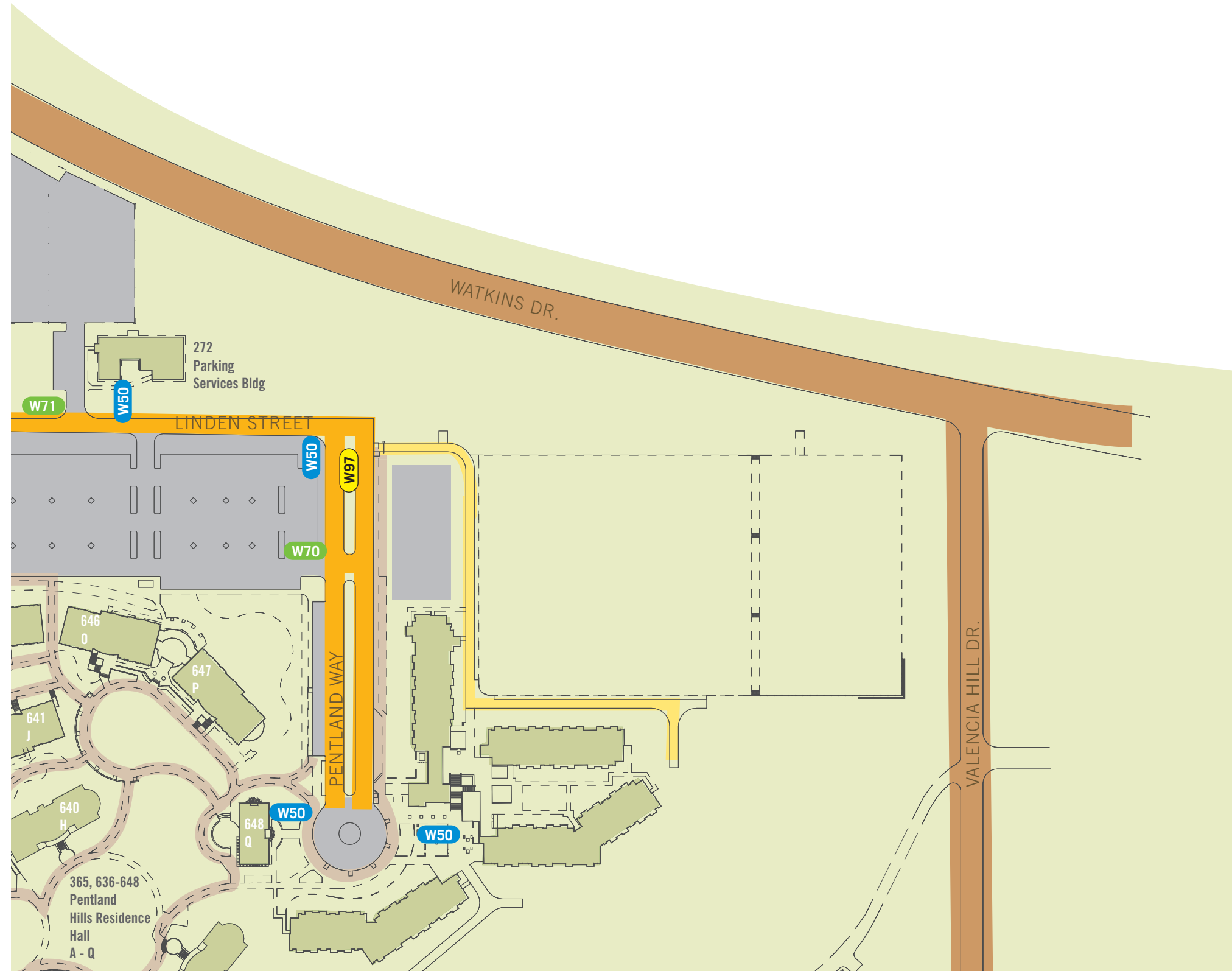

Legend

- Off campus vehicular circulation
- On campus primary veh. circulation
- On campus secondary veh. circulation
- Primary Pedestrian Circulation
- Secondary Pedestrian Circulation
- Parking Lot Permit Zones
- ★ Information Kiosk
- ▲ Existing Postings
- Electronic Message Boards**
W10 Site ID, Freeway
W11 Campus ID
- Campus Entry Monument**
W15 Primary ID
W16 Secondary ID
- Pedestrian Information**
W36 Accessible Pathway
- Pedestrian Information**
W40 Freestanding Directory, primary
W41 Wall Mounted Directory
W42 Freestanding Directory, secondary
W46 Info Kiosk, Posted Messages
W48 Interactive Kiosk
- Building Identity**
W50 Primary, vehicular
W51 Freestanding, Ped
- Parking Lot Id/Info**
W70 Primary ID
W71 Secondary ID
W72 Pole Mounted ID
- W97 Street Signs

Note:
Lozenge orientation does not necessarily represent accurate sign placement.

K ▼

▲ D

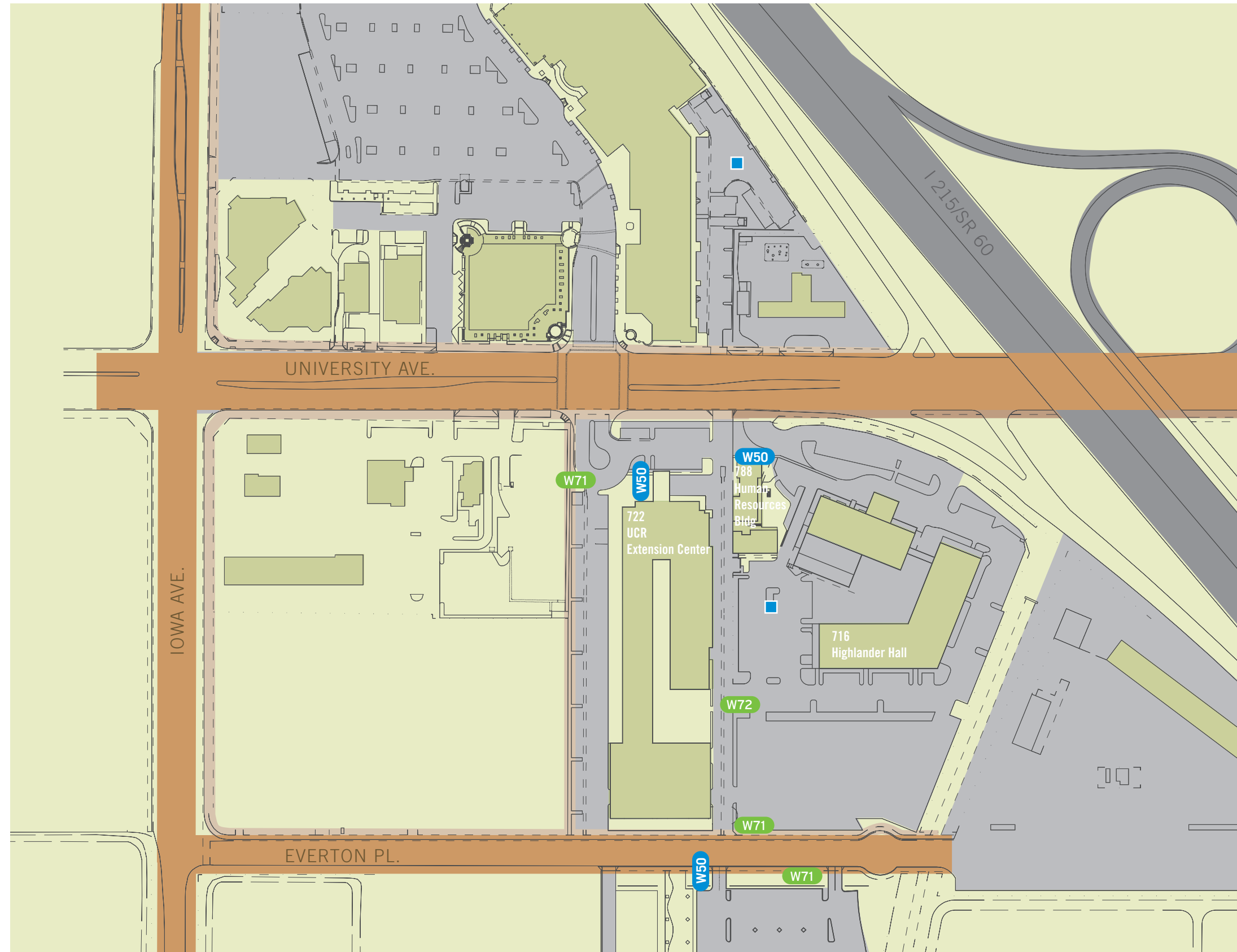

- Legend**
- Off campus vehicular circulation
 - On campus primary veh. circulation
 - On campus secondary veh. circulation
 - Primary Pedestrian Circulation
 - Secondary Pedestrian Circulation
 - Parking Lot Permit Zones
 - Information Kiosk
 - Existing Postings
 - Electronic Message Boards**
W10 Site ID, Freeway
W11 Campus ID
 - Campus Entry Monument**
W15 Primary ID
W16 Secondary ID
 - Pedestrian Information**
W36 Accessible Pathway
 - Pedestrian Information**
W40 Freestanding Directory, primary
W41 Wall Mounted Directory
W42 Freestanding Directory, secondary
W46 Info Kiosk, Posted Messages
W48 Interactive Kiosk
 - Building Identity**
W50 Primary, vehicular
W51 Freestanding, Ped
 - Parking Lot Id/Info**
W70 Primary ID
W71 Secondary ID
W72 Pole Mounted ID
 - W97 Street Signs

Note:
Lozenge orientation does not necessarily represent accurate sign placement.

▶ I
L ▼

H ▲ E
H ◀



- Legend**
- Off campus vehicular circulation
 - On campus primary veh. circulation
 - On campus secondary veh. circulation
 - Primary Pedestrian Circulation
 - Secondary Pedestrian Circulation
 - Parking Lot Permit Zones
 - Information Kiosk
 - Existing Postings
 - Electronic Message Boards**
W10 Site ID, Freeway
W11 Campus ID
 - Campus Entry Monument**
W15 Primary ID
W16 Secondary ID
 - Pedestrian Information**
W36 Accessible Pathway
 - Pedestrian Information**
W40 Freestanding Directory, primary
W41 Wall Mounted Directory
W42 Freestanding Directory, secondary
W46 Info Kiosk, Posted Messages
W48 Interactive Kiosk
 - Building Identity**
W50 Primary, vehicular
W51 Freestanding, Ped
 - Parking Lot Id/Info**
W70 Primary ID
W71 Secondary ID
W72 Pole Mounted ID
 - W97 Street Signs

Note:
Lozenge orientation does not necessarily represent accurate sign placement.

▶ J
M ▼



- Legend**
- Off campus vehicular circulation
 - On campus primary veh. circulation
 - On campus secondary veh. circulation
 - Primary Pedestrian Circulation
 - Secondary Pedestrian Circulation
 - Parking Lot Permit Zones
 - Information Kiosk
 - Existing Postings
 - Electronic Message Boards**
W10 Site ID, Freeway
W11 Campus ID
 - Campus Entry Monument**
W15 Primary ID
W16 Secondary ID
 - Pedestrian Information**
W36 Accessible Pathway
 - Pedestrian Information**
W40 Freestanding Directory, primary
W41 Wall Mounted Directory
W42 Freestanding Directory, secondary
W46 Info Kiosk, Posted Messages
W48 Interactive Kiosk
 - Building Identity**
W50 Primary, vehicular
W51 Freestanding, Ped
 - Parking Lot Id/Info**
W70 Primary ID
W71 Secondary ID
W72 Pole Mounted ID
 - W97 Street Signs

Note:
Lozenge orientation does not necessarily represent accurate sign placement.

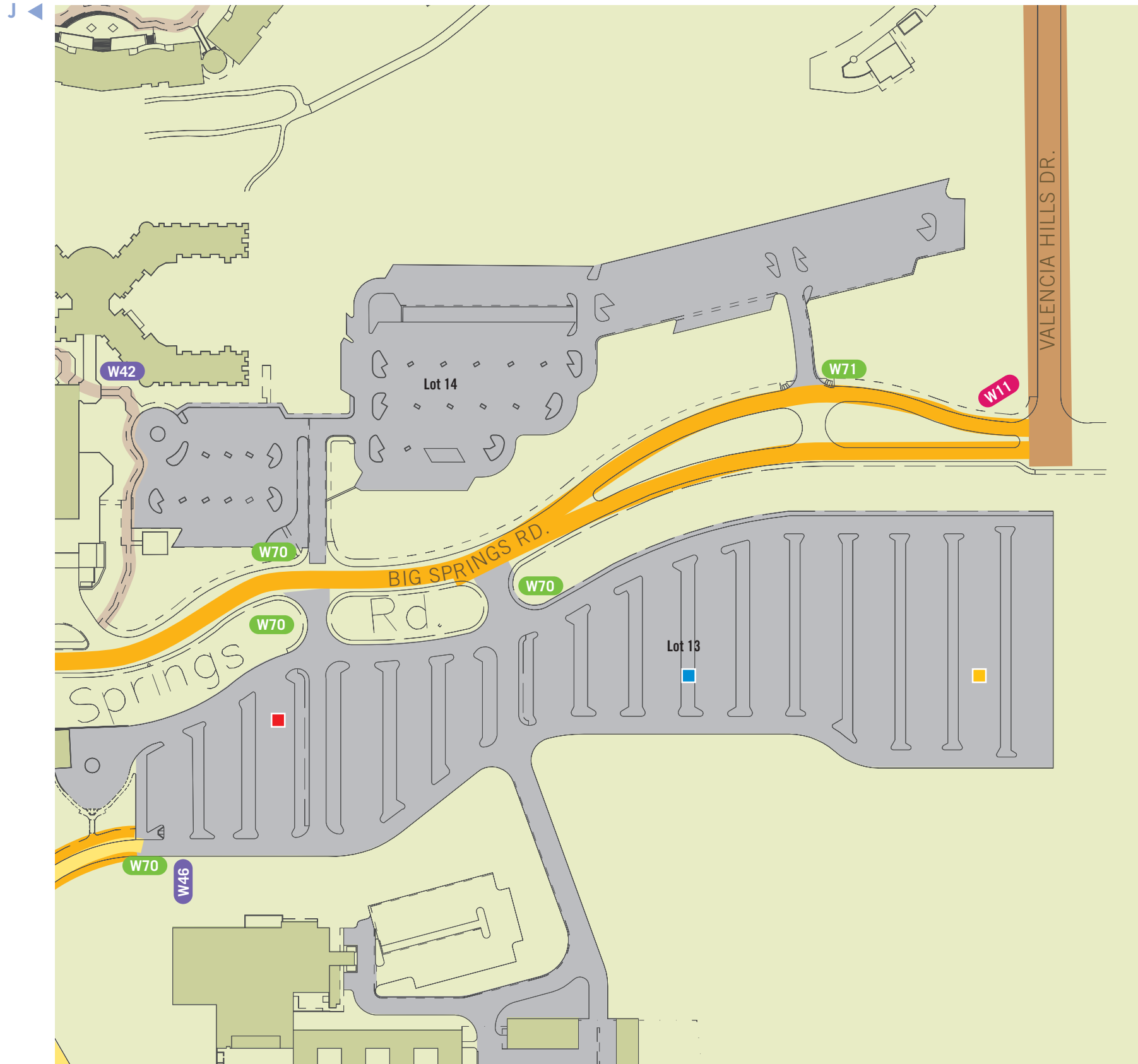

- Legend**
- Off campus vehicular circulation
 - On campus primary veh. circulation
 - On campus secondary veh. circulation
 - Primary Pedestrian Circulation
 - Secondary Pedestrian Circulation
 - Parking Lot Permit Zones
 - ★ Information Kiosk
 - ▲ Existing Postings
 - Electronic Message Boards**
W10 Site ID, Freeway
W11 Campus ID
 - Campus Entry Monument**
W15 Primary ID
W16 Secondary ID
 - Pedestrian Information**
W36 Accessible Pathway
 - Pedestrian Information**
W40 Freestanding Directory, primary
W41 Wall Mounted Directory
W42 Freestanding Directory, secondary
W46 Info Kiosk, Posted Messages
W48 Interactive Kiosk
 - Building Identity**
W50 Primary, vehicular
W51 Freestanding, Ped
 - Parking Lot Id/Info**
W70 Primary ID
W71 Secondary ID
W72 Pole Mounted ID
 - W97 Street Signs

Note:
Lozenge orientation does not necessarily represent accurate sign placement.

▲ H

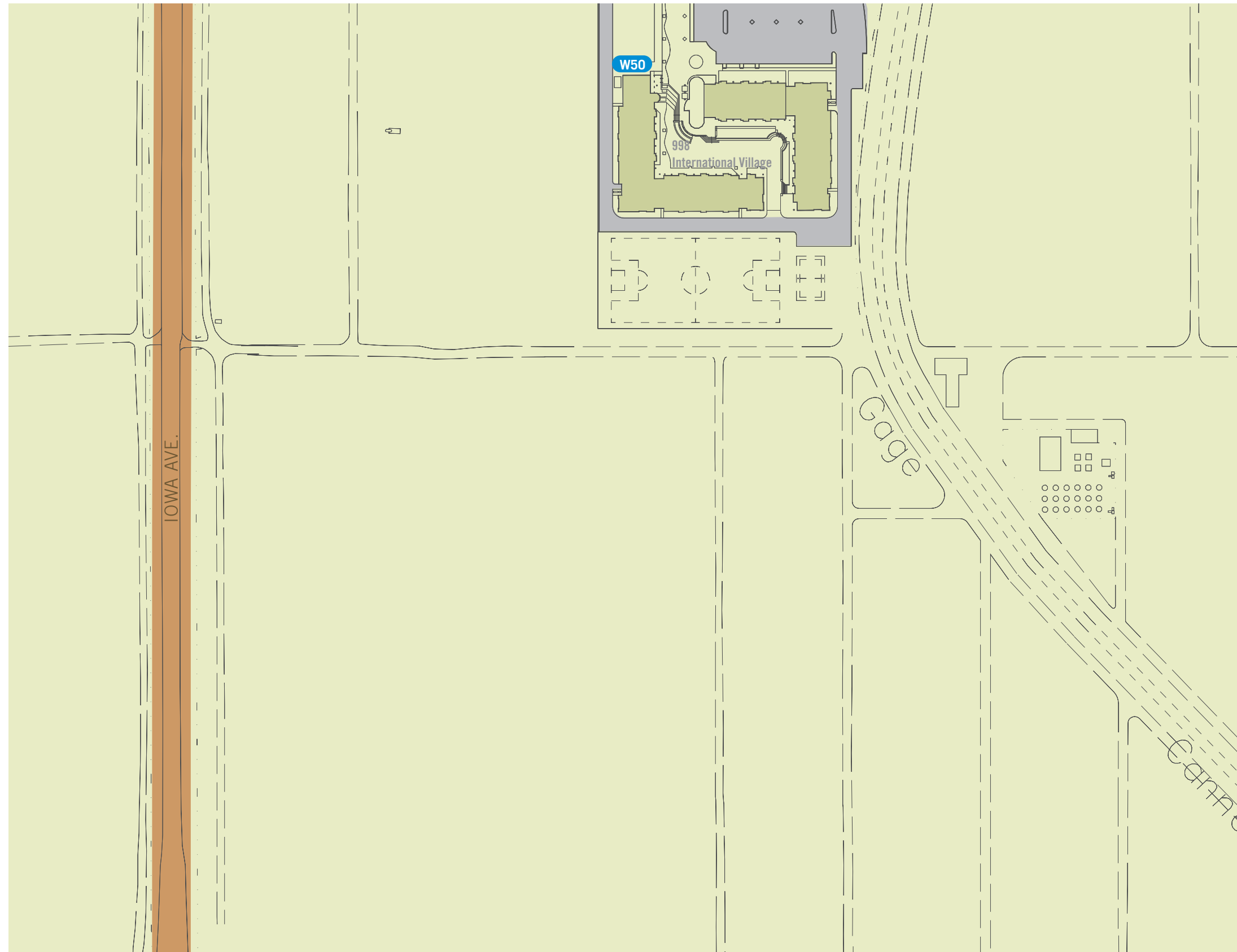

- Legend**
- Off campus vehicular circulation
 - On campus primary veh. circulation
 - On campus secondary veh. circulation
 - Primary Pedestrian Circulation
 - Secondary Pedestrian Circulation
 - Parking Lot Permit Zones
 - ★ Information Kiosk
 - ▲ Existing Postings
 - Electronic Message Boards**
W10 Site ID, Freeway
W11 Campus ID
 - Campus Entry Monument**
W15 Primary ID
W16 Secondary ID
 - Pedestrian Information**
W36 Accessible Pathway
 - Pedestrian Information**
W40 Freestanding Directory, primary
W41 Wall Mounted Directory
W42 Freestanding Directory, secondary
W46 Info Kiosk, Posted Messages
W48 Interactive Kiosk
 - Building Identity**
W50 Primary, vehicular
W51 Freestanding, Ped
 - Parking Lot Id/Info**
W70 Primary ID
W71 Secondary ID
W72 Pole Mounted ID
 - W97 Street Signs

Note:
Lozenge orientation does not necessarily represent accurate sign placement.

▶ M
P ▼



- Legend**
- Off campus vehicular circulation
 - On campus primary veh. circulation
 - On campus secondary veh. circulation
 - Primary Pedestrian Circulation
 - Secondary Pedestrian Circulation
 - Parking Lot Permit Zones
 - ★ Information Kiosk
 - ▲ Existing Postings
 - Electronic Message Boards**
W10 Site ID, Freeway
W11 Campus ID
 - Campus Entry Monument**
W15 Primary ID
W16 Secondary ID
 - Pedestrian Information**
W36 Accessible Pathway
 - Pedestrian Information**
W40 Freestanding Directory, primary
W41 Wall Mounted Directory, secondary
W42 Freestanding Directory, secondary
W46 Info Kiosk, Posted Messages
W48 Interactive Kiosk
 - Building Identity**
W50 Primary, vehicular
W51 Freestanding, Ped
 - Parking Lot Id/Info**
W70 Primary ID
W71 Secondary ID
W72 Pole Mounted ID
 - W97 Street Signs

Note:
Lozenge orientation does not necessarily represent accurate sign placement.

J
M



- Legend**
- Off campus vehicular circulation
 - On campus primary veh. circulation
 - On campus secondary veh. circulation
 - Primary Pedestrian Circulation
 - Secondary Pedestrian Circulation
 - Parking Lot Permit Zones
 - Information Kiosk
 - Existing Postings
 - Electronic Message Boards**
W10 Site ID, Freeway
W11 Campus ID
 - Campus Entry Monument**
W15 Primary ID
W16 Secondary ID
 - Pedestrian Information**
W36 Accessible Pathway
 - Pedestrian Information**
W40 Freestanding Directory, primary
W41 Wall Mounted Directory
W42 Freestanding Directory, secondary
W46 Info Kiosk, Posted Messages
W48 Interactive Kiosk
 - Building Identity**
W50 Primary, vehicular
W51 Freestanding, Ped
 - Parking Lot Id/Info**
W70 Primary ID
W71 Secondary ID
W72 Pole Mounted ID
 - W97 Street Signs

Note:
Lozenge orientation does not necessarily represent accurate sign placement.

S

▲ K



T ▼

- Legend**
- Off campus vehicular circulation
 - On campus primary veh. circulation
 - On campus secondary veh. circulation
 - Primary Pedestrian Circulation
 - Secondary Pedestrian Circulation
 - Parking Lot Permit Zones
 - ★ Information Kiosk
 - ▲ Existing Postings
 - Electronic Message Boards**
W10 Site ID, Freeway
W11 Campus ID
 - Campus Entry Monument**
W15 Primary ID
W16 Secondary ID
 - Pedestrian Information**
W36 Accessible Pathway
 - Pedestrian Information**
W40 Freestanding Directory, primary
W41 Wall Mounted Directory
W42 Freestanding Directory, secondary
W46 Info Kiosk, Posted Messages
W48 Interactive Kiosk
 - Building Identity**
W50 Primary, vehicular
W51 Freestanding, Ped
 - Parking Lot Id/Info**
W70 Primary ID
W71 Secondary ID
W72 Pole Mounted ID
 - W97 Street Signs

Note:
Lozenge orientation does not necessarily represent accurate sign placement.

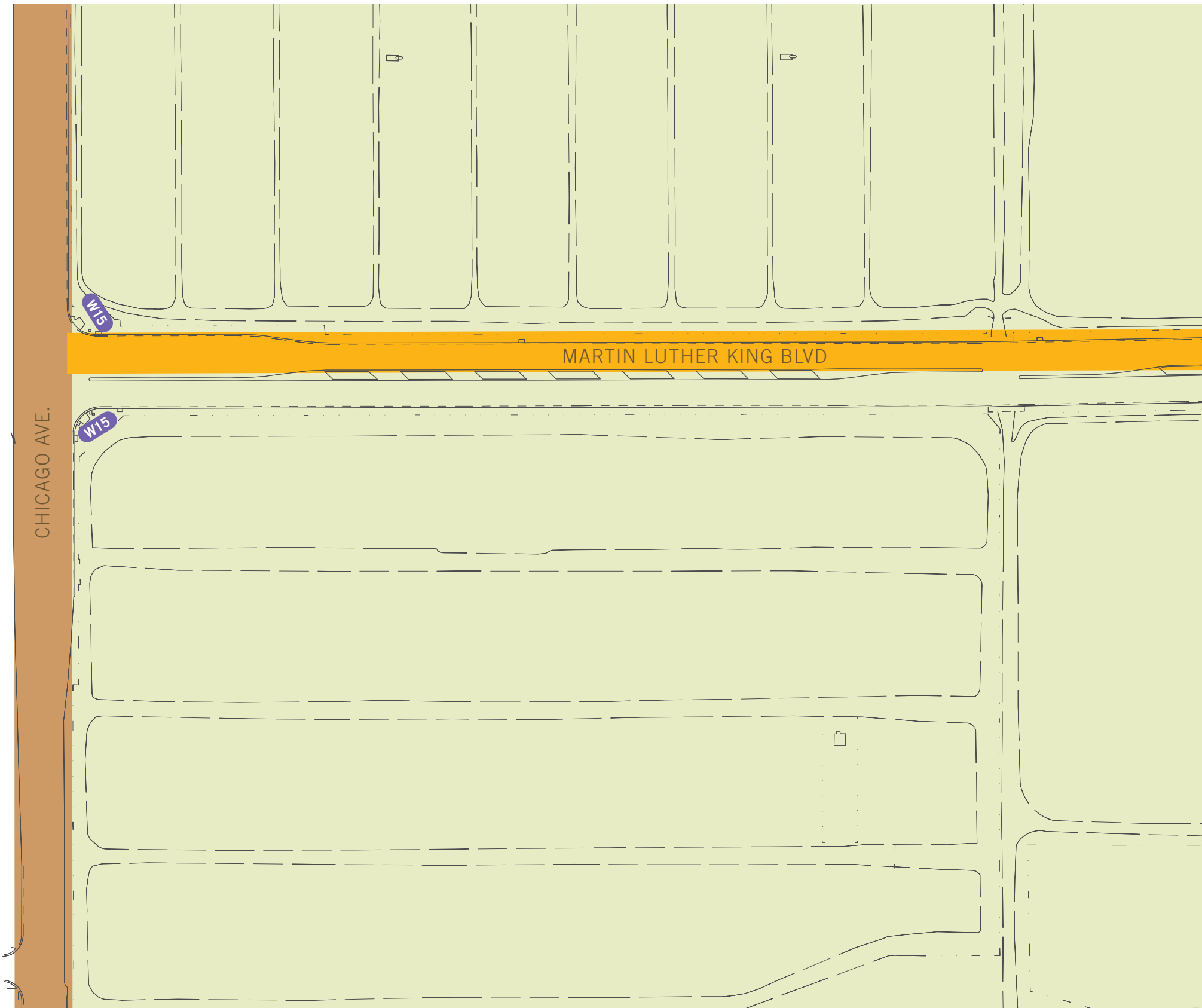

- Legend**
- Off campus vehicular circulation
 - On campus primary veh. circulation
 - On campus secondary veh. circulation
 - Primary Pedestrian Circulation
 - Secondary Pedestrian Circulation
 - Parking Lot Permit Zones
 - Information Kiosk
 - Existing Postings
 - Electronic Message Boards**
W10 Site ID, Freeway
W11 Campus ID
 - Campus Entry Monument**
W15 Primary ID
W16 Secondary ID
 - Pedestrian Information**
W36 Accessible Pathway
 - Pedestrian Information**
W40 Freestanding Directory, primary
W41 Wall Mounted Directory
W42 Freestanding Directory, secondary
W46 Info Kiosk, Posted Messages
W48 Interactive Kiosk
 - Building Identity**
W50 Primary, vehicular
W51 Freestanding, Ped
 - Parking Lot Id/Info**
W70 Primary ID
W71 Secondary ID
W72 Pole Mounted ID
 - W97 Street Signs

Note:
Lozenge orientation does not necessarily represent accurate sign placement.



Q ▲ M

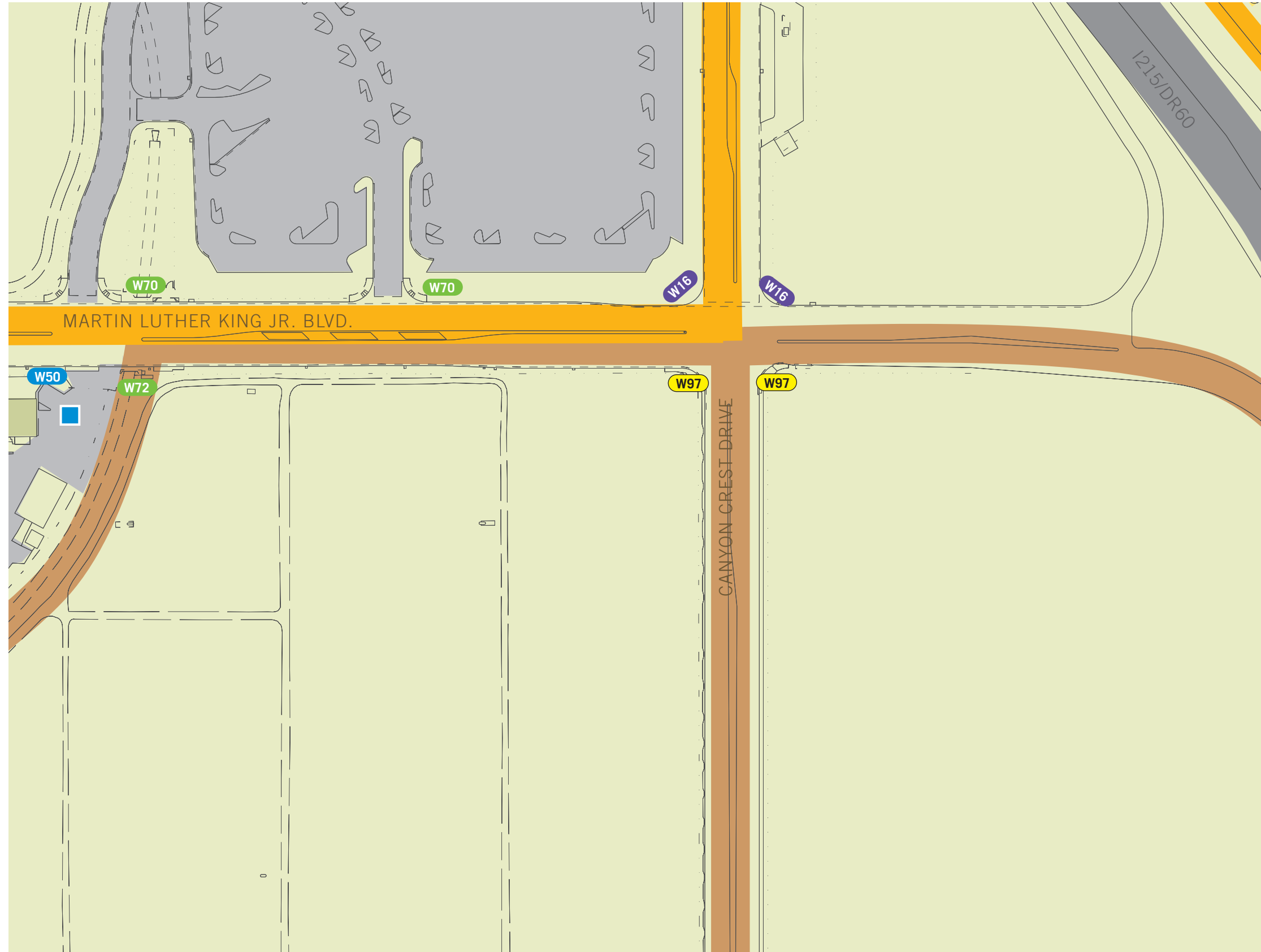

- Legend**
- Off campus vehicular circulation
 - On campus primary veh. circulation
 - On campus secondary veh. circulation
 - Primary Pedestrian Circulation
 - Secondary Pedestrian Circulation
 - Parking Lot Permit Zones
 - Information Kiosk
 - Existing Postings
 - Electronic Message Boards**
W10 Site ID, Freeway
W11 Campus ID
 - Campus Entry Monument**
W15 Primary ID
W16 Secondary ID
 - Pedestrian Information**
W36 Accessible Pathway
 - Pedestrian Information**
W40 Freestanding Directory, primary
W41 Wall Mounted Directory
W42 Freestanding Directory, secondary
W46 Info Kiosk, Posted Messages
W48 Interactive Kiosk
 - Building Identity**
W50 Primary, vehicular
W51 Freestanding, Ped
 - Parking Lot Id/Info**
W70 Primary ID
W71 Secondary ID
W72 Pole Mounted ID
 - W97 Street Signs

Note:
Lozenge orientation does not necessarily represent accurate sign placement.

▶ S

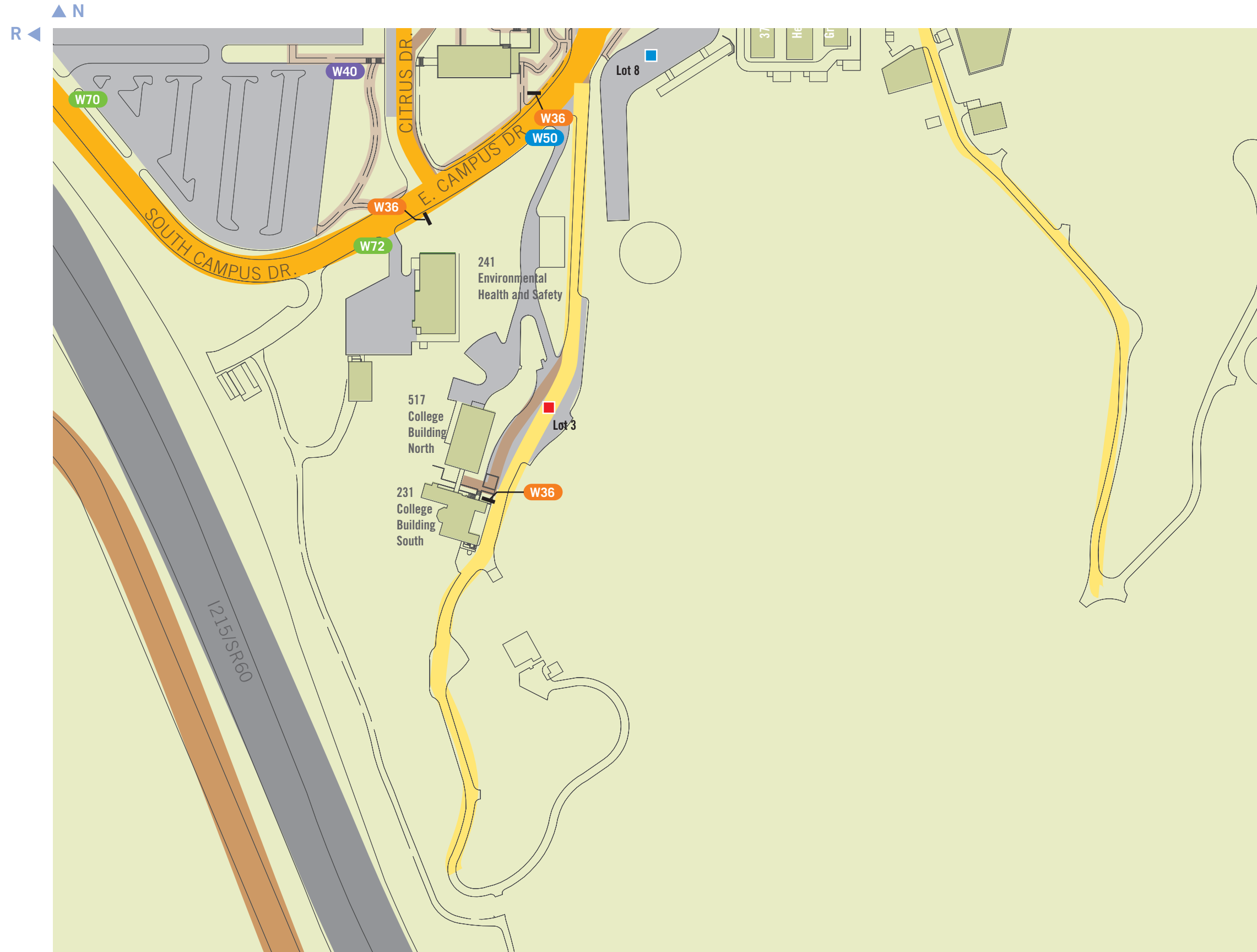

- Legend**
- Off campus vehicular circulation
 - On campus primary veh. circulation
 - On campus secondary veh. circulation
 - Primary Pedestrian Circulation
 - Secondary Pedestrian Circulation
 - Parking Lot Permit Zones
 - ★ Information Kiosk
 - ▲ Existing Postings
 - Electronic Message Boards**
W10 Site ID, Freeway
W11 Campus ID
 - Campus Entry Monument**
W15 Primary ID
W16 Secondary ID
 - Pedestrian Information**
W36 Accessible Pathway
 - Pedestrian Information**
W40 Freestanding Directory, primary
W41 Wall Mounted Directory
W42 Freestanding Directory, secondary
W46 Info Kiosk, Posted Messages
W48 Interactive Kiosk
 - Building Identity**
W50 Primary, vehicular
W51 Freestanding, Ped
 - Parking Lot Id/Info**
W70 Primary ID
W71 Secondary ID
W72 Pole Mounted ID
 - W97 Street Signs

Note:
Lozenge orientation does not necessarily represent accurate sign placement.

Location Plans and Messages

In order to provide clarity to the vehicular sign type locations, the following plans only show Vehicular Directional sign types.

Included are the following sign types:

W20

W21

W22

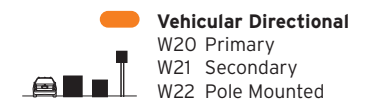

A ◀

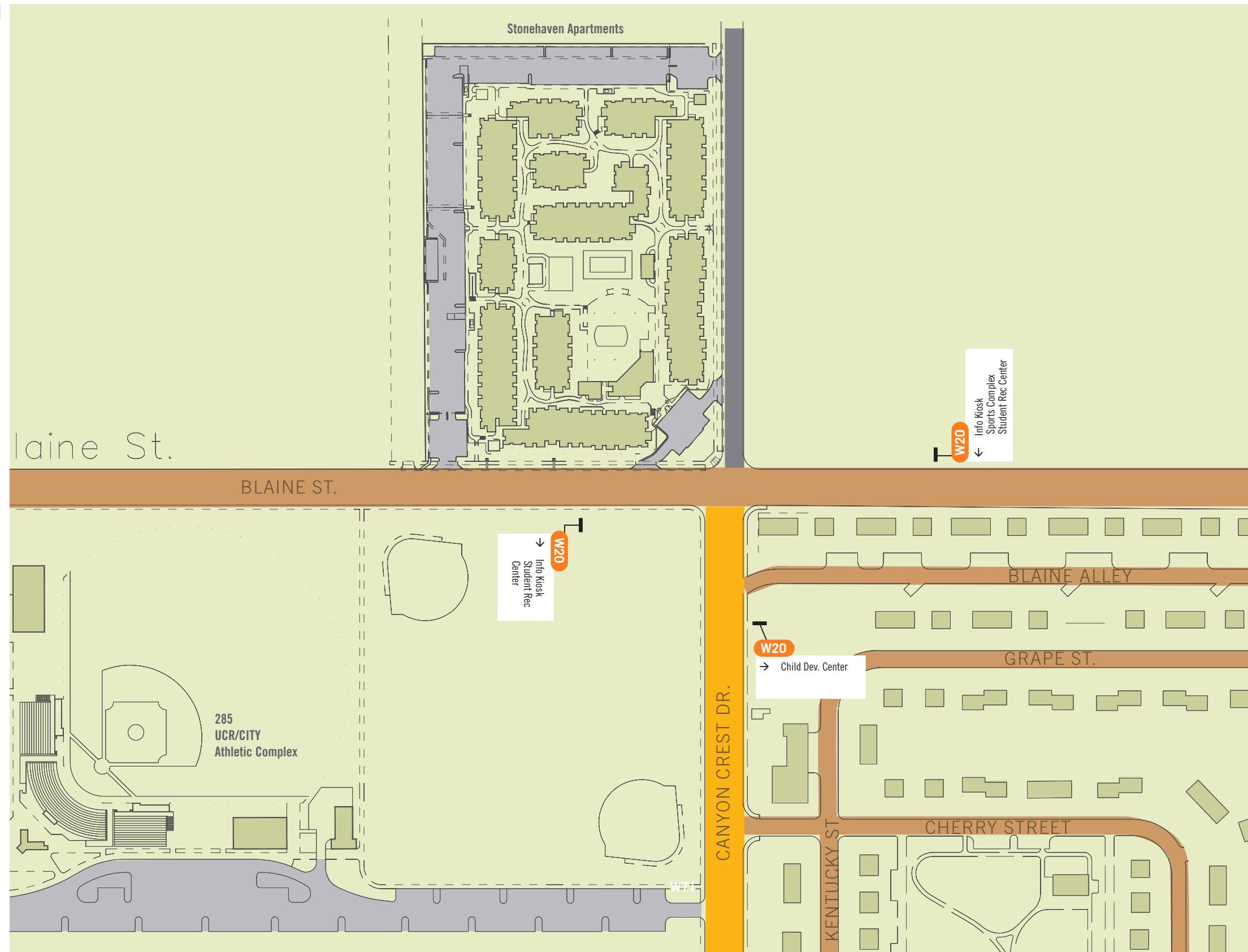

Vehicular Legend

- Off campus vehicular circulation
- On campus primary veh. circulation
- On campus secondary veh. circulation
- Parking Lot Permit Zones
- ★ Information Kiosk
- Vehicular Directional**
- W20 Primary
- W21 Secondary
- W22 Pole Mounted

Note:
Lozenge orientation does not necessarily represent accurate sign placement.

Vehicular Destinations

Direct from Perimeter of Campus

- Info Kiosk
- Botanical Gardens
- University Theater

Direct from 2-3 decision points away

- Child Dev. Center
- Corporation Yard
- East Campus
- Lothian Hall
- Parking Lot 10
- Parking Lot 13
- Parking Lot 24
- Parking Lot 30
- Parking Services
- Res. Halls
- Sports Complex
- Student Rec Center
- Health Services
- West Campus

Direct from 1 decision point away

- Ag. Operations
- Bannockburn
- Biomedical Teaching C omplex
- Riviera Library Parking
- USDA Lab

▶ C
E ▼

B ◀

Vehicular Legend

- Off campus vehicular circulation
- On campus primary veh. circulation
- On campus secondary veh. circulation
- Parking Lot Permit Zones
- ★ Information Kiosk

- Vehicular Directional**
- W20 Primary
- W21 Secondary
- W22 Pole Mounted

Note:
Lozenge orientation does not necessarily represent accurate sign placement.

Vehicular Destinations

Direct from Perimeter of Campus
Info Kiosk
Botanical Gardens
University Theater

Direct from 2-3 decision points away
Child Dev. Center
Corporation Yard
East Campus
Lothian Hall
Parking Lot 10
Parking Lot 13
Parking Lot 24
Parking Lot 30
Parking Services
Res. Halls
Sports Complex
Student Rec Center
Health Services
West Campus

Direct from 1 decision point away
Ag. Operations
Bannockburn
Biomedical Teaching C omplex
Riviera Library Parking
USDA Lab



Universi

F ▼

▲ B
D ◀



Vehicular Legend

- Off campus vehicular circulation
- On campus primary veh. circulation
- On campus secondary veh. circulation
- Parking Lot Permit Zones
- Information Kiosk
- Vehicular Directional
 - W20 Primary
 - W21 Secondary
 - W22 Pole Mounted

Note:
Lozenge orientation does not necessarily represent accurate sign placement.

Vehicular Destinations

Direct from Perimeter of Campus

- Info Kiosk
- Botanical Gardens
- University Theater

Direct from 2-3 decision points away

- Child Dev. Center
- Corporation Yard
- East Campus
- Lothian Hall
- Parking Lot 10
- Parking Lot 13
- Parking Lot 24
- Parking Lot 30
- Parking Services
- Res. Halls
- Sports Complex
- Student Rec Center
- Health Services
- West Campus

Direct from 1 decision point away

- Ag. Operations
- Bannockburn
- Biomedical Teaching C omplex
- Riviera Library Parking
- USDA Lab

▶ F
I ▼

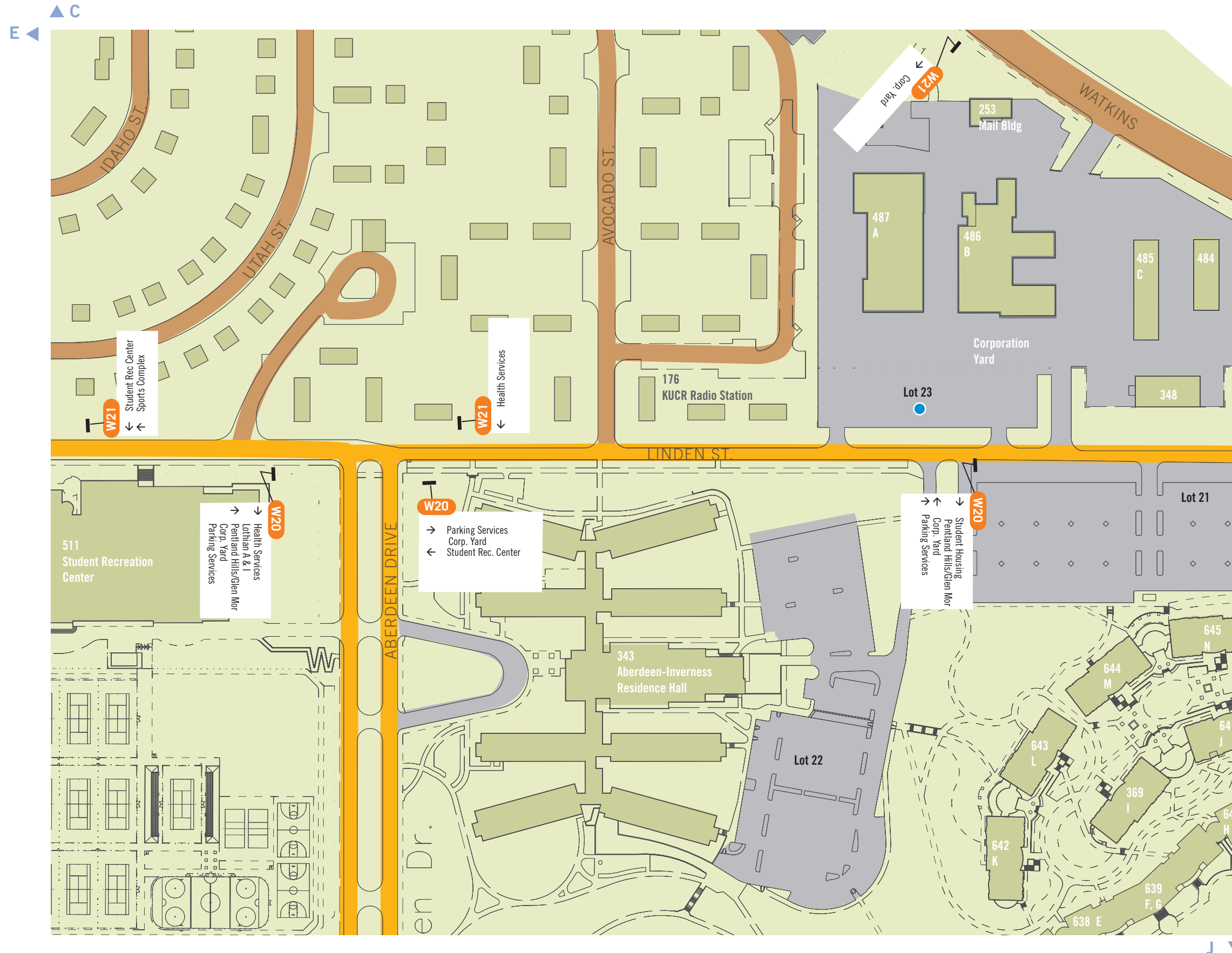

Vehicular Legend

- Off campus vehicular circulation
- On campus primary veh. circulation
- On campus secondary veh. circulation
- Parking Lot Permit Zones
- Information Kiosk
- Vehicular Directional**
- W20 Primary
- W21 Secondary
- W22 Pole Mounted

Note:
Lozenge orientation does not necessarily represent accurate sign placement.

Vehicular Destinations

Direct from Perimeter of Campus
Info Kiosk
Botanical Gardens
University Theater

Direct from 2-3 decision points away
Child Dev. Center
Corporation Yard
East Campus
Lothian Hall
Parking Lot 10
Parking Lot 13
Parking Lot 24
Parking Lot 30
Parking Services
Res. Halls
Sports Complex
Student Rec Center
Health Services
West Campus

Direct from 1 decision point away
Ag. Operations
Bannockburn
Biomedical Teaching C omplex
Riviera Library Parking
USDA Lab

F ◀

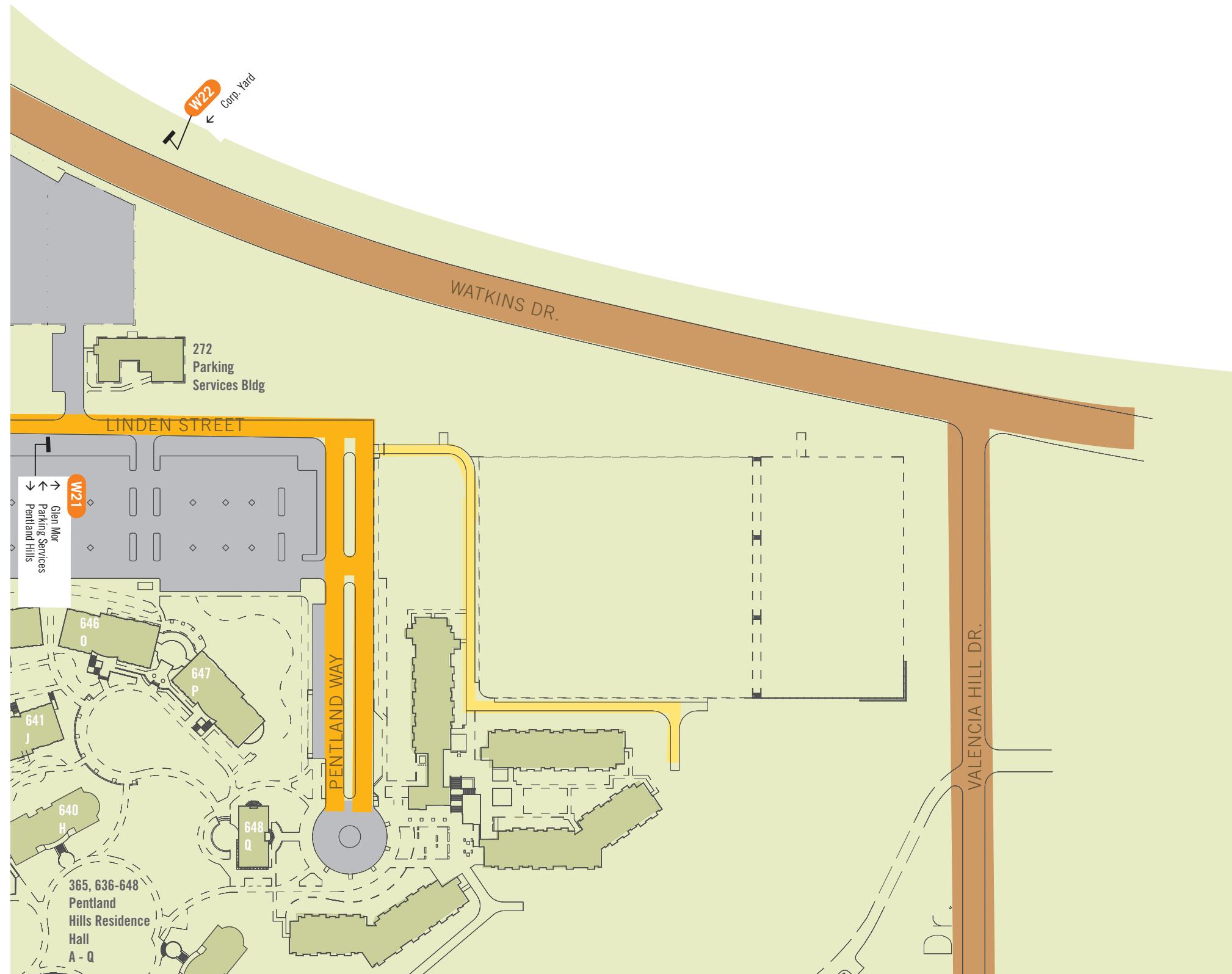

Vehicular Legend

- Off campus vehicular circulation
- On campus primary veh. circulation
- On campus secondary veh. circulation
- Parking Lot Permit Zones
- ★ Information Kiosk

- Vehicular Directional
- W20 Primary
- W21 Secondary
- W22 Pole Mounted

Note:
Lozenge orientation does not necessarily represent accurate sign placement.

Vehicular Destinations

Direct from Perimeter of Campus

- Info Kiosk
- Botanical Gardens
- University Theater

Direct from 2-3 decision points away

- Child Dev. Center
- Corporation Yard
- East Campus
- Lothian Hall
- Parking Lot 10
- Parking Lot 13
- Parking Lot 24
- Parking Lot 30
- Parking Services
- Res. Halls
- Sports Complex
- Student Rec Center
- Health Services
- West Campus

Direct from 1 decision point away

- Ag. Operations
- Bannockburn
- Biomedical Teaching C omplex
- Riviera Library Parking
- USDA Lab

K ▼

▲ D

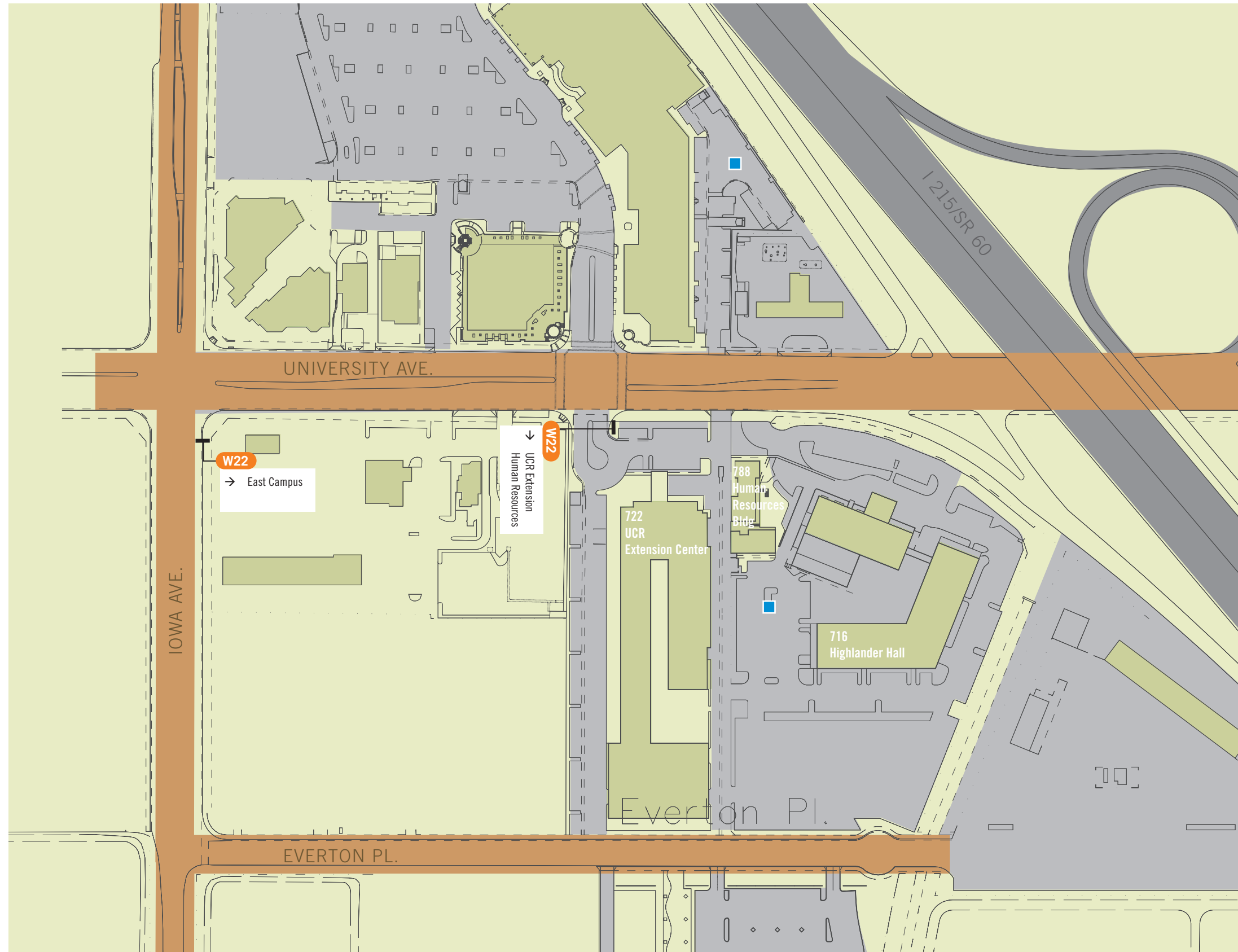

Vehicular Legend

- Off campus vehicular circulation
- On campus primary veh. circulation
- On campus secondary veh. circulation
- Parking Lot Permit Zones
- ★ Information Kiosk
- Vehicular Directional**
- W20 Primary
- W21 Secondary
- W22 Pole Mounted

Note:
Lozenge orientation does not necessarily represent accurate sign placement.

Vehicular Destinations

Direct from Perimeter of Campus
Info Kiosk
Botanical Gardens
University Theater

Direct from 2-3 decision points away
Child Dev. Center
Corporation Yard
East Campus
Lothian Hall
Parking Lot 10
Parking Lot 13
Parking Lot 24
Parking Lot 30
Parking Services
Res. Halls
Sports Complex
Student Rec Center
Health Services
West Campus

Direct from 1 decision point away
Ag. Operations
Bannockburn
Biomedical Teaching C omplex
Riviera Library Parking
USDA Lab

▶ I
L ▼

H ▲ E

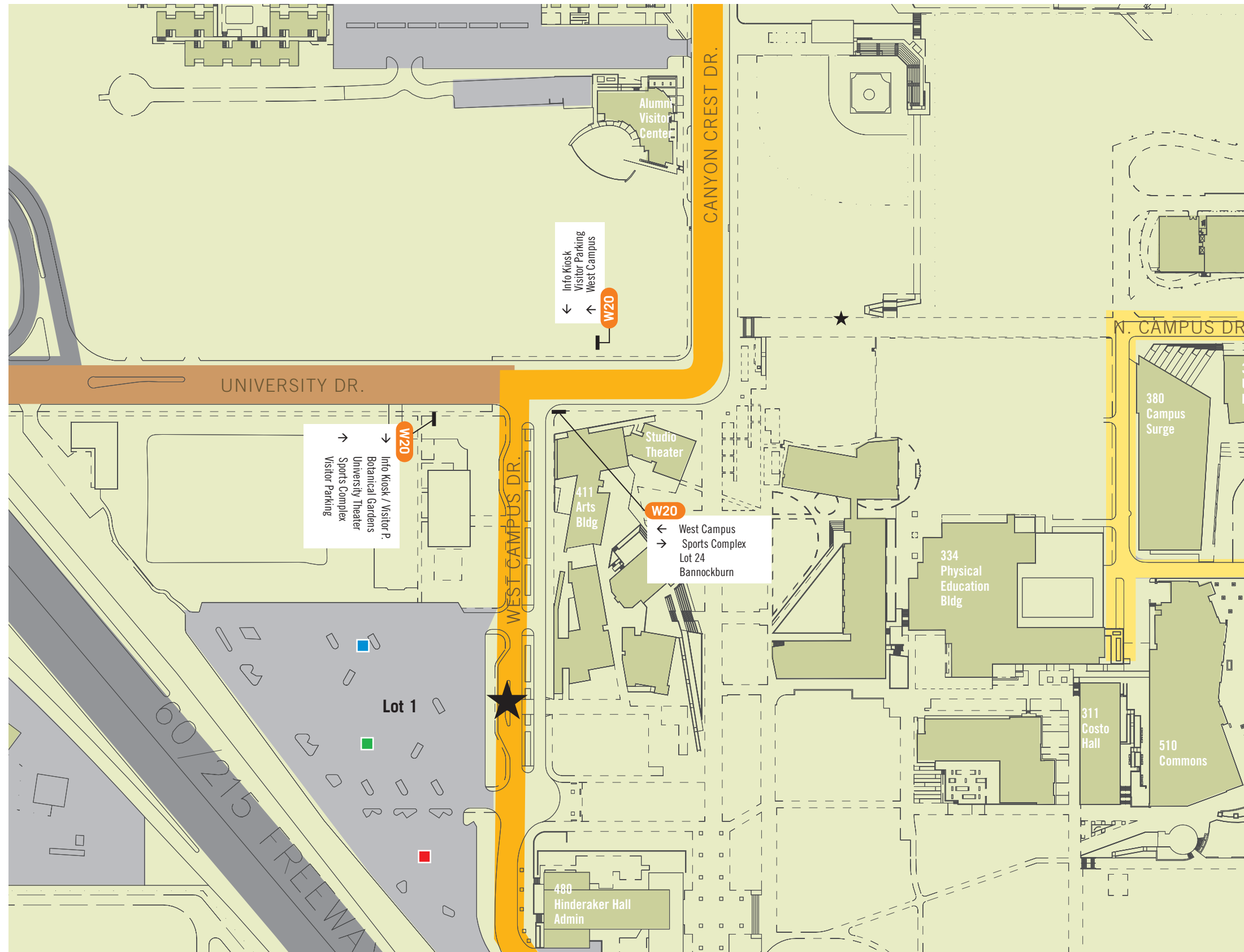

Vehicular Legend

- Off campus vehicular circulation
- On campus primary veh. circulation
- On campus secondary veh. circulation
- Parking Lot Permit Zones
- ★ Information Kiosk
- Vehicular Directional**
- W20 Primary
- W21 Secondary
- W22 Pole Mounted

Note:
Lozenge orientation does not necessarily represent accurate sign placement.

Vehicular Destinations

Direct from Perimeter of Campus

- Info Kiosk
- Botanical Gardens
- University Theater

Direct from 2-3 decision points away

- Child Dev. Center
- Corporation Yard
- East Campus
- Lothian Hall
- Parking Lot 10
- Parking Lot 13
- Parking Lot 24
- Parking Lot 30
- Parking Services
- Res. Halls
- Sports Complex
- Student Rec Center
- Health Services
- West Campus

Direct from 1 decision point away

- Ag. Operations
- Bannockburn
- Biomedical Teaching C omplex
- Riviera Library Parking
- USDA Lab

▲ J
M ▼

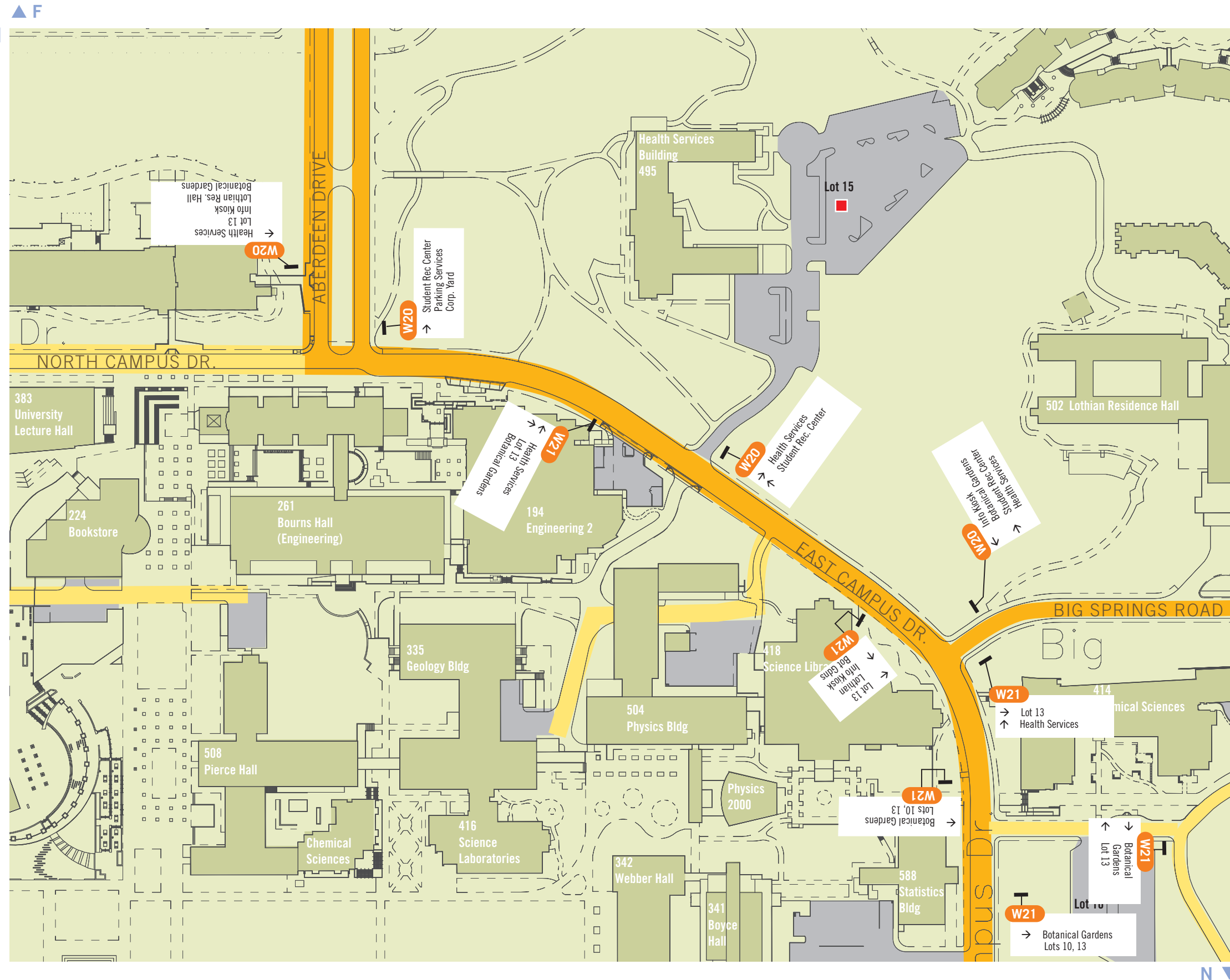

Vehicular Legend

- Off campus vehicular circulation
- On campus primary veh. circulation
- On campus secondary veh. circulation
- Parking Lot Permit Zones
- Information Kiosk
- Vehicular Directional**
- W20 Primary
- W21 Secondary
- W22 Pole Mounted

Note:
Lozenge orientation does not necessarily represent accurate sign placement.

Vehicular Destinations

Direct from Perimeter of Campus

- Info Kiosk
- Botanical Gardens
- University Theater

Direct from 2-3 decision points away

- Child Dev. Center
- Corporation Yard
- East Campus
- Lothian Hall
- Parking Lot 10
- Parking Lot 13
- Parking Lot 24
- Parking Lot 30
- Parking Services
- Res. Halls
- Sports Complex
- Student Rec Center
- Health Services
- West Campus

Direct from 1 decision point away

- Ag. Operations
- Bannockburn
- Biomedical Teaching C omplex
- Riviera Library Parking
- USDA Lab



Vehicular Legend

- Off campus vehicular circulation
 - On campus primary veh. circulation
 - On campus secondary veh. circulation
 - Parking Lot Permit Zones
 - Information Kiosk
-
- Vehicular Directional**
 - W20 Primary
 - W21 Secondary
 - W22 Pole Mounted

Note:
Lozenge orientation does not necessarily represent accurate sign placement.

Vehicular Destinations

- Direct from Perimeter of Campus**
- Info Kiosk
 - Botanical Gardens
 - University Theater

- Direct from 2-3 decision points away**
- Child Dev. Center
 - Corporation Yard
 - East Campus
 - Lothian Hall
 - Parking Lot 10
 - Parking Lot 13
 - Parking Lot 24
 - Parking Lot 30
 - Parking Services
 - Res. Halls
 - Sports Complex
 - Student Rec Center
 - Health Services
 - West Campus

- Direct from 1 decision point away**
- Ag. Operations
 - Bannockburn
 - Biomedical Teaching C omplex
 - Riviera Library Parking
 - USDA Lab

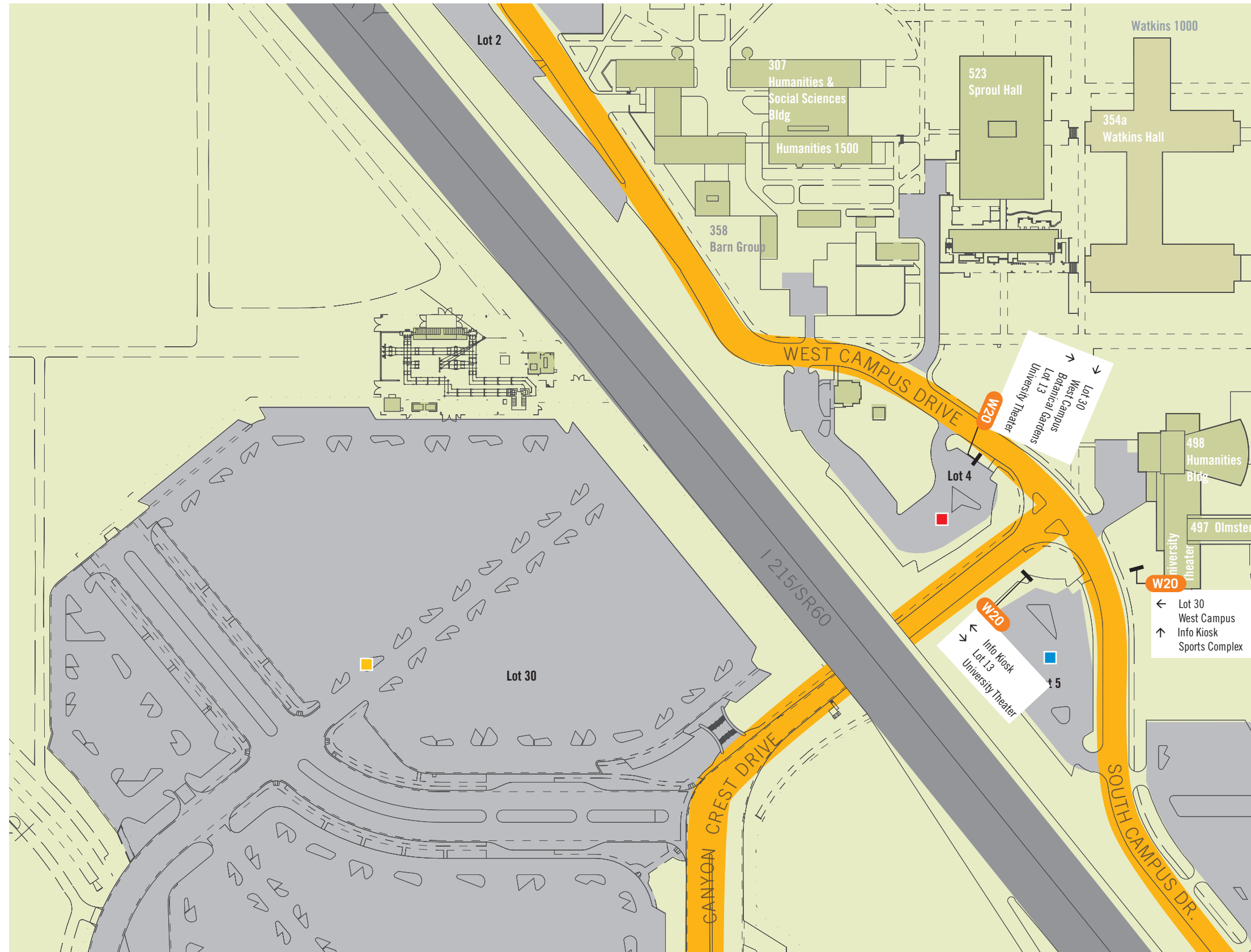

Vehicular Legend

- Off campus vehicular circulation
 - On campus primary veh. circulation
 - On campus secondary veh. circulation
 - Parking Lot Permit Zones
 - Information Kiosk
-
- Vehicular Directional**
 - W20 Primary
 - W21 Secondary
 - W22 Pole Mounted

Note:
Lozenge orientation does not necessarily represent accurate sign placement.

Vehicular Destinations

Direct from Perimeter of Campus

- Info Kiosk
- Botanical Gardens
- University Theater

Direct from 2-3 decision points away

- Child Dev. Center
- Corporation Yard
- East Campus
- Lothian Hall
- Parking Lot 10
- Parking Lot 13
- Parking Lot 24
- Parking Lot 30
- Parking Services
- Res. Halls
- Sports Complex
- Student Rec Center
- Health Services
- West Campus

Direct from 1 decision point away

- Ag. Operations
- Bannockburn
- Biomedical Teaching C omplex
- Riviera Library Parking
- USDA Lab



J
M



S
O

Vehicular Legend

- Off campus vehicular circulation
- On campus primary veh. circulation
- On campus secondary veh. circulation
- Parking Lot Permit Zones
- Information Kiosk
- Vehicular Directional**
 W20 Primary
 W21 Secondary
 W22 Pole Mounted

Note:
Lozenge orientation does not necessarily represent accurate sign placement.

Vehicular Destinations

Direct from Perimeter of Campus
 Info Kiosk
 Botanical Gardens
 University Theater

Direct from 2-3 decision points away
 Child Dev. Center
 Corporation Yard
 East Campus
 Lothian Hall
 Parking Lot 10
 Parking Lot 13
 Parking Lot 24
 Parking Lot 30
 Parking Services
 Res. Halls
 Sports Complex
 Student Rec Center
 Health Services
 West Campus

Direct from 1 decision point away
 Ag. Operations
 Bannockburn
 Biomedical Teaching C omplex
 Riviera Library Parking
 USDA Lab

P ▲ L



Vehicular Legend

- Off campus vehicular circulation
- On campus primary veh. circulation
- On campus secondary veh. circulation
- Parking Lot Permit Zones
- ★ Information Kiosk
- Vehicular Directional**
 W20 Primary
 W21 Secondary
 W22 Pole Mounted

Note:
Lozenge orientation does not necessarily represent accurate sign placement.

Vehicular Destinations

Direct from Perimeter of Campus
 Info Kiosk
 Botanical Gardens
 University Theater

Direct from 2-3 decision points away
 Child Dev. Center
 Corporation Yard
 East Campus
 Lothian Hall
 Parking Lot 10
 Parking Lot 13
 Parking Lot 24
 Parking Lot 30
 Parking Services
 Res. Halls
 Sports Complex
 Student Rec Center
 Health Services
 West Campus

Direct from 1 decision point away
 Ag. Operations
 Bannockburn
 Biomedical Teaching C omplex
 Riviera Library Parking
 USDA Lab

▶ R

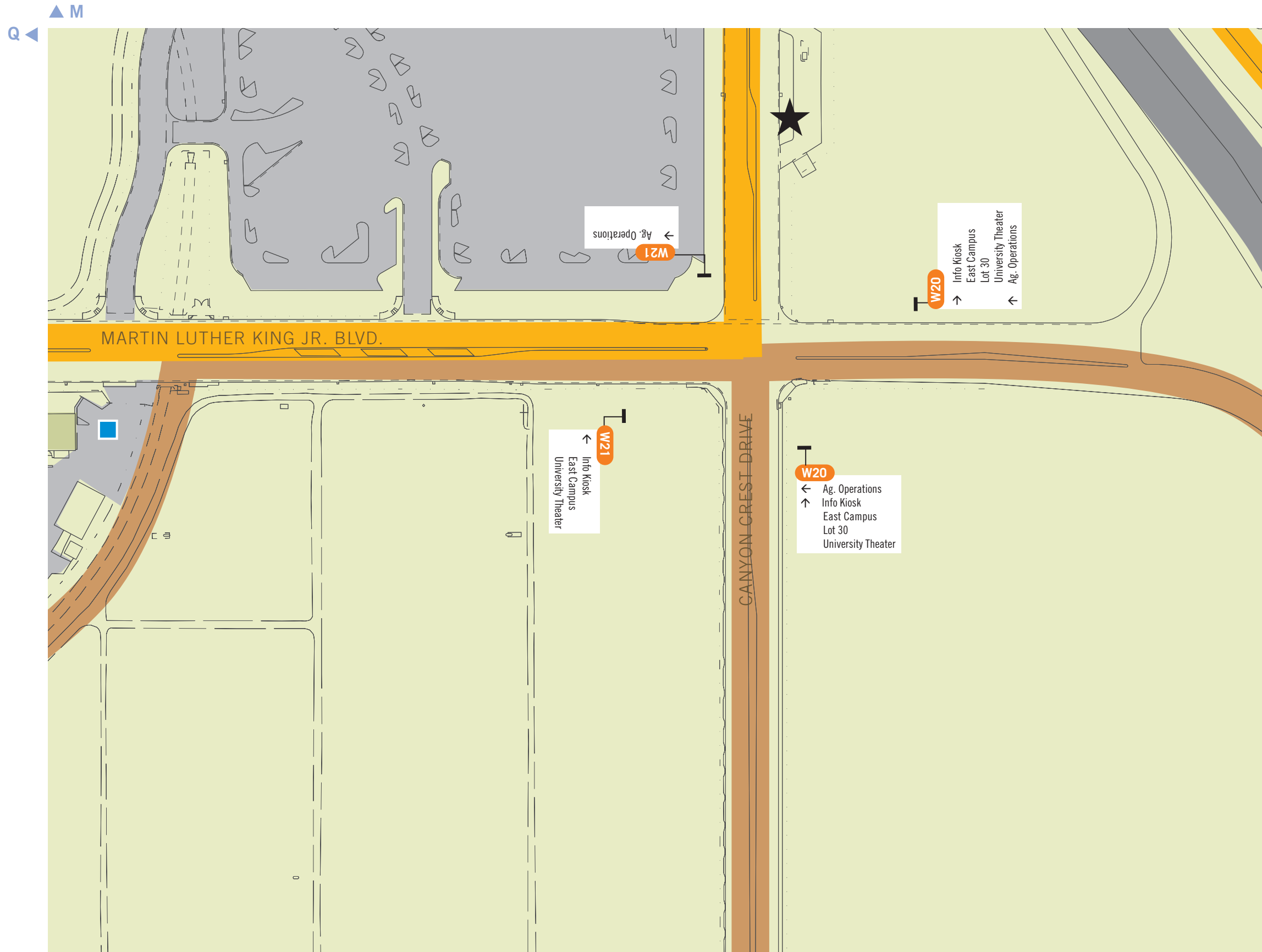

Vehicular Legend

- Off campus vehicular circulation
- On campus primary veh. circulation
- On campus secondary veh. circulation
- Parking Lot Permit Zones
- Information Kiosk
- Vehicular Directional**
- W20 Primary
- W21 Secondary
- W22 Pole Mounted

Note:
Lozenge orientation does not necessarily represent accurate sign placement.

Vehicular Destinations

Direct from Perimeter of Campus
Info Kiosk
Botanical Gardens
University Theater

Direct from 2-3 decision points away
Child Dev. Center
Corporation Yard
East Campus
Lothian Hall
Parking Lot 10
Parking Lot 13
Parking Lot 24
Parking Lot 30
Parking Services
Res. Halls
Sports Complex
Student Rec Center
Health Services
West Campus

Direct from 1 decision point away
Ag. Operations
Bannockburn
Biomedical Teaching Complex
Riviera Library Parking
USDA Lab

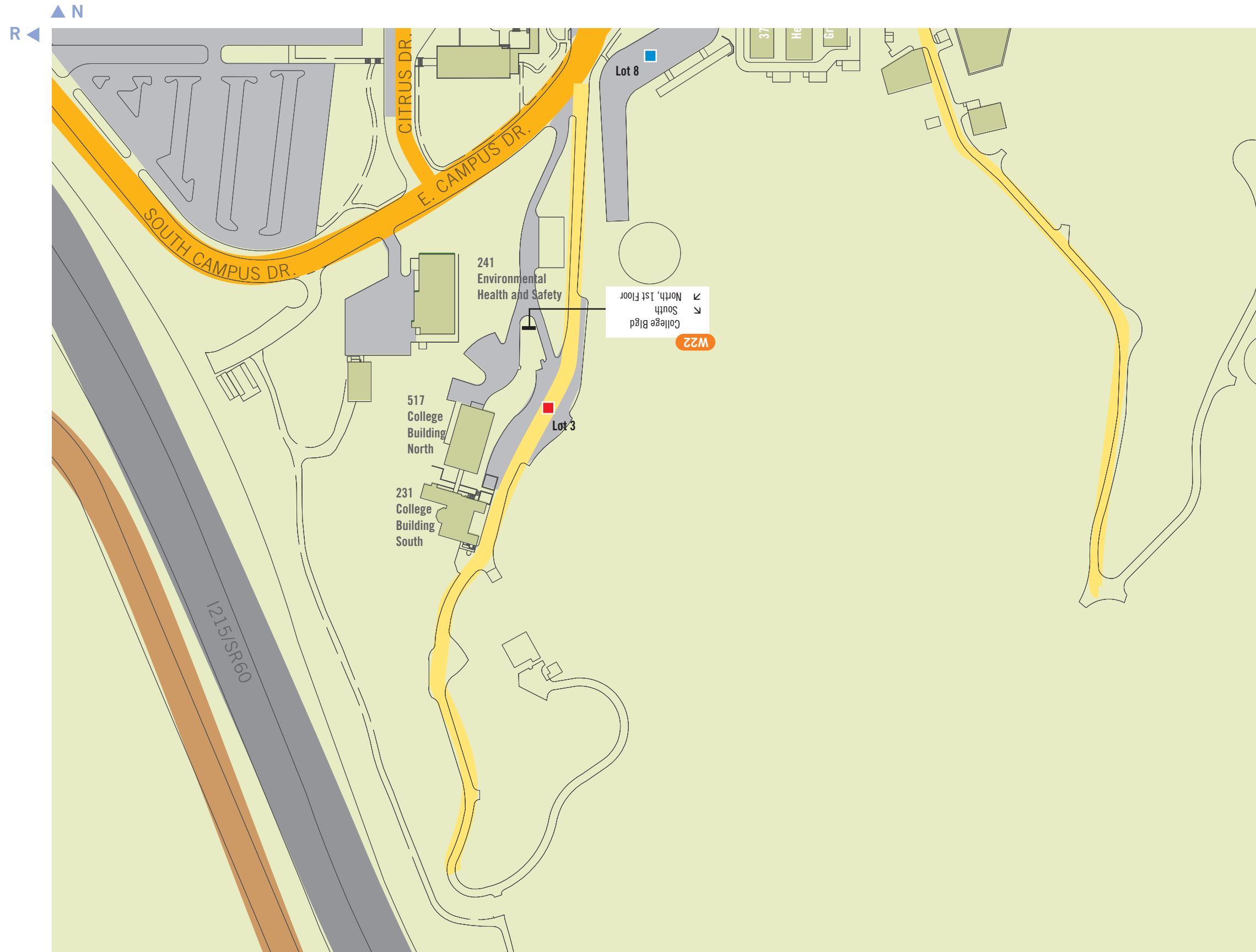

Vehicular Legend

- Off campus vehicular circulation
- On campus primary veh. circulation
- On campus secondary veh. circulation
- Parking Lot Permit Zones
- Information Kiosk

- Vehicular Directional**
- W20 Primary
- W21 Secondary
- W22 Pole Mounted

Note:
Lozenge orientation does not necessarily represent accurate sign placement.

Vehicular Destinations

Direct from Perimeter of Campus
Info Kiosk
Botanical Gardens
University Theater

Direct from 2-3 decision points away
Child Dev. Center
Corporation Yard
East Campus
Lothian Hall
Parking Lot 10
Parking Lot 13
Parking Lot 24
Parking Lot 30
Parking Services
Res. Halls
Sports Complex
Student Rec Center
Health Services
West Campus

Direct from 1 decision point away
Ag. Operations
Bannockburn
Biomedical Teaching Complex
Riviera Library Parking
USDA Lab

Location Plans and Messages

In order to provide clarity to the pedestrian sign type locations, the following plans only show Pedestrian Directional sign types.

Included are the following sign types:

W30

W35



▲ B
D ◀

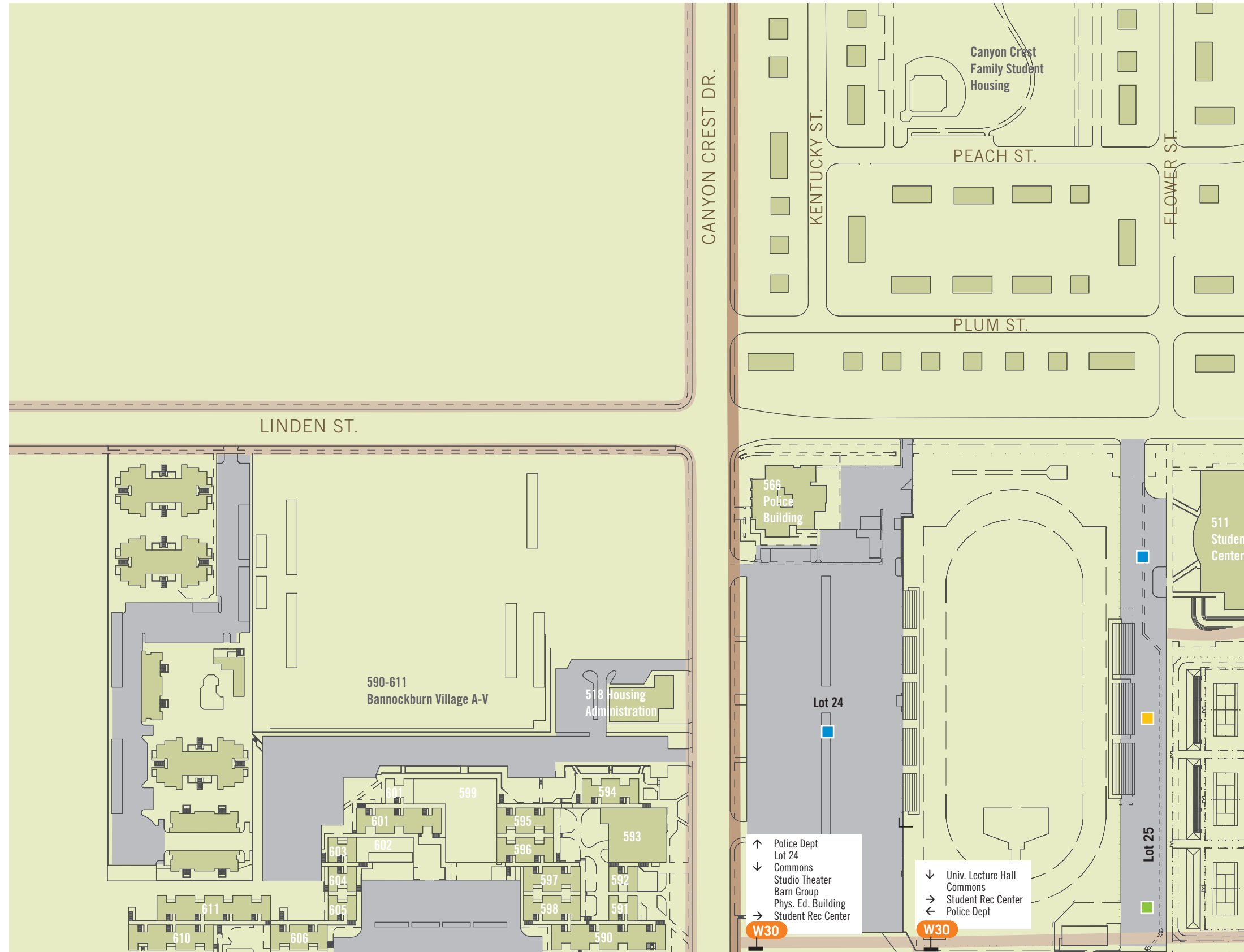

Pedestrian Legend

- Primary Pedestrian Circulation
- Secondary Pedestrian Circulation
- ★ Existing Directory (new directories to replace existing)
- ▲ Existing Postings
- ■ ■ ■ ■ Parking Lot Permit Zones

Pedestrian Directional

- W30 Blade Sign
- W35 Wall Mounted

Note:
Lozenge orientation does not necessarily represent accurate sign placement.

Pedestrian Destinations

Direct from Perimeter of Campus

- Commons
- Hinderacker Hall
- Humanities 1500
- Life Sciences 1500
- Physics 2000
- Univ. Lecture Hall
- Watkins 1000

Direct from Parking Lots

- Alumni Visitor Center
- Barn Group (Lots 1, 2, 24)
- P.E. Building (Lots 1, 24)
- Studio Theater (Lots 1, 2, 24)
- University Theater (Lot 30)

Direct from 2 - 3 decisions points away

- Bookstore
- College Bldg North and South
- Env. Health & Safety
- Extension/East Campus
- Lot 1, 2
- Lot 10, 13
- Lot 24
- Lot 30
- Police Dept.
- Student Recreation Center
- P.E. Building
- Health Services
- West Campus

- ↑ Police Dept
- ↑ Lot 24
- ↓ Commons
- ↓ Studio Theater
- ↓ Barn Group
- ↓ Phys. Ed. Building
- ↓ Student Rec Center

- ↓ Univ. Lecture Hall
- ↓ Commons
- Student Rec Center
- ← Police Dept

W30

W30

▶ F
I ▼

E C



Pedestrian Legend

- Primary Pedestrian Circulation
- Secondary Pedestrian Circulation
- ★ Existing Directory (new directories to replace existing)
- ▲ Existing Postings
- ■ ■ ■ ■ Parking Lot Permit Zones

- Pedestrian Directional**
- W30 Blade Sign
- W35 Wall Mounted

Note:
Lozenge orientation does not necessarily represent accurate sign placement.

Pedestrian Destinations

Direct from Perimeter of Campus

- Commons
- Hinderacker Hall
- Humanities 1500
- Life Sciences 1500
- Physics 2000
- Univ. Lecture Hall
- Watkins 1000

Direct from Parking Lots

- Alumni Visitor Center
- Barn Group (Lots 1, 2, 24)
- P.E. Building (Lots 1, 24)
- Studio Theater (Lots 1, 2, 24)
- University Theater (Lot 30)

Direct from 2 - 3 decisions points away

- Bookstore
- College Bldg North and South
- Env. Health & Safety
- Extension/East Campus
- Lot 1, 2
- Lot 10, 13
- Lot 24
- Lot 30
- Police Dept.
- Student Recreation Center
- P.E. Building
- Health Services
- West Campus

J G

▲ D



Pedestrian Legend

- Primary Pedestrian Circulation
- Secondary Pedestrian Circulation
- ★ Existing Directory (new directories to replace existing)
- ▲ Existing Postings
- ■ ■ ■ ■ Parking Lot Permit Zones

Pedestrian Directional

- W30 Blade Sign
- W35 Wall Mounted

Note:
Lozenge orientation does not necessarily represent accurate sign placement.

Pedestrian Destinations

Direct from Perimeter of Campus

- Commons
- Hinderaker Hall
- Humanities 1500
- Life Sciences 1500
- Physics 2000
- Univ. Lecture Hall
- Watkins 1000

Direct from Parking Lots

- Alumni Visitor Center
- Barn Group (Lots 1, 2, 24)
- P.E. Building (Lots 1, 24)
- Studio Theater (Lots 1, 2, 24)
- University Theater (Lot 30)

Direct from 2 - 3 decisions points away

- Bookstore
- College Bldg North and South
- Env. Health & Safety
- Extension/East Campus
- Lot 1, 2
- Lot 10, 13
- Lot 24
- Lot 30
- Police Dept.
- Student Recreation Center
- P.E. Building
- Health Services
- West Campus

▶ I
L ▼

H ▲ E



Pedestrian Legend

- Primary Pedestrian Circulation
- Secondary Pedestrian Circulation
- ★ Existing Directory (new directories to replace existing)
- ▲ Existing Postings
- ■ ■ ■ ■ Parking Lot Permit Zones

Pedestrian Directional

- W30 Blade Sign
- W35 Wall Mounted

Note:
Lozenge orientation does not necessarily represent accurate sign placement.

Pedestrian Destinations

Direct from Perimeter of Campus

- Commons
- Hinderaker Hall
- Humanities 1500
- Life Sciences 1500
- Physics 2000
- Univ. Lecture Hall
- Watkins 1000

Direct from Parking Lots

- Alumni Visitor Center
- Barn Group (Lots 1, 2, 24)
- P.E. Building (Lots 1, 24)
- Studio Theater (Lots 1, 2, 24)
- University Theater (Lot 30)

Direct from 2 - 3 decisions points away

- Bookstore
- College Bldg North and South
- Env. Health & Safety
- Extension/East Campus
- Lot 1, 2
- Lot 10, 13
- Lot 24
- Lot 30
- Police Dept.
- Student Recreation Center
- P.E. Building
- Health Services
- West Campus

▲ J
M ▼

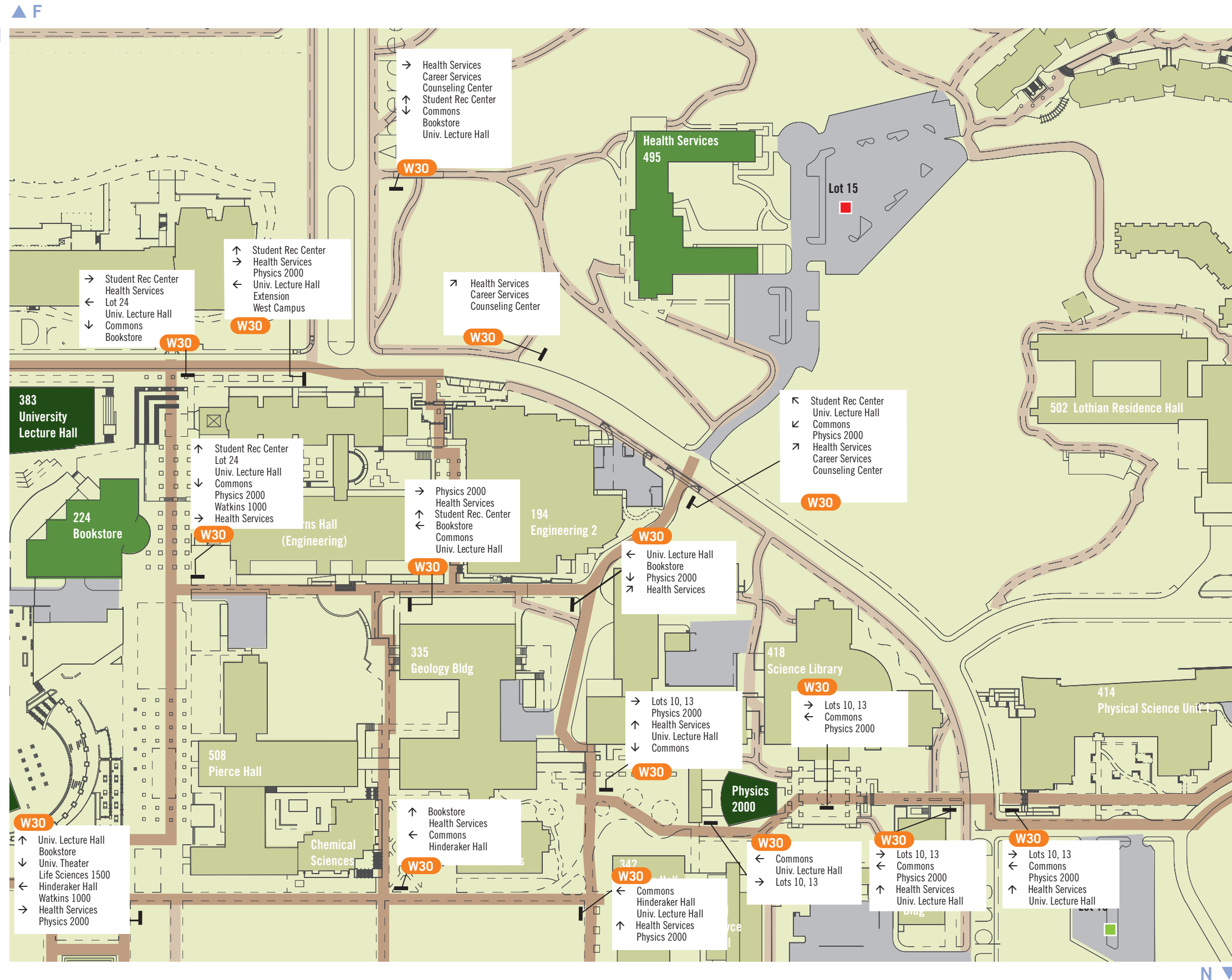

- Pedestrian Legend**
- Primary Pedestrian Circulation
 - Secondary Pedestrian Circulation
 - ★ Existing Directory (new directories to replace existing)
 - ▲ Existing Postings
 - ■ ■ ■ ■ Parking Lot Permit Zones

- Pedestrian Directional**
- W30 Blade Sign
 - W35 Wall Mounted

Note:
Lozenge orientation does not necessarily represent accurate sign placement.

Pedestrian Destinations

Direct from Perimeter of Campus

- Commons
- Hinderaker Hall
- Humanities 1500
- Life Sciences 1500
- Physics 2000
- Univ. Lecture Hall
- Watkins 1000

Direct from Parking Lots

- Alumni Visitor Center
- Barn Group (Lots 1, 2, 24)
- P.E. Building (Lots 1, 24)
- Studio Theater (Lots 1, 2, 24)
- University Theater (Lot 30)

Direct from 2 - 3 decisions points away

- Bookstore
- College Bldg North and South
- Env. Health & Safety
- Extension/East Campus
- Lot 1, 2
- Lot 10, 13
- Lot 24
- Lot 30
- Police Dept.
- Student Recreation Center
- P.E. Building
- Health Services
- West Campus

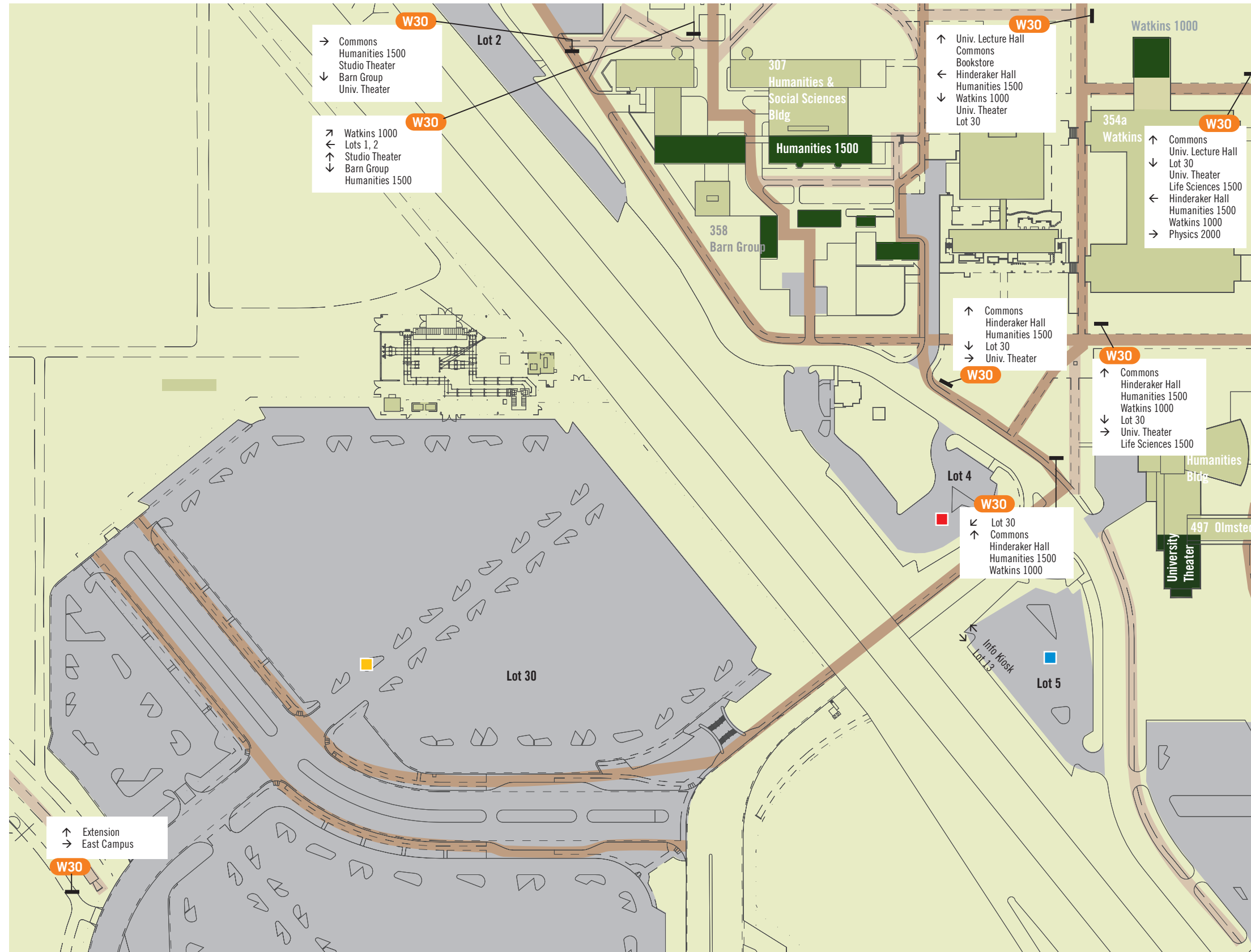

Pedestrian Legend

- Primary Pedestrian Circulation
- Secondary Pedestrian Circulation
- Existing Directory (new directories to replace existing)
- Existing Postings
- Parking Lot Permit Zones
- Pedestrian Directional**
 - W30 Blade Sign
 - W35 Wall Mounted

Note: Lozenge orientation does not necessarily represent accurate sign placement.

Pedestrian Destinations

Direct from Perimeter of Campus

- Commons
- Hinderaker Hall
- Humanities 1500
- Life Sciences 1500
- Physics 2000
- Univ. Lecture Hall
- Watkins 1000

Direct from Parking Lots

- Alumni Visitor Center
- Barn Group (Lots 1, 2, 24)
- P.E. Building (Lots 1, 24)
- Studio Theater (Lots 1, 2, 24)
- University Theater (Lot 30)

Direct from 2 - 3 decisions points away

- Bookstore
- College Bldg North and South
- Env. Health & Safety
- Extension/East Campus
- Lot 1, 2
- Lot 10, 13
- Lot 24
- Lot 30
- Police Dept.
- Student Recreation Center
- P.E. Building
- Health Services
- West Campus

J
M

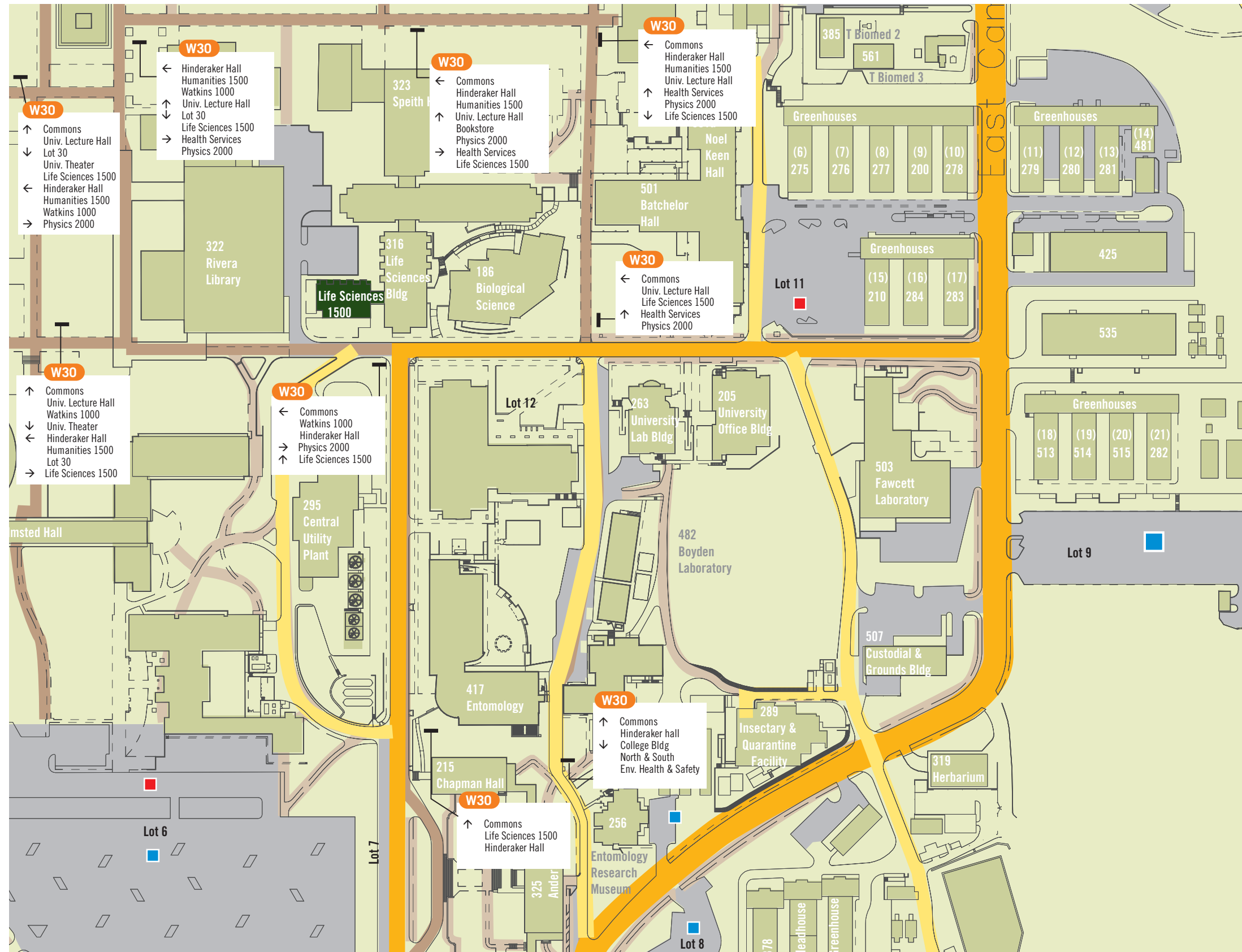

Pedestrian Legend

- Primary Pedestrian Circulation
- Secondary Pedestrian Circulation
- Existing Directory (new directories to replace existing)
- Existing Postings
- Parking Lot Permit Zones

Pedestrian Directional

- W30 Blade Sign
- W35 Wall Mounted

Note:
Lozenge orientation does not necessarily represent accurate sign placement.

Pedestrian Destinations

Direct from Perimeter of Campus

- Commons
- Hinderaker Hall
- Humanities 1500
- Life Sciences 1500
- Physics 2000
- Univ. Lecture Hall
- Watkins 1000

Direct from Parking Lots

- Alumni Visitor Center
- Barn Group (Lots 1, 2, 24)
- P.E. Building (Lots 1, 24)
- Studio Theater (Lots 1, 2, 24)
- University Theater (Lot 30)

Direct from 2 - 3 decisions points away

- Bookstore
- College Bldg North and South
- Env. Health & Safety
- Extension/East Campus
- Lot 1, 2
- Lot 10, 13
- Lot 24
- Lot 30
- Police Dept.
- Student Recreation Center
- P.E. Building
- Health Services
- West Campus

S O



Pedestrian Legend

- Primary Pedestrian Circulation
- Secondary Pedestrian Circulation
- Existing Directory (new directories to replace existing)
- Existing Postings
- Parking Lot Permit Zones

Pedestrian Directional

- W30 Blade Sign
- W35 Wall Mounted

Note:
Lozenge orientation does not necessarily represent accurate sign placement.

Pedestrian Destinations

- Direct from Perimeter of Campus**
- Commons
 - Hinderacker Hall
 - Humanities 1500
 - Life Sciences 1500
 - Physics 2000
 - Univ. Lecture Hall
 - Watkins 1000

- Direct from Parking Lots**
- Alumni Visitor Center
 - Barn Group (Lots 1, 2, 24)
 - P.E. Building (Lots 1, 24)
 - Studio Theater (Lots 1, 2, 24)
 - University Theater (Lot 30)

- Direct from 2 - 3 decisions points away**
- Bookstore
 - College Bldg North and South
 - Env. Health & Safety
 - Extension/East Campus
 - Lot 1, 2
 - Lot 10, 13
 - Lot 24
 - Lot 30
 - Police Dept.
 - Student Recreation Center
 - P.E. Building
 - Health Services
 - West Campus

Aberdeen Inverness (343)		qty
W50	Vehicular Bldg ID	1
W51	Freestanding, Ped	0
W52	Wall Mounted	0
W53	Vinyl Letters on Door	0
W54	Parapet Letters	0
B95	Loading Dock ID	0



Keep existing sign



Replace with W50 Vehicular Bldg ID

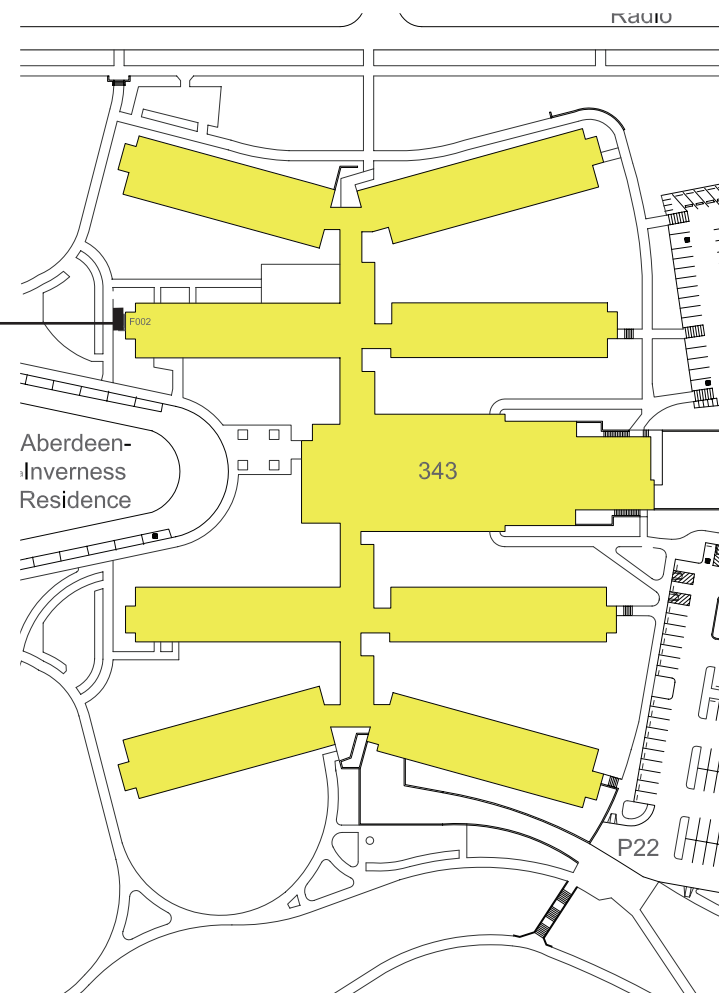

Agricultural Operations		qty
W50	Vehicular Bldg ID	1
W51	Freestanding, Ped	0
W52	Wall Mounted	0
W53	Vinyl Letters on Door	0
W54	Parapet Letters	0
B95	Loading Dock ID	0

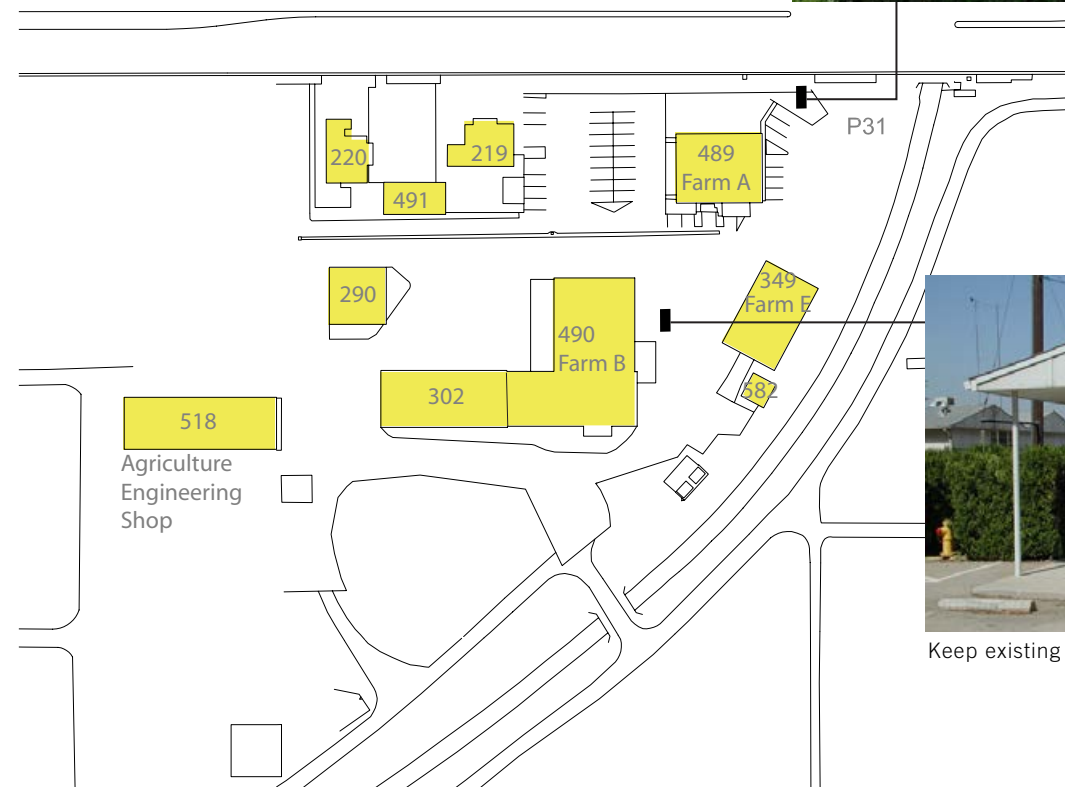

Replace with W50 Vehicular Bldg ID



Keep existing sign

Anderson Hall I & II (325 & 357)		qty
W50	Vehicular Bldg ID	0
W51	Freestanding, Ped	1
W52	Wall Mounted	0
W53	Vinyl Letters on Door	4
W54	Parapet Letters	0
B95	Loading Dock ID	0

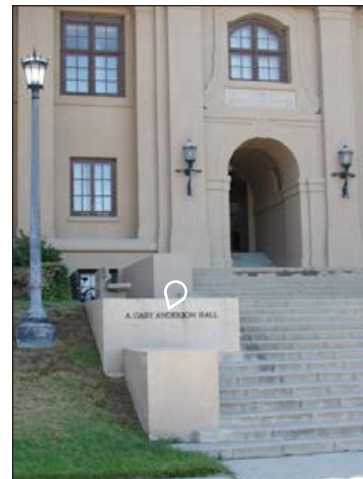

Keep existing sign



Add W51 Freestanding Bldg ID



Add W53 Vinyl Letters on Door



Keep existing sign

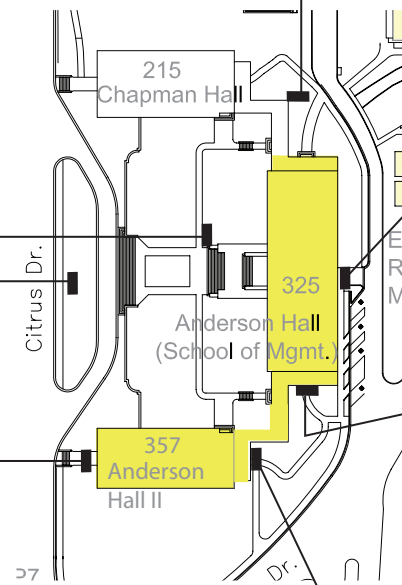

Add W53 Vinyl Letters on Door



Add W53 Vinyl Letters on Door



Add W53 Vinyl Letters on Door

Arts (411)		qty
W50	Vehicular Bldg ID	0
W51	Freestanding, Ped	1
W52	Wall Mounted	0
W53	Vinyl Letters on Door	0
W54	Parapet Letters	2
B95	Loading Dock ID	1

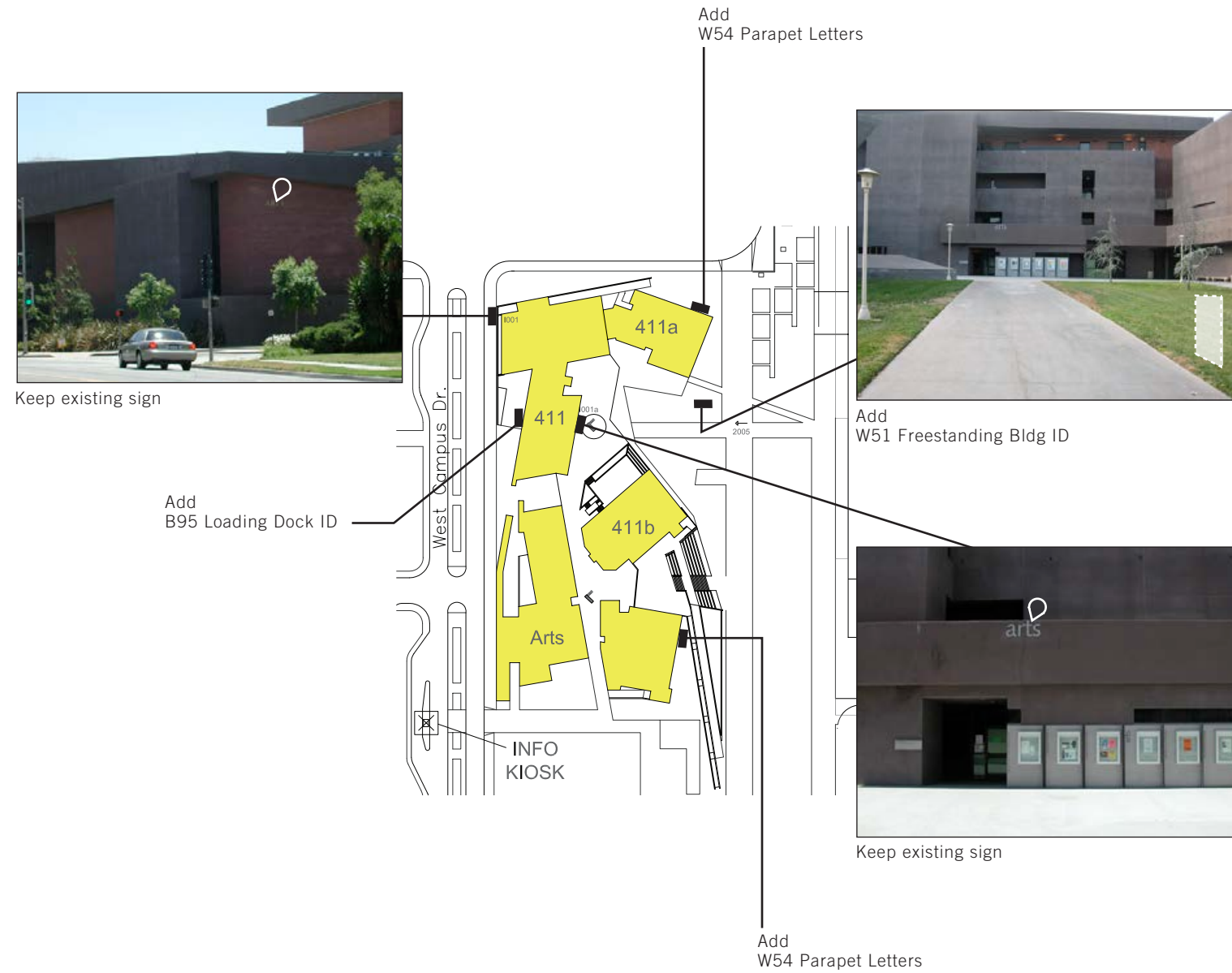

The Barn, Theater Workshop & Barn Stable (358, 251, & 271)

	qty
W50 Vehicular Bldg ID	1
W51 Freestanding, Ped	1
W52 Wall Mounted	6
W53 Vinyl Letters on Door	0
W54 Parapet Letters	0
B95 Loading Dock ID	0



Add W52 Wall Mounted Bldg ID



Replace with W52 Wall Mounted Bldg ID



Add W51 Freestanding Bldg ID



Add W52 Wall Mounted Bldg ID



Add W52 Wall Mounted Bldg ID



Replace with W50 Vehicular Bldg ID



Add W52 Wall Mounted Bldg ID

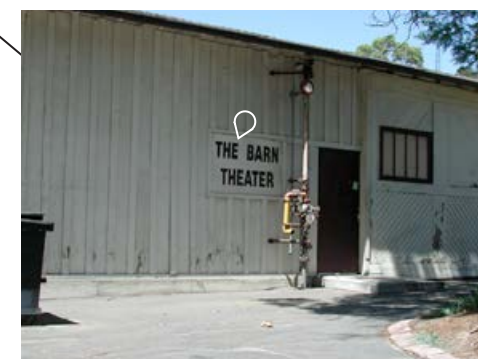

Replace with W52 Wall Mounted Bldg ID

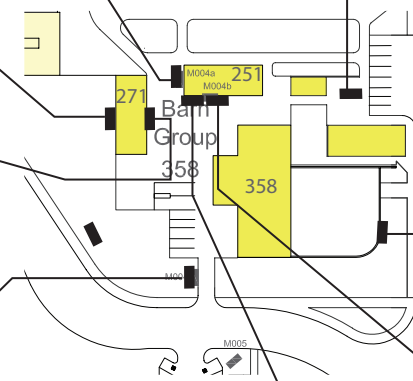

Bannockburn Village Buildings A-V (590-611)		qty
W50	Vehicular Bldg ID	0
W51	Freestanding, Ped	1
W52	Wall Mounted	0
W53	Vinyl Letters on Door	0
W54	Parapet Letters	0
B95	Loading Dock ID	0

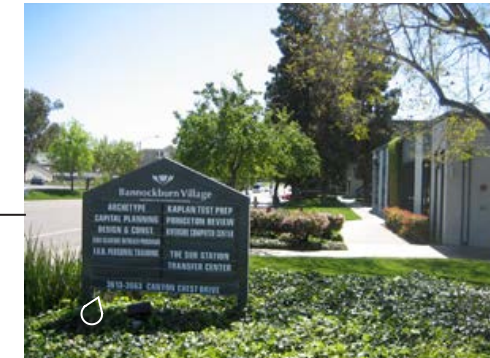
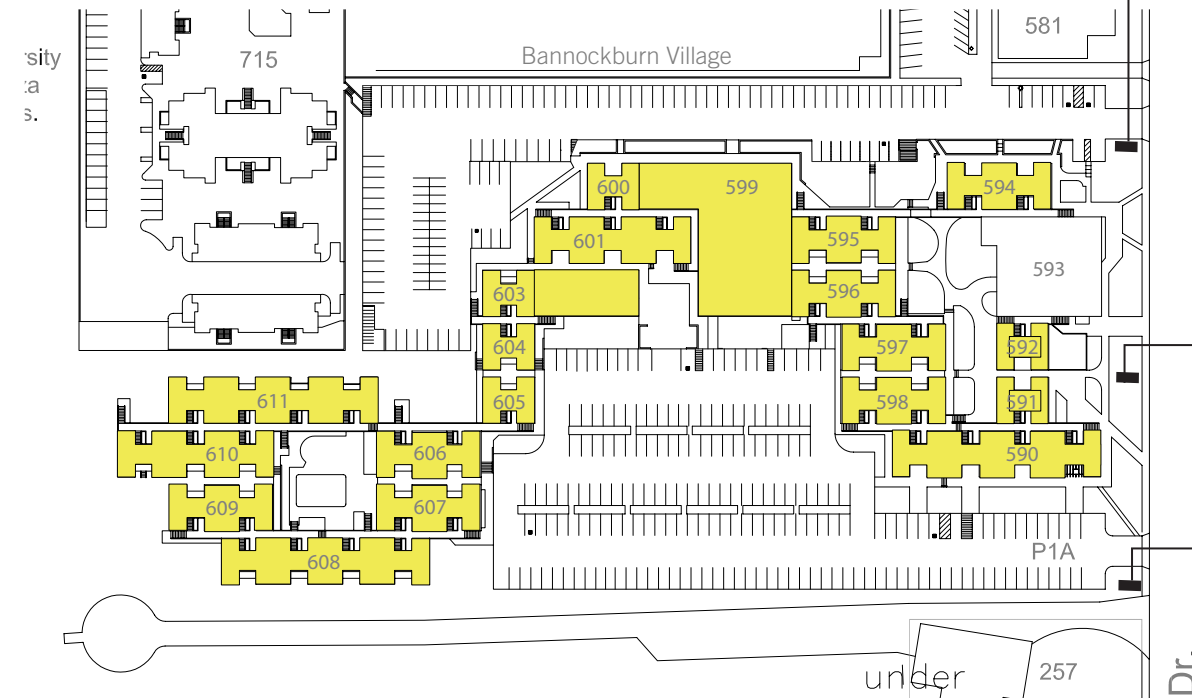

Remove Sign
 Note: A Parking Sign (W70) with bldg name has been included in the sign location plan

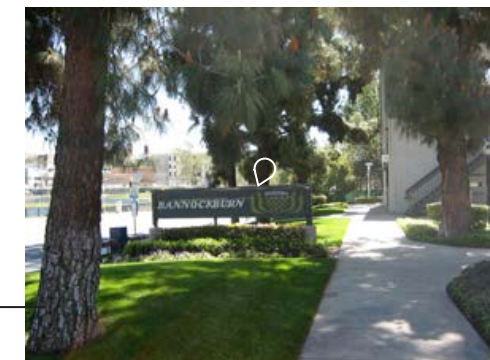

Replace with
 W51 Bldg ID

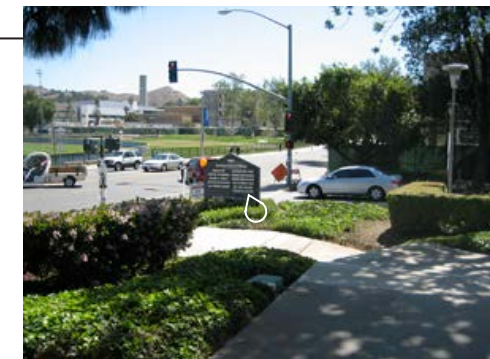

Remove Sign
 Note: A Parking Sign (W70) with bldg name has been included in the sign location plan

Batchelor Hall (501)		qty
W50	Vehicular Bldg ID	1
W51	Freestanding, Ped	2
W52	Wall Mounted	2
W53	Vinyl Letters on Door	5
W54	Parapet Letters	0
B95	Loading Dock ID	1



Replace existing sign with W52 Wall Mounted
Add W53 Vinyl Letters on Door



Add W51 Freestanding Building ID

Add W53 Vinyl Letters on Door



Keep existing sign
Add W53 Vinyl Letters on Door

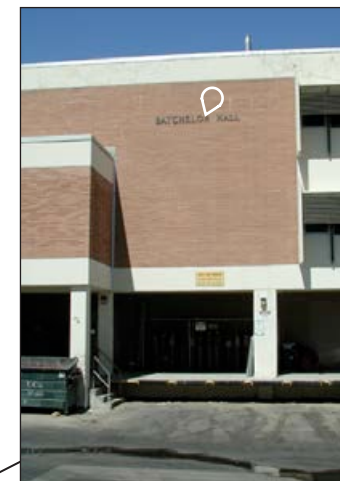

Keep existing sign
Add B95 Loading Dock



Keep existing sign

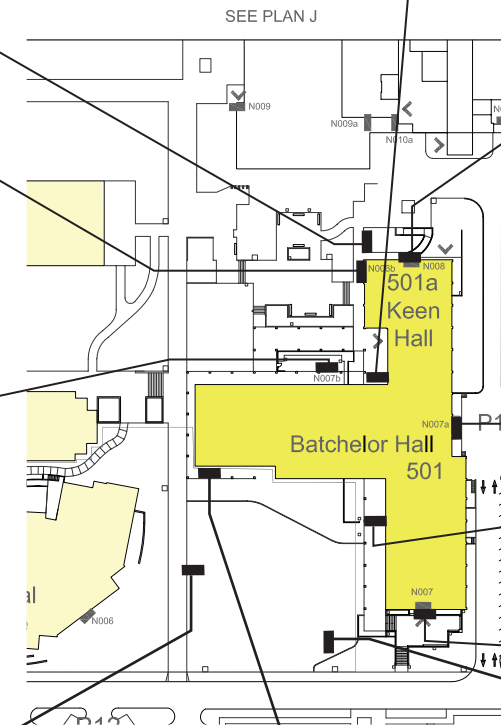

Add W53 Vinyl Letters on Door

Add W51 Freestanding Building ID



Add W52 Wall Mounted Bldg ID
W53 Vinyl Letters on Door



Add W50 Vehicular Building ID



Keep existing sign

Biological Sciences (186)		qty
W50	Vehicular Bldg ID	0
W51	Freestanding, Ped	1
W52	Wall Mounted	1
W53	Vinyl Letters on Door	3
W54	Parapet Letters	0
B95	Loading Dock ID	0



Add W53 Vinyl Letters on Door



Add W53 Vinyl Letters on Door



Add W52 Wall Mounted Building ID



Add W53 Vinyl Letters on Door

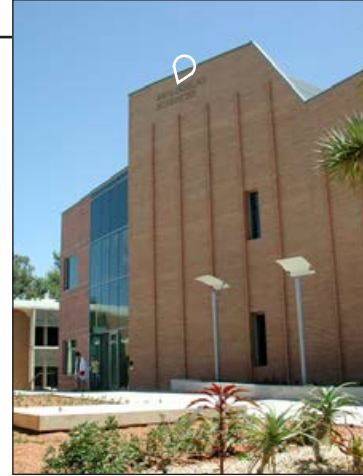

Keep existing sign

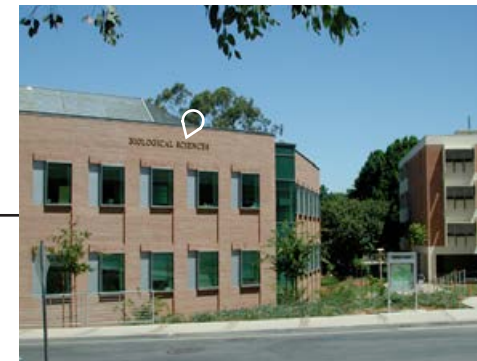
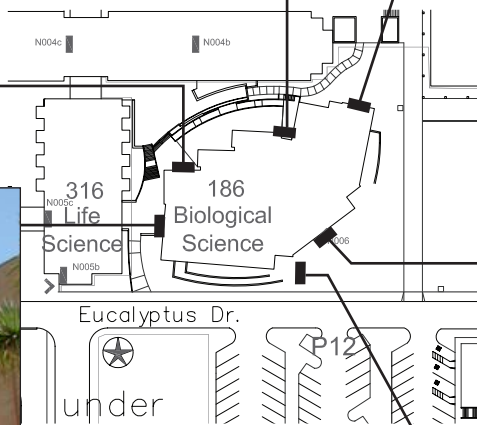

Keep existing sign

Add W50 Vehicular Bldg ID

Biomed Teaching Center (385)		qty
W50	Vehicular Bldg ID	1
W51	Freestanding, Ped	0
W52	Wall Mounted	3
W53	Vinyl Letters on Door	0
W54	Parapet Letters	0
W55	Building ID, small	1
B95	Loading Dock ID	0



Replace with W52 Wall Mounted Bldg ID



Replace with W52 Wall Mounted Bldg ID

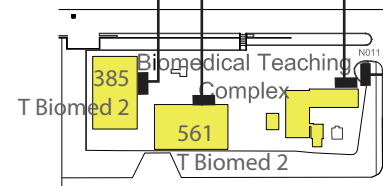

Add W55 Building ID, small



Add W52 Wall Mounted Bldg ID



Replace with W50 Vehicular Bldg ID

Bookstore (224)		qty
W50	Vehicular Bldg ID	0
W51	Freestanding, Ped	0
W52	Wall Mounted	2
W53	Vinyl Letters on Door	1
W54	Parapet Letters	2
B95	Loading Dock ID	1

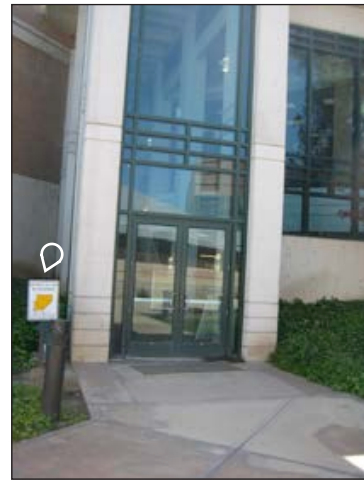

Keep Existing Sign

Add
W54 Parapet Letters



Add
W54 Parapet Letters

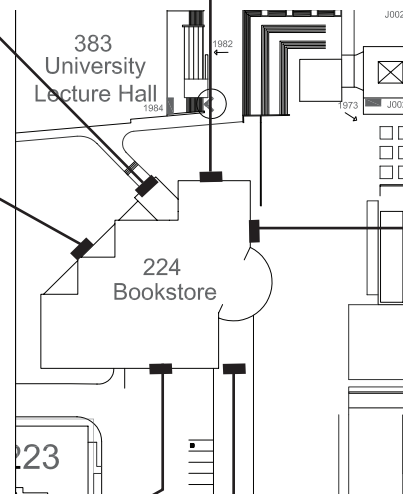

Add
W52 Wall Mounted Bldg ID



Add
W53 Vinyl Letters on Doors



Add
B95 Loading Dock ID



Add
W52 Wall Mtd Bldg ID

Botanical Gardens (254)		qty
W50	Vehicular Bldg ID	0
W51	Freestanding, Ped	0
W52	Wall Mounted	0
W53	Vinyl Letters on Door	0
W54	Parapet Letters	0
B95	Loading Dock ID	0
*Entry Sign—exception to Master Plan		1

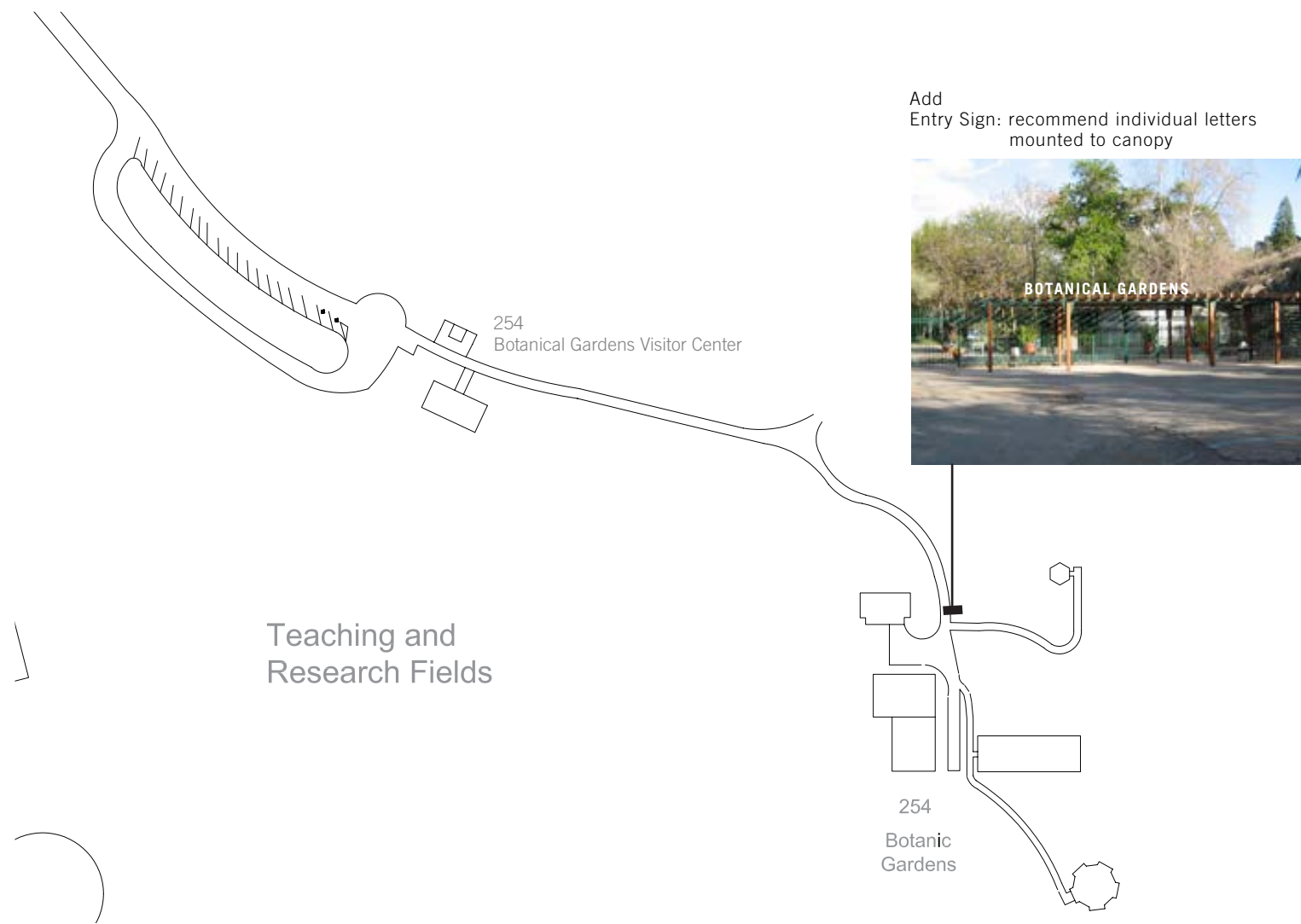

Add
Entry Sign: recommend individual letters
mounted to canopy



Bourns Hall (261)		qty
W50	Vehicular Bldg ID	1
W51	Freestanding, Ped	1
W52	Wall Mounted	5
W53	Vinyl Letters on Door	4
W54	Parapet Letters	0
B95	Loading Dock ID	0



Keep existing sign



Keep existing sign



Keep existing sign



Add W52 Wall Mounted Bldg ID



Keep existing sign
Add W53 Vinyl Letters on Door



Add W52 Wall Mounted Bldg ID

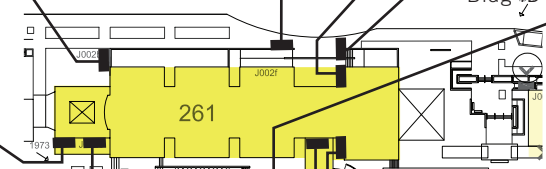

Add W52 Wall Mounted Bldg ID



Add W53 Vinyl Letters on Door



Add W52 Wall Mounted Bldg ID



Add W51 Freestanding, Ped Bldg ID

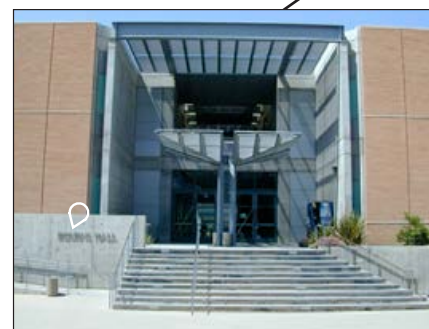

Add W53 Vinyl Letters on Door

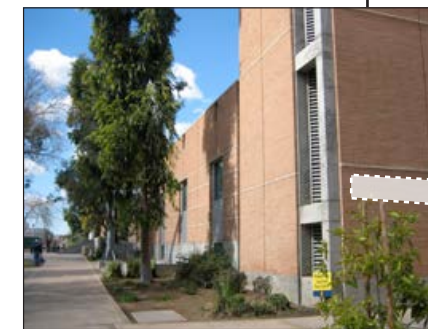

Add W52 Wall Mounted Bldg ID

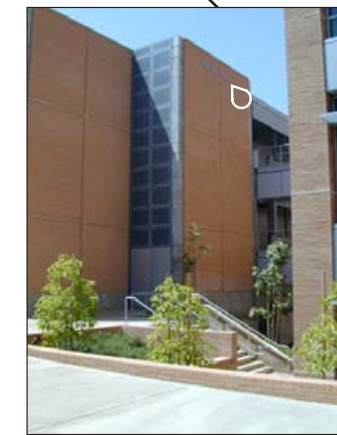

Keep existing sign



Add W53 Vinyl Letters on Door

Boyce Hall (341)		qty
W50	Vehicular Bldg ID	0
W51	Freestanding, Ped	1
W52	Wall Mounted	4
W53	Vinyl Letters on Door	4
W54	Parapet Letters	0
B95	Loading Dock ID	1



Keep existing sign

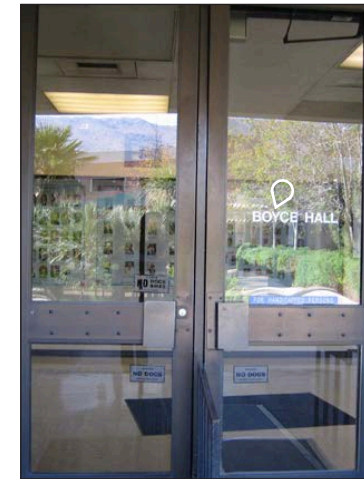

Replace with W53 Vinyl Letters on Door



Add W52 Wall Mounted Bldg ID

Replace with W53 Vinyl Letters on Door

Add W51 Ped. Bldg ID

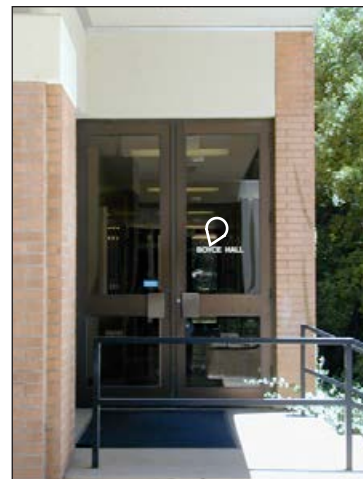

Replace with W53 Vinyl Letters on Door



Add W52 Wall Mounted Bldg ID

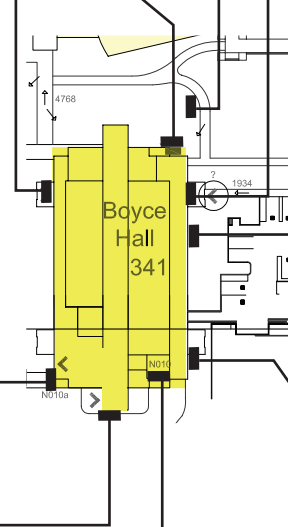

Replace with B95 Loading Dock ID

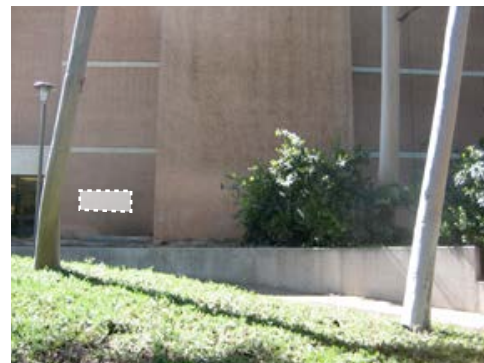

Add W52 Wall Mounted Bldg ID



Keep existing sign



Add W52 Wall Mounted Bldg ID



Replace with W53 Vinyl Letters on Door

Boyden Laboratory (482)		qty
W50	Vehicular Bldg ID	0
W51	Freestanding, Ped	1
W52	Wall Mounted	2
W53	Vinyl Letters on Door	0
W54	Parapet Letters	0
B95	Loading Dock ID	0

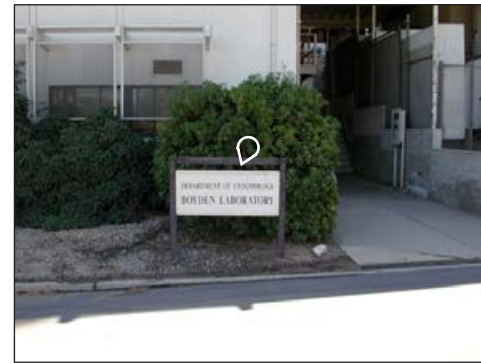

Remove existing sign

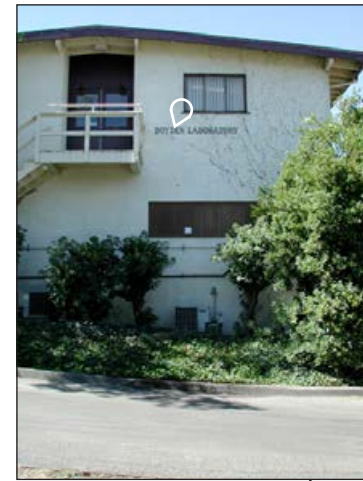

Keep existing sign

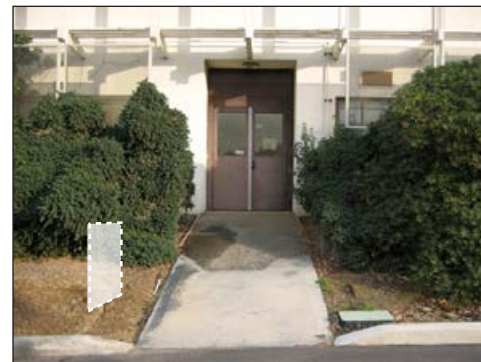

Add
W51 Freestanding Bldg ID



Add
W52 Wall Mounted Bldg ID

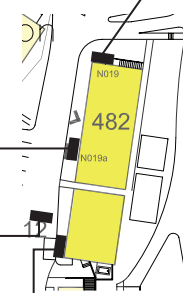

Campus Surge (380)		qty
W50	Vehicular Bldg ID	0
W51	Freestanding, Ped	1
W52	Wall Mounted	4
W53	Vinyl Letters on Door	2
W54	Parapet Letters	1
B95	Loading Dock ID	0

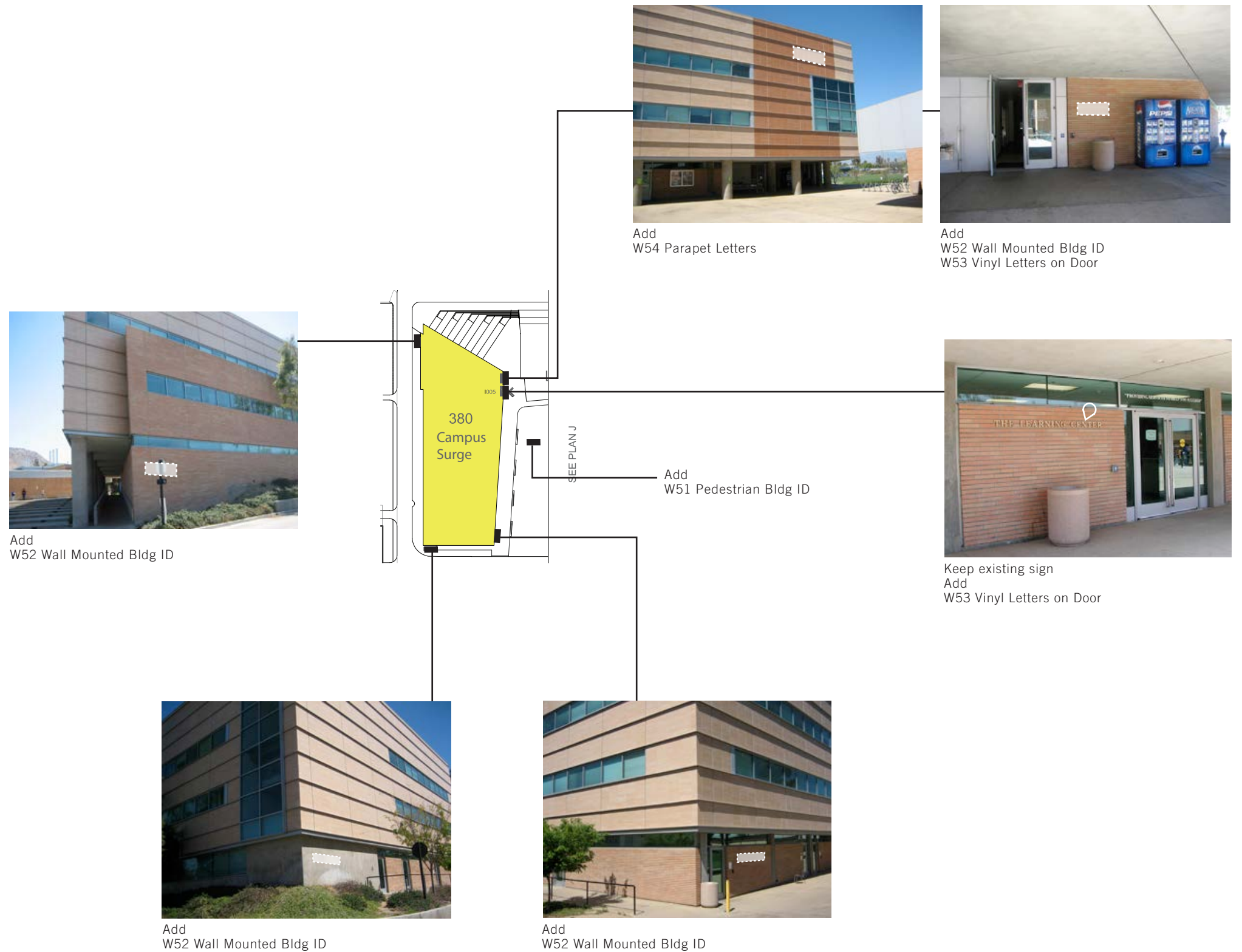

Canyon Crest Family Student Housing (000-183)		qty
W50	Vehicular Bldg ID	4
W51	Freestanding, Ped	0
W52	Wall Mounted	0
W53	Vinyl Letters on Door	0
W54	Parapet Letters	0
B95	Loading Dock ID	0

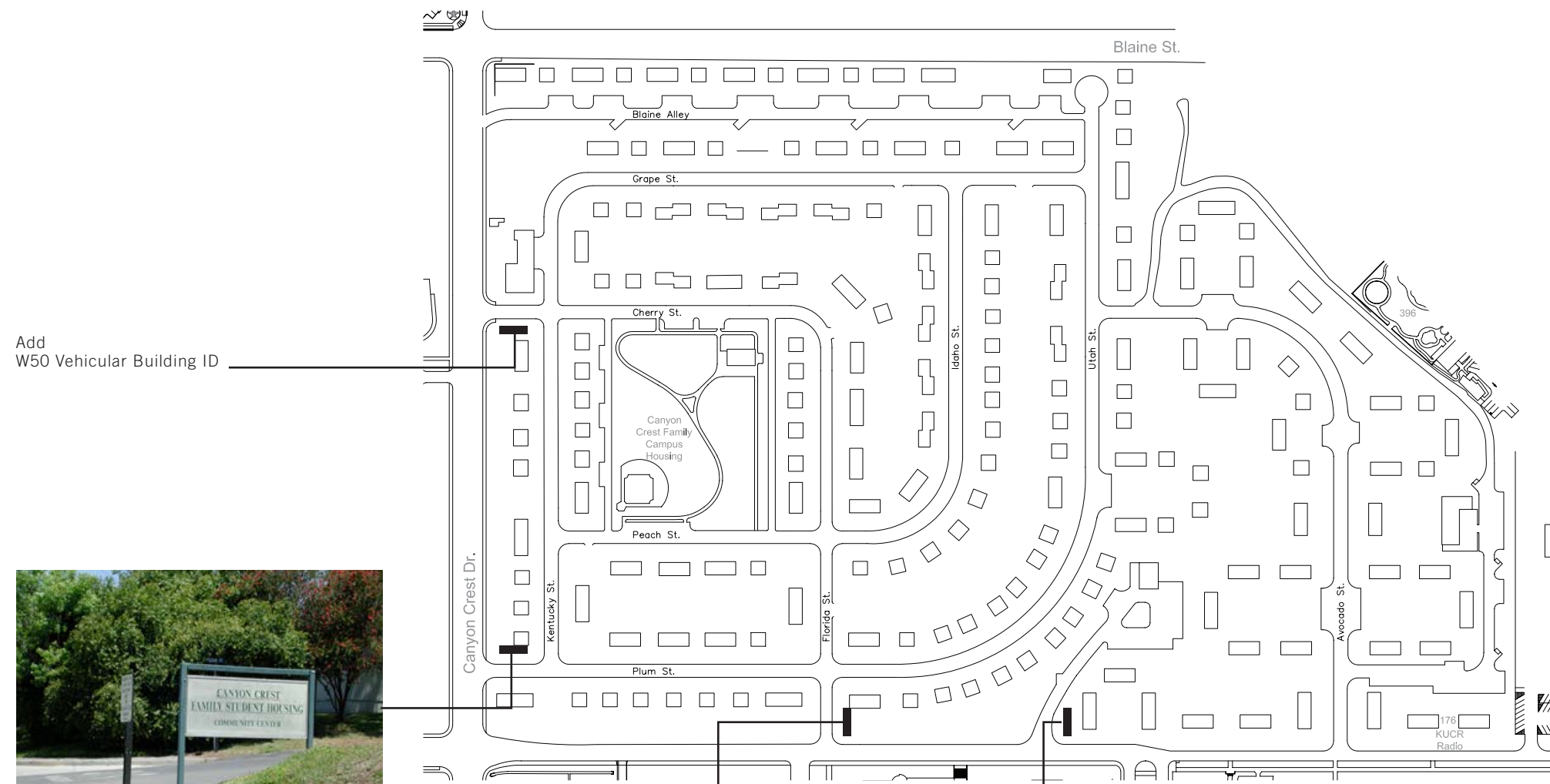

Add
W50 Vehicular Building ID



Replace with
W50 Vehicular Building ID



Add
W50 Vehicular Building ID



Replace with
W50 Vehicular Building ID

Central Utility Plant (295)		qty
W50	Vehicular Bldg ID	2
W51	Freestanding, Ped	0
W52	Wall Mounted	2
W53	Vinyl Letters on Door	0
W54	Parapet Letters	1
B95	Loading Dock ID	0



Replace with
W52 WallMounted Bldg ID



Replace with
W50 Vehicular Bldg ID



Replace with
W52 WallMounted Bldg ID



Replace with
W54 Parapet Letters

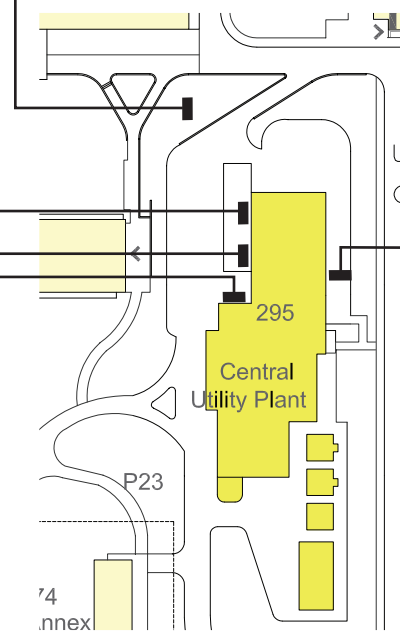

Add
W50 Vehicular Bldg ID

Chapman Hall (215)		qty
W50	Vehicular Bldg ID	0
W51	Freestanding, Ped	2
W52	Wall Mounted	0
W53	Vinyl Letters on Door	2
W54	Parapet Letters	0
B95	Loading Dock ID	0

Replace with W53 Vinyl Letters on Door



Add
W51 Freestanding, Ped

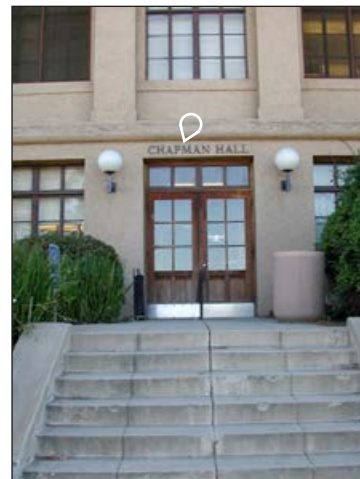

Add
W53 Vinyl Letters on Door

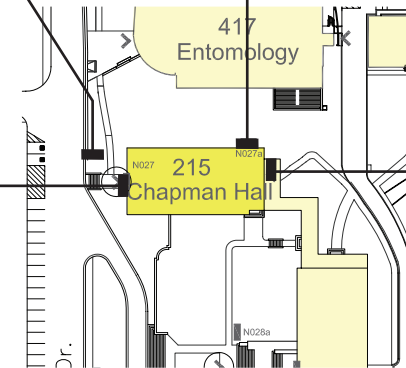

Add
W51 Freestanding Bldg ID

Chemical Sciences (414)		qty
W50	Vehicular Bldg ID	1
W51	Freestanding, Ped	0
W52	Wall Mounted	0
W53	Vinyl Letters on Door	5
W54	Parapet Letters	0
B95	Loading Dock ID	1



Replace with
W53 Vinyl Letters on Door

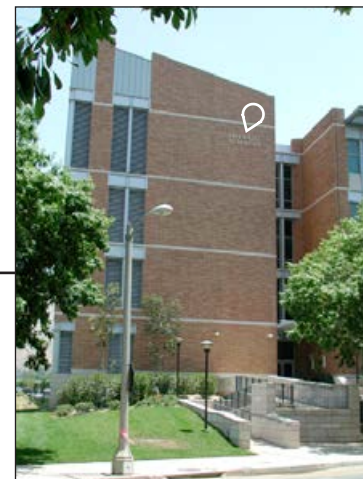

Keep existing sign



Keep existing sign
Add
B95 Loading Dock Sign



Add
W53 Vinyl Letters on Door



Add
W50 Vehicular Bldg ID

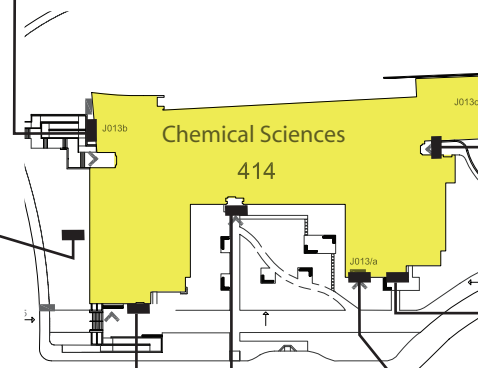

Add
W53 Vinyl Letters on Door



Replace with
W53 Vinyl Letters on Door



Add
W53 Vinyl Letters on Door



Keep existing sign

Child Dev Center (396)		qty
W50	Vehicular Bldg ID	1
W51	Freestanding, Ped	0
W52	Wall Mounted	0
W53	Vinyl Letters on Door	0
W54	Parapet Letters	0
B95	Loading Dock ID	0

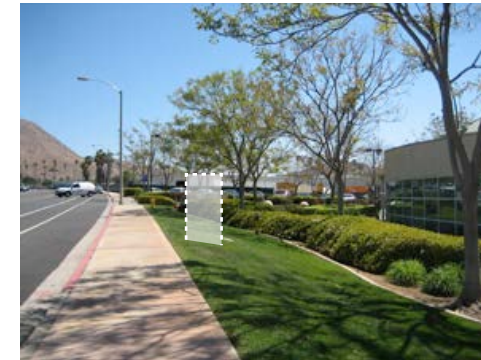

Add
W50 Vehicular Bldg ID



Remove existing sign

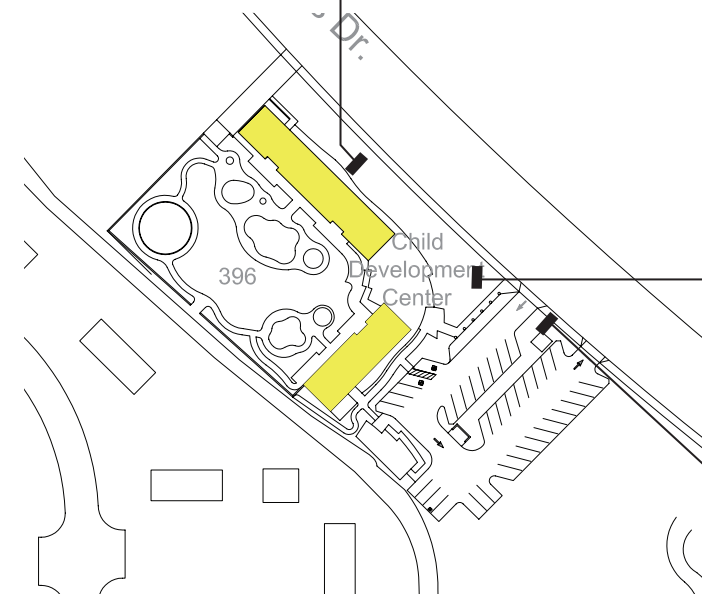

Note:
A Parking Sign (W71) with the bldg name
has been included in the sign location plan

	College Bldg North (231)	College Bldg South (517)	qty
W50	Vehicular Bldg ID		1
W51	Freestanding, Ped		1
W52	Wall Mounted Bldg ID		3
W53	Vinyl Letters on Door		2
W54	Parapet Letters		2
B95	Loading Dock ID		0



Add
W53 Vinyl Letters on Door



Add
W53 Vinyl Letters on Door



Replace with W52 Wall Mounted Bldg ID



Replace with W52 Wall Mounted Bldg ID

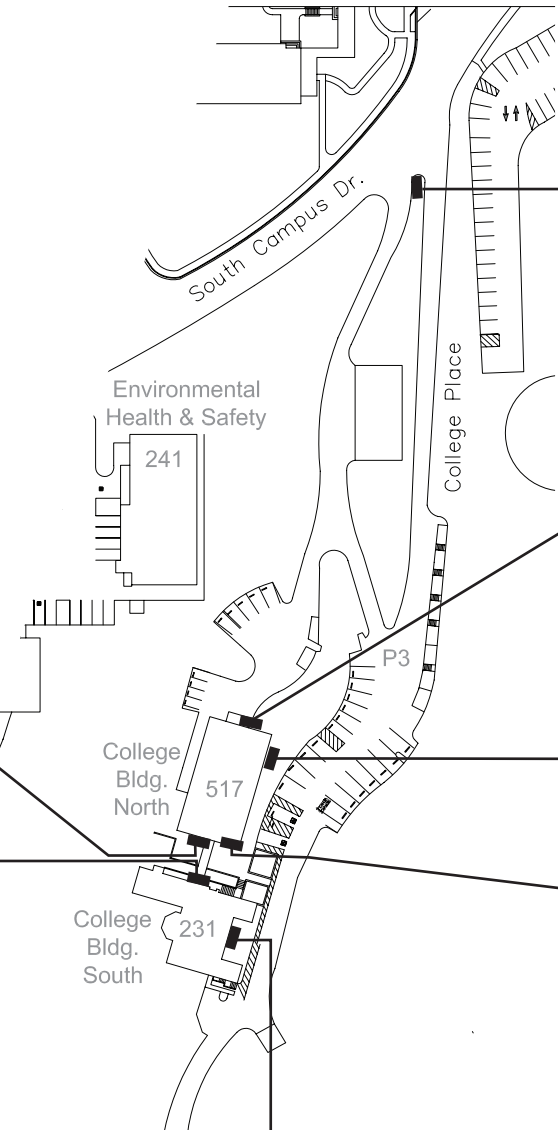

Replace with
W50 Vehicular Building ID



Add
W54 Parapet Letters



Add
W54 Parapet Letters



Add
W52 Wall Mounted Bldg ID



Keep existing sign

Computing/Comm. (381)		qty
W50	Vehicular Bldg ID	1
W51	Freestanding, Ped	0
W52	Wall Mounted	0
W53	Vinyl Letters on Door	1
W54	Parapet Letters	0
B95	Loading Dock ID	0



Keep existing sign
Add
W50 Vehicular Bldg ID

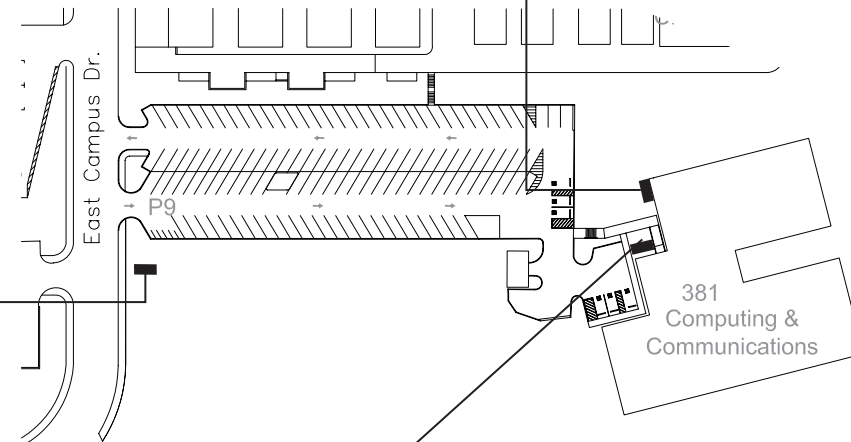

Note:
A Parking Sign (W71)
with the building name
has been included in the sign
location plan



Add
W53 Vinyl Letters on Door

Corporation Yard A-C (485-487)		qty
W50	Vehicular Bldg ID	2
W51	Freestanding, Ped	0
W52	Wall Mounted	0
W53	Vinyl Letters on Door	0
W54	Parapet Letters	0
B95	Loading Dock ID	0

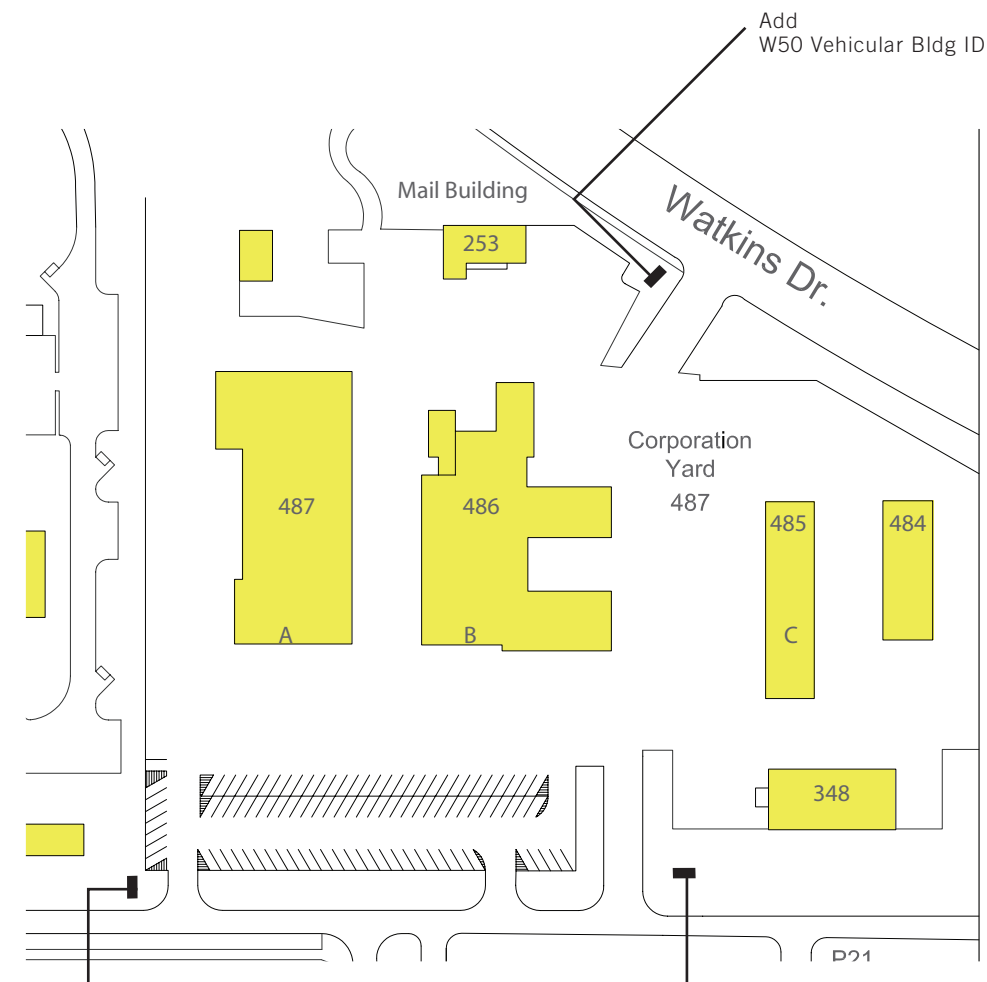

Note:
A Parking Sign (W71) with the building name has been included on the sign location plan.



Add W50 Vehicular Bldg ID

Costo Hall (311)		qty
W50	Vehicular Bldg ID	0
W51	Freestanding, Ped	1
W52	Wall Mounted	0
W53	Vinyl Letters on Door	0
W54	Parapet Letters	0
B95	Loading Dock ID	0

Note:
 Building should be surveyed again
 once the Commons Expansion
 is 100% complete.



Keep existing sign

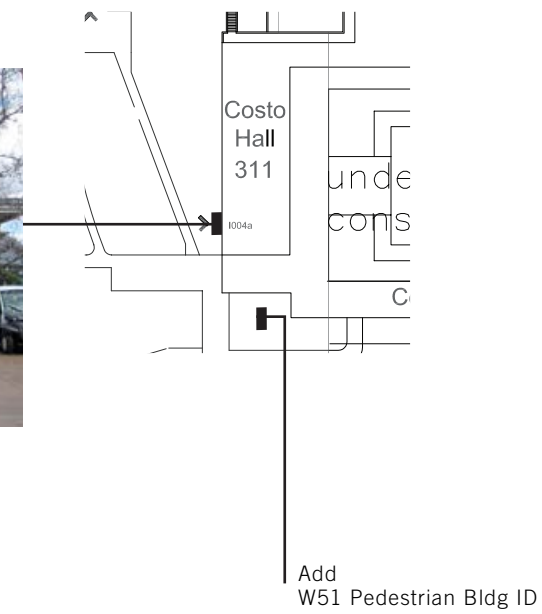

University Cottage (118)		qty
W50	Vehicular Bldg ID	1
W51	Freestanding, Ped	0
W52	Wall Mounted	0
W53	Vinyl Letters on Door	0
W54	Parapet Letters	0
B95	Loading Dock ID	0

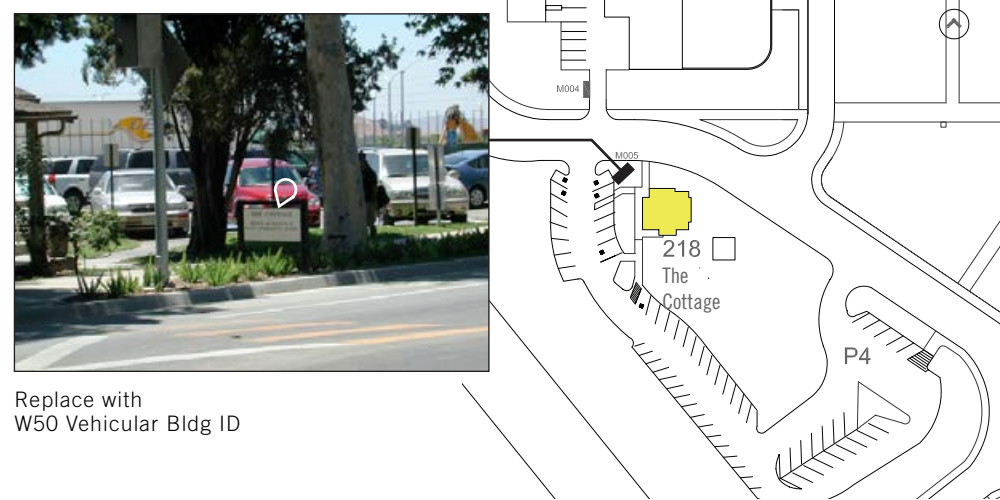

Replace with
W50 Vehicular Bldg ID

Culver Center of the Arts (757)		qty
W50	Vehicular Bldg ID	0
W51	Freestanding, Ped	0
W52	Wall Mounted	0
W53	Vinyl Letters on Door	0
W54	Parapet Letters	0

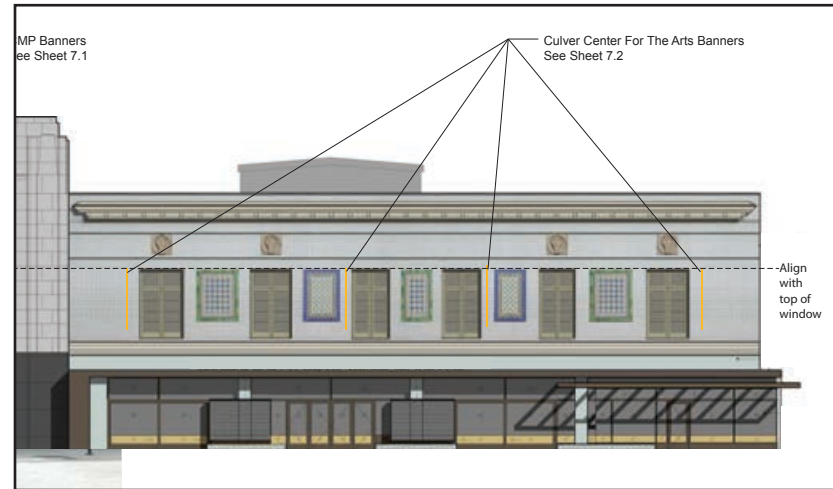

See UC Riverside ArtsBlock Signage Package for Building Identification recommendations.

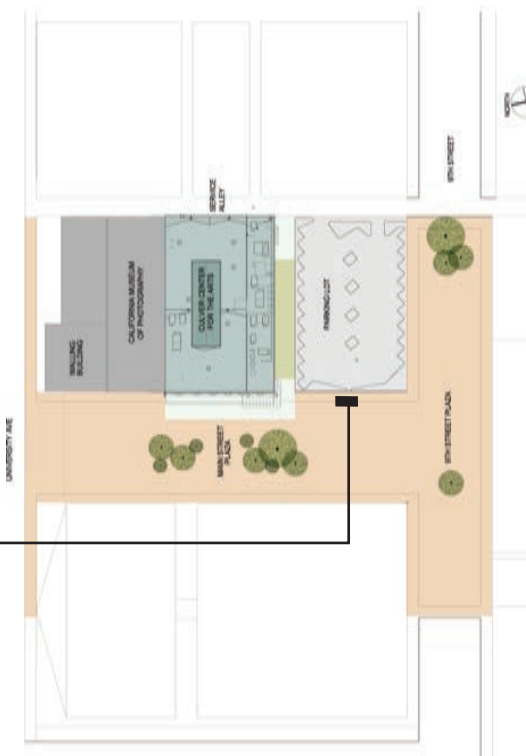

Custodial & Grounds (507)		qty
W50	Vehicular Bldg ID	1
W51	Freestanding, Ped	0
W52	Wall Mounted	0
W53	Vinyl Letters on Door	0
W54	Parapet Letters	0
B95	Loading Dock ID	0

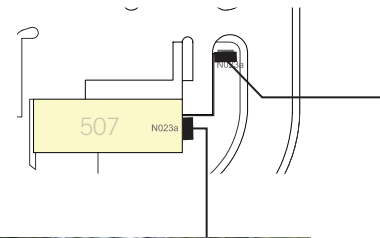

Replace with W50 Vehicular Bldg ID



Keep existing sign

Engineering Building Unit 2 (194)		qty
W50	Freestanding, Vehicular	1
W51	Freestanding, Ped	0
W52	Wall Mounted	6
W53	Vinyl Letters on Door	5
W54	Parapet Letters	0
B95	Loading Dock ID	1



Add
W52 Wall Mounted Building ID
W53 Vinyl Letters on Door



Add
W52 Wall Mounted Building ID



Keep existing sign
Add W53 Vinyl Letters on Door



Add
W52 Wall Mounted Building ID

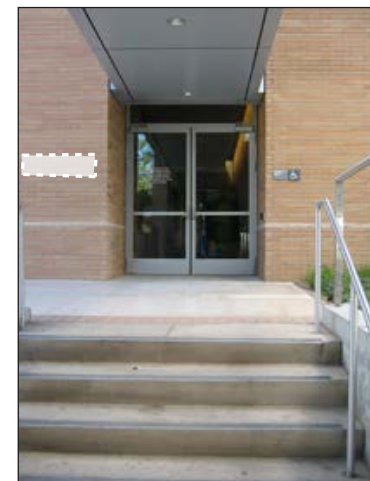

Add
W52 Wall Mounted Building ID
W53 Vinyl letters on door

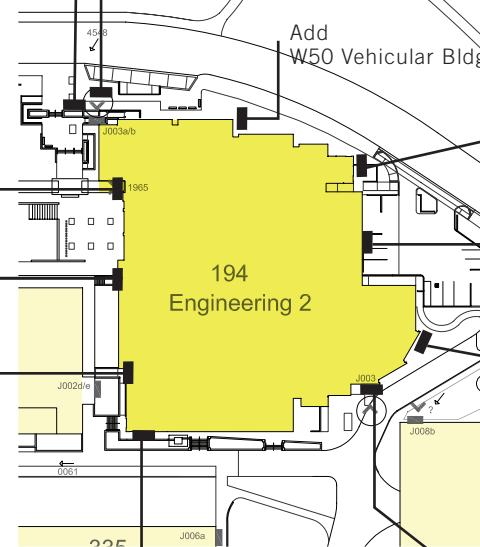

Add
W50 Vehicular Bldg ID



Add
B95 Loading Dock ID



Add
W52 Wall Mounted Building ID

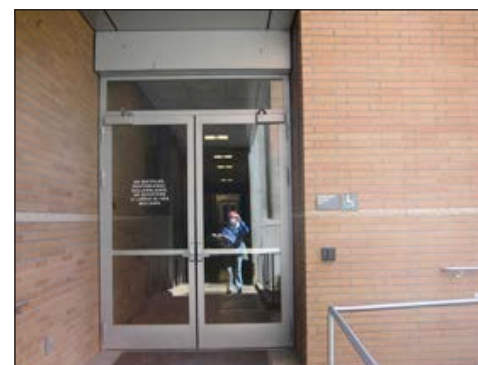

Add
W53 Vinyl letters on door



Add
W52 Wall Mounted Building ID

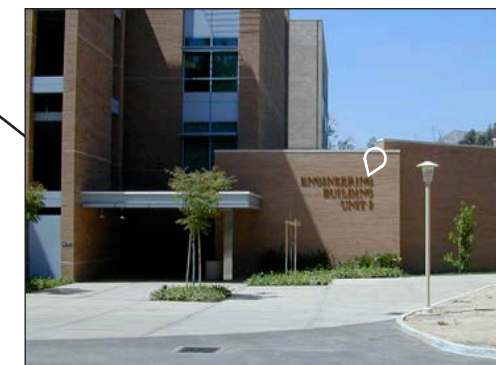

Keep existing sign
Add
W53 Vinyl letters
on door

Entomology (417)		qty
W50	Vehicle Bldg ID	1
W51	Freestanding, Ped	0
W52	Wall Mounted	3
W53	Vinyl Letters on Door	3
W54	Parapet Letters	0
B95	Loading Dock ID	1



Add
W52 Wall Mounted Bldg ID



Add
B95 Loading Dock ID



Keep existing sign

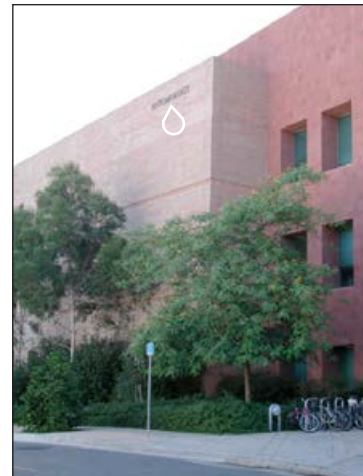

Keep existing sign

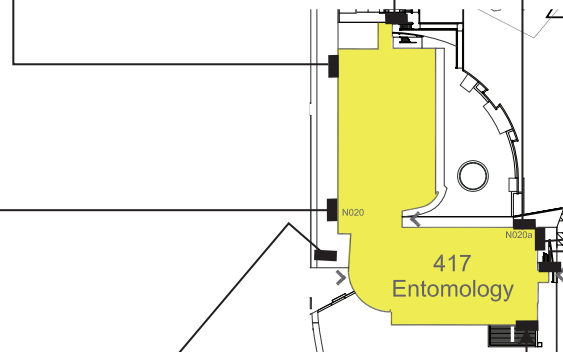

Add
W52 Wall Mounted Bldg ID
W53 Vinyl Letters on Door



Add
W50 Vehicle Bldg ID
W53 Vinyl Letters on Door



Add
W52 Wall Mounted Bldg ID



Add
W53 Vinyl Letters on Door

Entomology Museum (256)		qty
W50	Vehicular Bldg ID	0
W51	Freestanding, Ped	1
W52	Wall Mounted Bldg ID	1
W53	Vinyl Letters on Door	2
W54	Parapet Letters	0
B95	Loading Dock ID	0

Keep existing sign



Add W53 Vinyl Letters on Door



Add W51 Freestanding Bldg ID

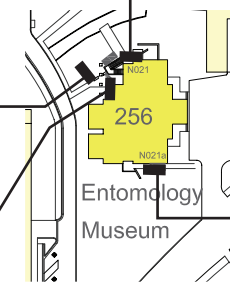

Replace with W52 Wall Mounted Bldg ID



Add W53 Vinyl Letters on Door

Env. Health & Safety (241)		qty
W50	Vehicular Bldg ID	0
W51	Freestanding, Ped	0
W52	Wall Mounted	0
W53	Vinyl Letters on Door	1
W54	Parapet Letters	1
B95	Loading Dock ID	0

Keep existing sign



Add W54 Parapet Letters

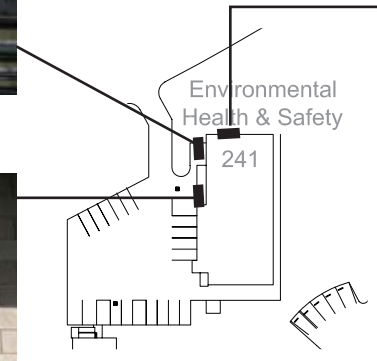

Replace with W53 Vinyl Letters on Door

Fawcett Laboratory (503)		qty
W50	Vehicular Bldg ID	2
W51	Freestanding, Ped	1
W52	Wall Mounted	1
W53	Vinyl Letters on Door	2
W54	Parapet Letters	0
B95	Loading Dock ID	1



Replace with W50 Vehicular Bldg ID



Replace with W52 Wall Mounted Bldg ID
Add W53 Vinyl Letters on Door

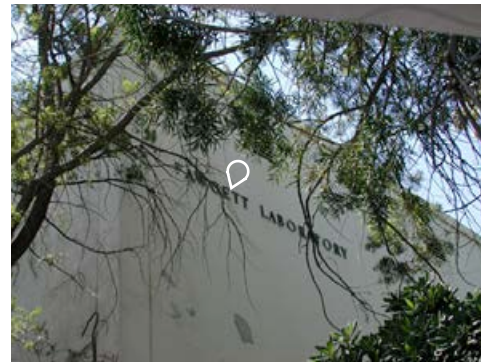

Keep existing sign

Add B95 Loading Dock ID

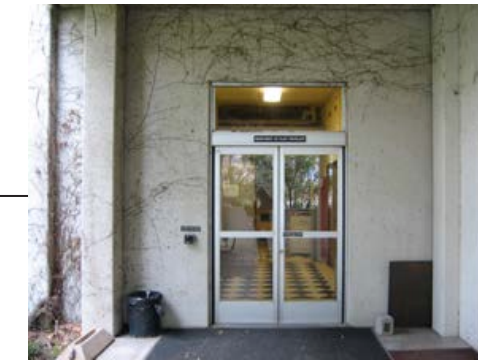
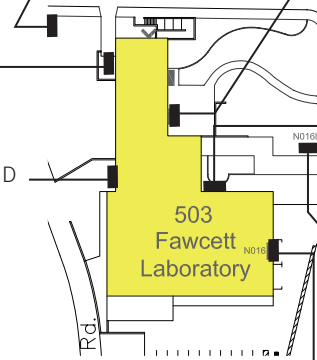

Add W53 Vinyl Letters on Door



Keep existing sign



Replace with W50 Vehicular Bldg ID

Geology (335)

	qty
W50 Vehicular Bldg ID	0
W51 Freestanding, Ped	4
W52 Wall Mounted	3
W53 Vinyl Letters on Door	4
W54 Parapet Letters	0
B95 Loading Dock ID	1



Keep existing sign
Add W53 Vinyl Letters on Door



Add
W51 Freestanding Bldg ID



Add
W51 Freestanding Bldg ID

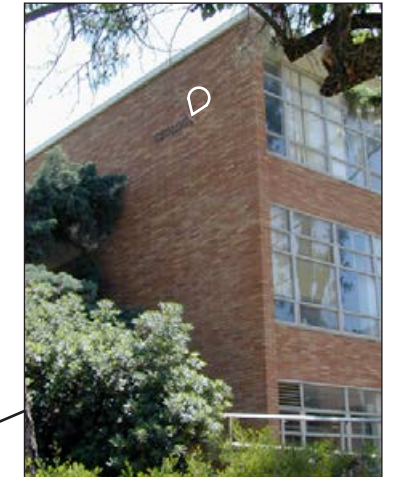

Keep existing sign

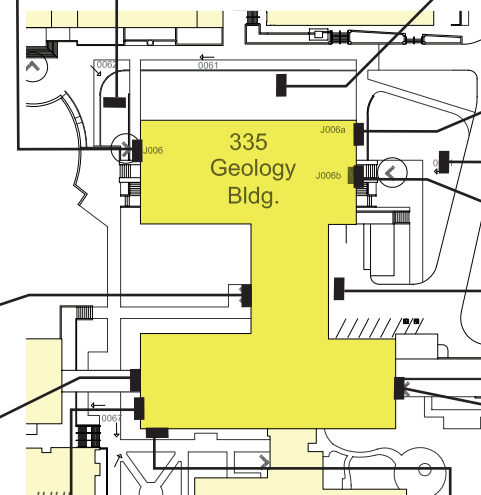

Add
Loading Dock Info



Replace
W53 Vinyl Letters on Door



Add
W51 Freestanding Bldg ID

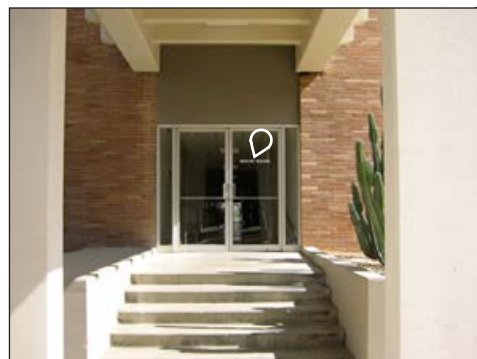

Replace
W53 Vinyl Letters on Door

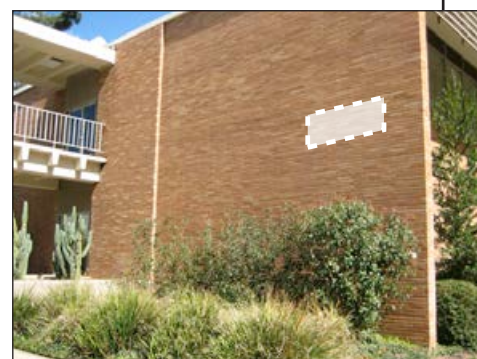

Add
W52 Wall Mounted Bldg ID



Add
W52 Wall Mounted Bldg ID
W51 Freestanding Bldg ID

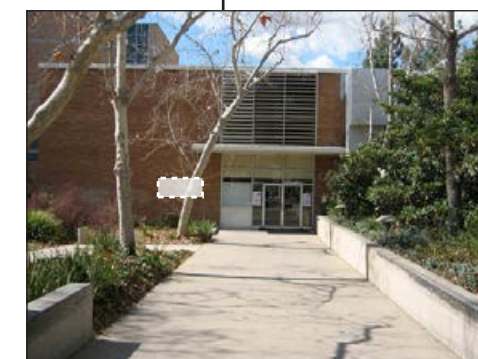

Add
W52 Wall Mounted Bldg ID

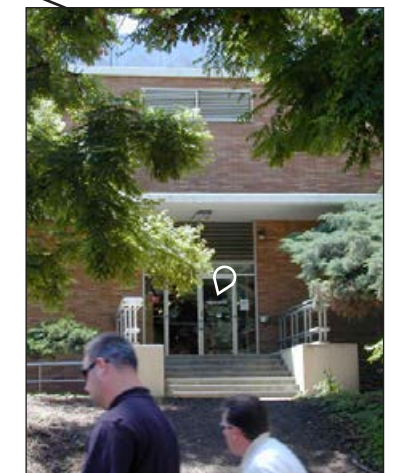

Replace
W53 Vinyl Letters on Door

Greenhouses 6-10 (200, & 275-278)		qty
W50	Vehicular Bldg ID	0
W51	Freestanding, Ped	0
W52	Wall Mounted	1
W53	Vinyl Letters on Door	0
W54	Parapet Letters	0
W55	Building ID, small	10
B95	Loading Dock ID	0



Add W55 Building ID, small



Add W55 Building ID, small



Add W55 Building ID, small



Add W55 Building ID, small



Add W55 Building ID, small



Add W55 Building ID, small

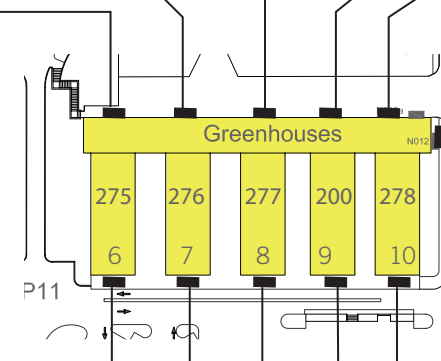

Replace with W52 Wall Mounted Bldg ID



Add W55 Building ID, small



Add W55 Building ID, small



Add W55 Building ID, small



Add W55 Building ID, small

**Greenhouses 11-14
(279-281, 481)**

	qty
W50 Vehicular Bldg ID	0
W51 Freestanding, Ped	0
W52 Wall Mounted	0
W53 Vinyl Letters on Door	0
W54 Parapet Letters	0
W55 Building ID, small	11
B95 Loading Dock ID	0



Replace with
W55 Building ID, small



Replace with
W55 Building ID, small



Replace with
W55 Building ID, small



Replace with
W55 Building ID, small



Replace with
W55 Building ID, small

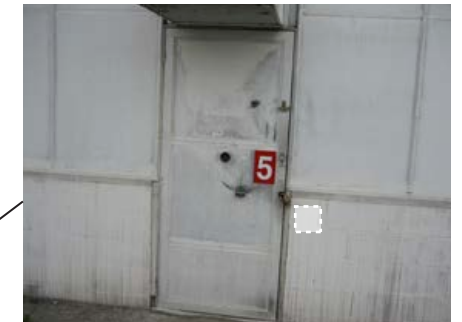

Replace with
W55 Building ID, small

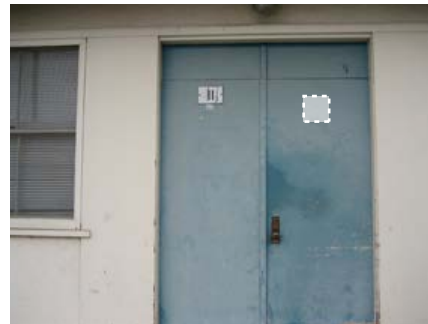

Replace with
W55 Building ID, small

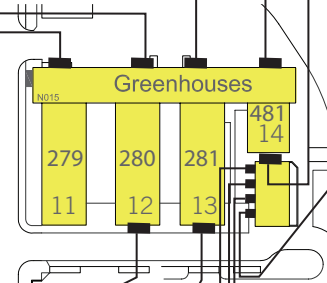

Replace with
W55 Building ID, small



Replace with
W55 Building ID, small



Replace with
W55 Building ID, small



Replace with
W55 Building ID, small

Greenhouses 15 - 21 (210, 284, 483, 513-515, & 202)		
		qty
W50	Vehicular Bldg ID	0
W51	Freestanding, Ped	0
W52	Wall Mounted	4
W53	Vinyl Letters on Door	0
W54	Parapet Letters	0
W55	Building ID, small	8
B95	Loading Dock ID	0



Replace with
W52 Wall Mounted Bldg ID



Replace with
W55 Building ID, small

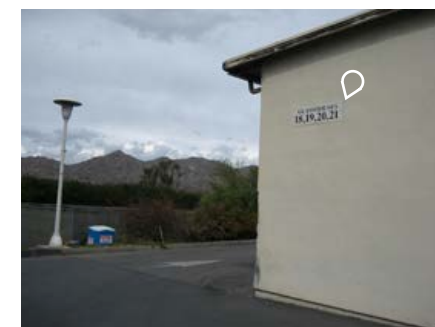

Replace with
W52 Wall Mounted Bldg ID



Replace with
W52 Wall Mounted Bldg ID



Replace with
W55 Building ID, small



Replace with
W55 Building ID, small



Replace with
W55 Building ID, small



Replace with
W55 Building ID, small



Replace with
W55 Building ID, small



Replace with
W55 Building ID, small



Replace with
W55 Building ID, small



Replace with
W52 Wall Mounted Bldg ID

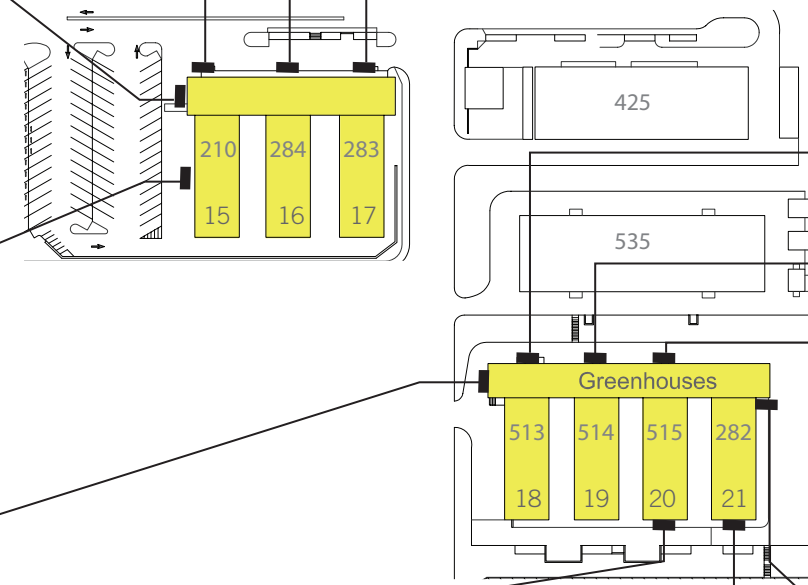

Headhouse greenhouses 1-3 (378, 259, 374)

	qty
W50 Vehicular Bldg ID	0
W51 Freestanding, Ped	0
W52 Wall Mounted	6
W53 Vinyl Letters on Door	1
W54 Parapet Letters	0
W55 Building ID, small	4
B95 Loading Dock ID	0



Replace with W52 Wall Mounted Bldg ID

Note: A Parking Sign (W71) with the building name is included in the sign location plan

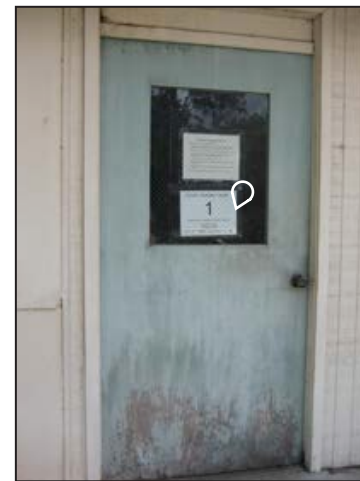

Replace with W55 Building ID, small



Replace with W55 Building ID, small



Replace with W55 Building ID, small

Replace with W52 Wall Mounted Bldg ID



Replace with W52 Wall Mounted Bldg ID

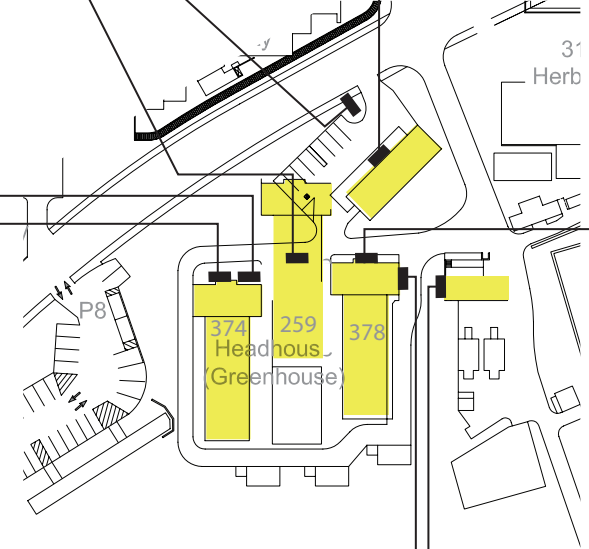

Replace with W52 Building ID, wall mounted



Replace with W52 Building ID, wall mounted



Replace with W53 Vinyl Letters on Door



Replace with W52 Building ID, wall mounted



Add W55 Building ID, small

Health Services Building (495)		qty
W50	Vehicular Bldg ID	2
W51	Freestanding, Ped	0
W52	Wall Mounted	1
W53	Vinyl Letters on Door	1
W54	Parapet Letters	0
B95	Loading Dock ID	0



Keep existing sign



Replace with W53 Vinyl Letters on Door

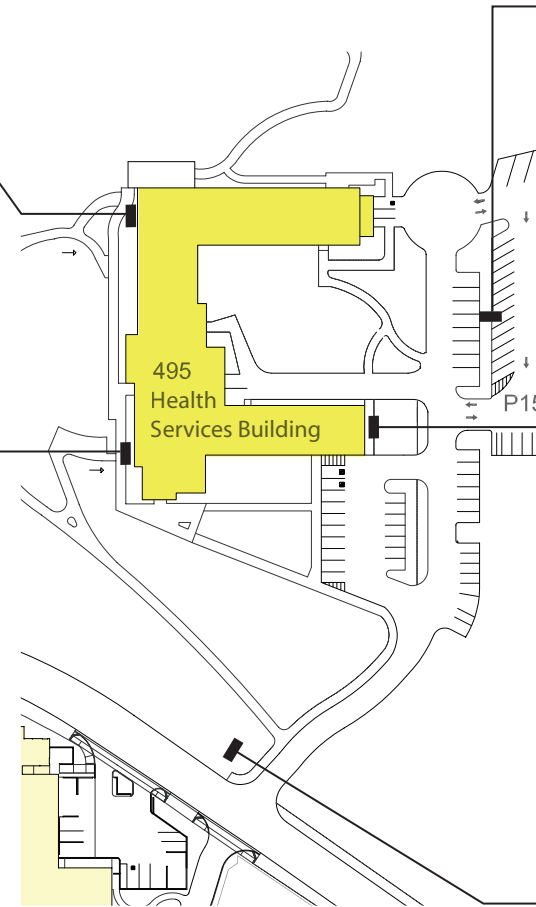

Add W50 Vehicular Bldg ID



Add W52 Wall Mounted Bldg ID

Add W50 Vehicular Building ID

Herbarium (319)		qty
W50	Vehicular Bldg ID	0
W51	Freestanding, Ped	1
W52	Wall Mounted	0
W53	Vinyl Letters on Door	0
W54	Parapet Letters	0
B95	Loading Dock ID	0



Replace with
W51 Freestanding Bldg ID

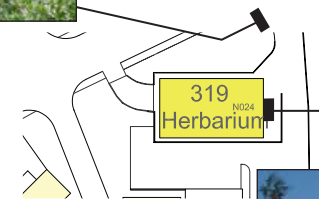

Keep existing sign

Highlander Hall (716)		qty
W50	Vehicular Bldg ID	0
W51	Freestanding, Ped	0
W52	Wall Mounted	3
W53	Vinyl Letters on Door	1
W54	Parapet Letters	0
B95	Loading Dock ID	0



Replace with W52 Wall Mounted Bldg ID



Replace with W53 Vinyl Letters on Door



Replace with W52 Wall Mounted Bldg ID

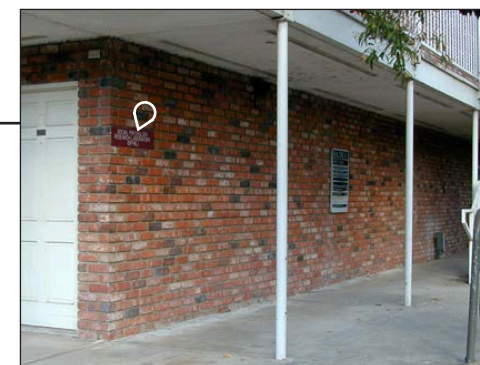
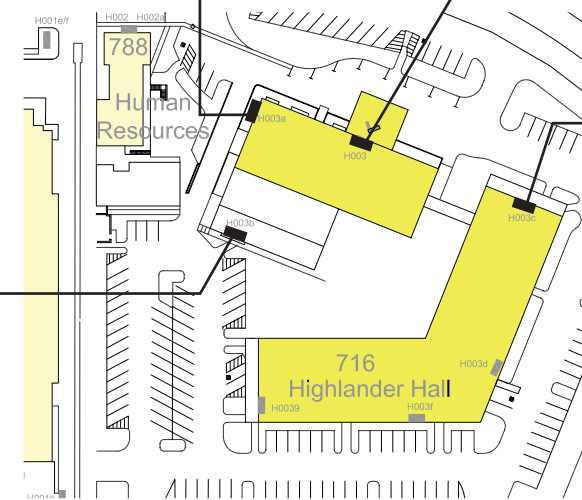

Replace with W52 Wall Mounted Bldg ID

Hinderaker Hall (480)		qty
W50	Vehicular Bldg ID	0
W51	Freestanding, Ped	1
W52	Wall Mounted	0
W53	Vinyl Letters on Door	2
W54	Parapet Letters	0
B95	Loading Dock ID	1
* (2) sets of letters to match existing		



Add
W53 Vinyl Letters on Door



Keep existing sign



Keep existing sign



Keep existing sign

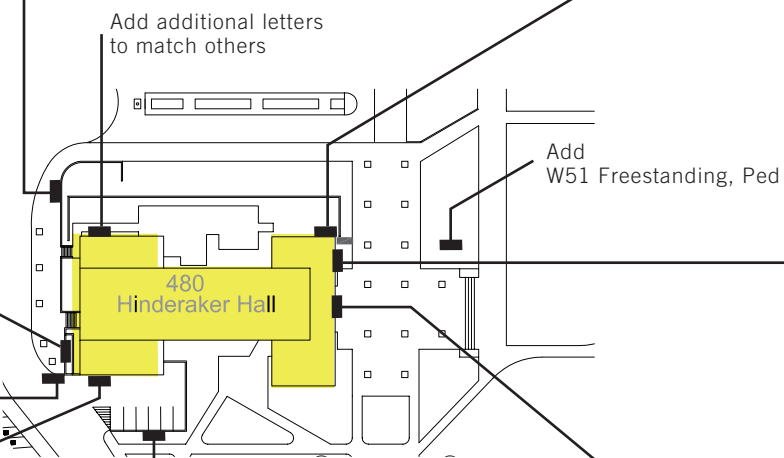

Note:
A Parking sign (W72) with the building name is included in the sign location plan.



Keep existing sign
Add
B95 Loading Dock ID



Add additional letters to match other existing sign



Add
W53 Vinyl Letters on Door

Housing Admin (581)		qty
W50	Vehicular Bldg ID	1
W51	Freestanding, Ped	0
W52	Wall Mounted	0
W53	Vinyl Letters on Door	1
W54	Parapet Letters	0
B95	Loading Dock ID	0

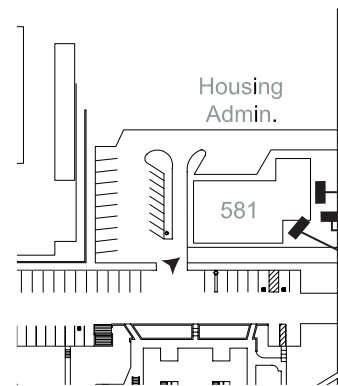

Keep existing sign
Add
W50 Vehicular Bldg ID



Add
W53 Vinyl Letters on Door

Human Resources (788)		qty
W50	Vehicular Bldg ID	1
W51	Freestanding, Ped	0
W52	Wall Mounted	0
W53	Vinyl Letters on Door	0
W54	Parapet Letters	0
B95	Loading Dock ID	0



Keep existing sign



Replace with W50 Vehicular Bldg ID

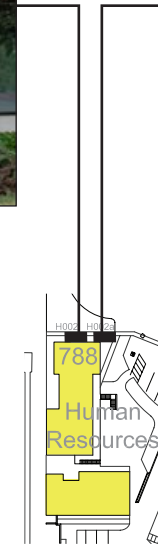

Humanities (498)		
		qty
W50	Vehicular Bldg ID	0
W51	Freestanding, Ped	1
W52	Wall Mounted	1
W53	Vinyl Letters on Door	0
W54	Parapet Letters	2
B95	Loading Dock ID	1

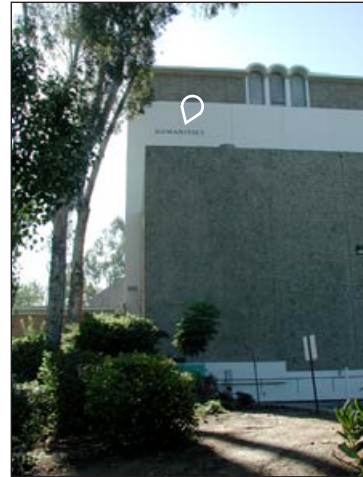

Replace with W54 Parapet Letters (University Theater)



Add B51 Freestanding Bldg ID



Add W54 Parapet Letters Keep existing sign



Add B95 Loading Dock ID

B95 Add loading dock info

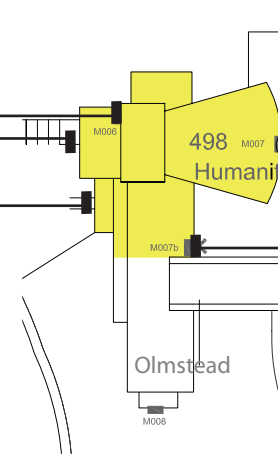

Add W52 Wall Mounted Bldg ID

Humanities & Social Sciences (307)		qty
W50	Vehicular Bldg ID	1
W51	Freestanding, Ped	1
W52	Wall Mounted	10
W53	Vinyl Letters on Door	0
W54	Parapet Letters	0
B95	Loading Dock ID	0



Add B52 Wall Mounted Bldg ID

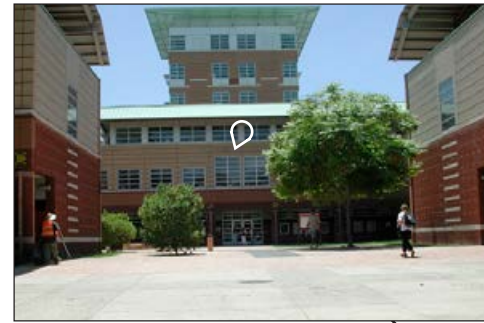

Keep existing sign



Add B52 Wall Mounted Bldg ID



Add B51 Freestanding Bldg ID



Add B52 Wall Mounted Bldg ID



Add B52 Wall Mounted Bldg ID

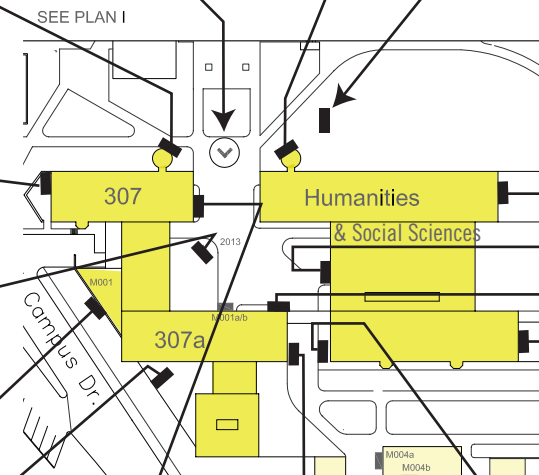

Add B52 Wall Mounted Bldg ID



Keep existing sign

Add B50 Vehicular Bldg ID



Add B52 Wall Mounted Bldg ID



Keep existing sign



Add B52 Wall Mounted Bldg ID



Add B52 Wall Mounted Bldg ID



Add B52 Wall Mounted Bldg ID

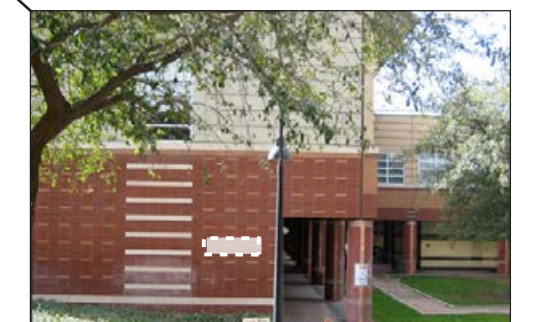

Add B52 Wall Mounted Bldg ID

East Campus Insectary & Quarantine (289)		qty
W50	Vehicular Bldg ID	0
W51	Freestanding, Ped	0
W52	Wall Mounted	0
W53	Vinyl Letters on Door	1
W54	Parapet Letters	0
B95	Loading Dock ID	1



Add W53 Vinyl Letters on Door

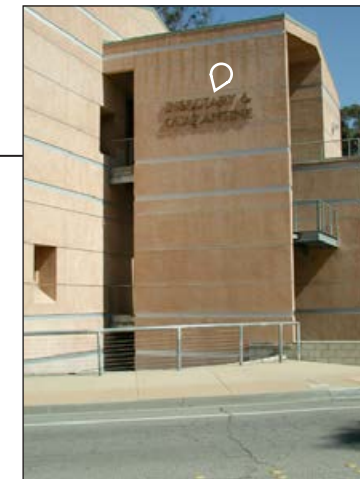
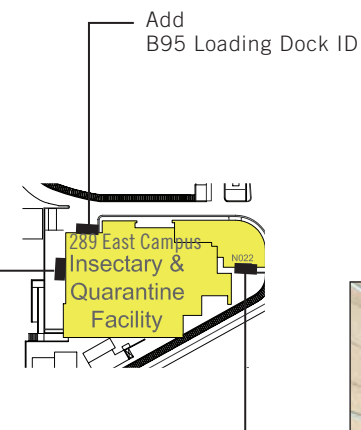

Keep existing sign

International Village (998)		qty
W50	Vehicular Bldg ID	1
W51	Freestanding, Ped	0
W52	Wall Mounted	0
W53	Vinyl Letters on Door	1
W54	Parapet Letters	0
B95	Loading Dock ID	0

* Replace wall monument sign with new sign with current brand



Replace with
New sign to match current brand



Add
W50 Vehicular Bldg ID

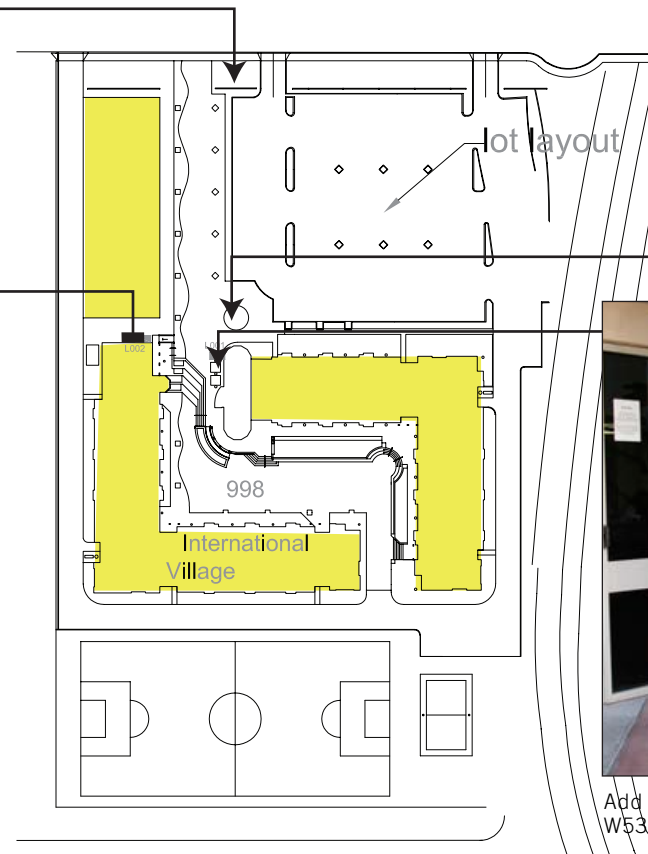

Keep existing sign



Add
W53 Vinyl Letters on Door

KUCR Radio Station (176)		qty
W50	Vehicular Bldg ID	1
W51	Freestanding, Ped	0
W52	Wall Mounted	0
W53	Vinyl Letters on Door	0
W54	Parapet Letters	1
B95	Loading Dock ID	0

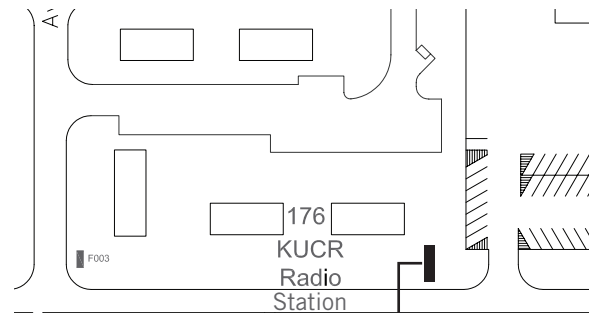

Replace existing sign with
W50 Vehicular Building ID
W54 Parapet Letters

Life Sciences (316)		qty
W50	Vehicular Bldg ID	0
W51	Freestanding, Ped	0
W52	Wall Mounted	3
W53	Vinyl Letters on Door	6
W54	Parapet Letters	2
B95	Loading Dock ID	1

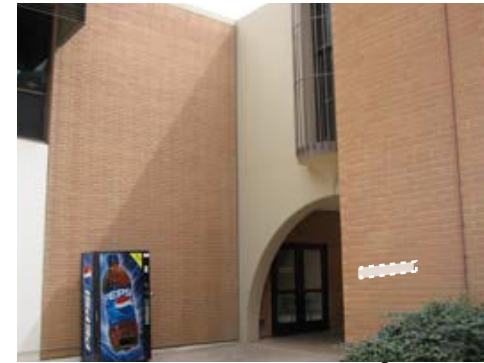

Add
W52 Wall Mounted Bldg ID
W53 Vinyl Letters on Door



Replace with
W53 Vinyl Letters on Door



Replace with
W53 Vinyl Letters on Door



Add
W53 Vinyl Letters on Sidelight

Add
B95 Loading Dock ID



Add
W54 Parapet Letters

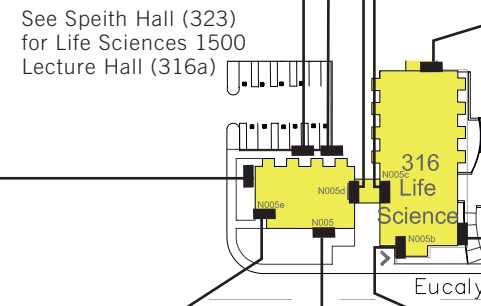

Add
W54 Parapet Letters



Add
W53 Vinyl Letters on Door



Add
W52 Wall Mounted Bldg ID

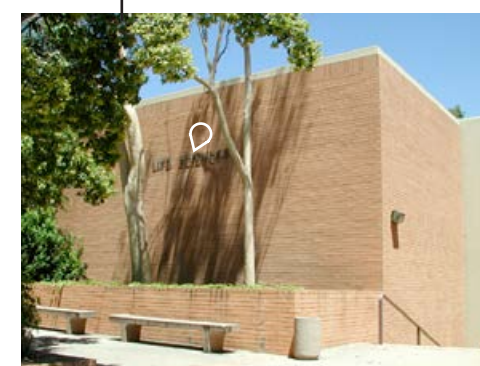

Keep existing sign



Add
W52 Wall Mounted Bldg ID



Replace with
W53 Vinyl Letters on Door

Lothian Res. Hall (502)		qty
W50	Vehicular Bldg ID	0
W51	Freestanding, Ped	0
W52	Wall Mounted	1
W53	Vinyl Letters on Door	0
W54	Parapet Letters	0
B95	Loading Dock ID	0



Add
W52 Wall Mounted Bldg ID

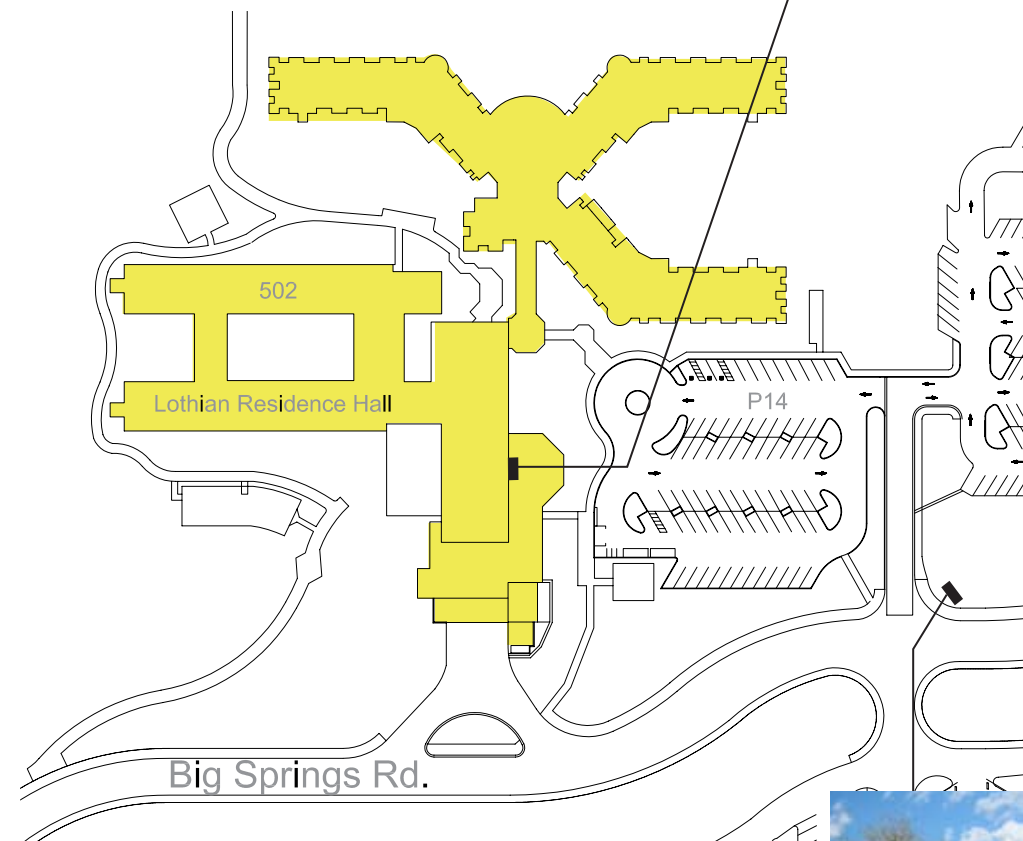

Remove Existing sign
Note: A Parking Sign (W70) with the bldg name is included in the sign location plan

Olmsted Hall (497)		
		qty
W50	Vehicular Bldg ID	0
W51	Freestanding, Ped	1
W52	Wall Mounted	3
W53	Vinyl Letters on Door	5
W54	Parapet Letters	0
B95	Loading Dock ID	0

Architectural site plan of Olmsted Hall (497) with callouts to various photos showing proposed signage locations. The plan includes labels for Humanities (498), Olmsted Hall (497), P23, and Steam (Ce) Utility. Photos show existing and proposed signage for vinyl letters on doors and wall-mounted building IDs.



Add W53 Vinyl Letters on Door



Keep existing sign



Add W51 Freestanding Bldg ID



Add W52 Wall Mounted Bldg ID



Replace with W53 Vinyl Letters on Door



Add W52 Wall Mounted Bldg ID



Add W53 Vinyl Letters on Door



Keep existing sign



Add W53 Vinyl Letters on Door



Replace with W53 Vinyl Letters on Door

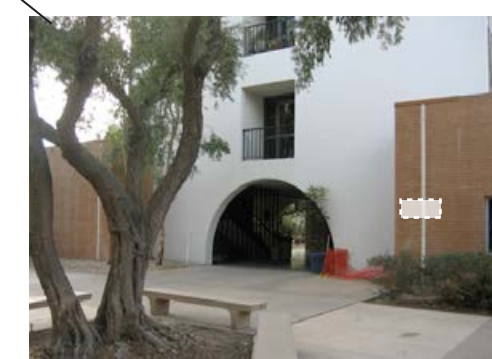

Add W52 Wall Mounted Bldg ID

Parking Services Building (272)		
		qty
W50	Vehicular Bldg ID	1
W51	Freestanding, Ped	
W52	Wall Mounted	0
W53	Vinyl Letters on Door	1
W54	Parapet Letters	0
B95	Loading Dock ID	0

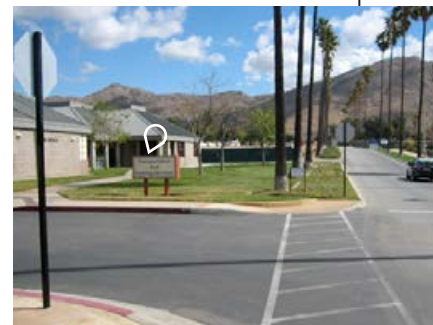
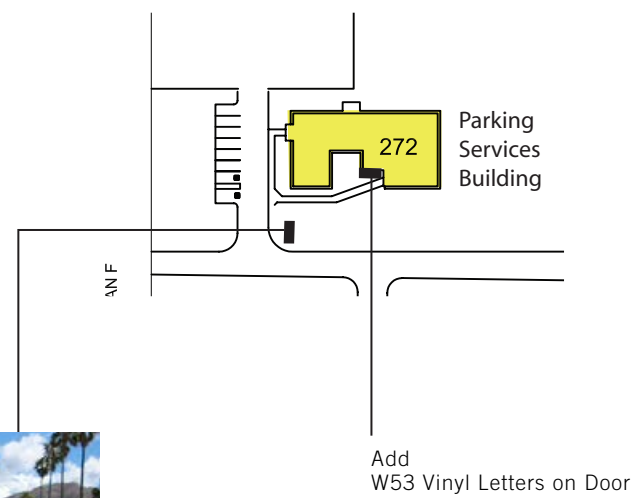

Replace with W50 Vehicular Bldg ID

Pentland Hills Residence Hall A-Q (365, 369, 636-648)(365)		
		qty
W50	Vehicular Bldg ID	2
W51	Freestanding, Ped	0
W52	Wall Mounted	0
W53	Vinyl Letters on Door	0
W54	Parapet Letters	0
B95	Loading Dock ID	0

No additional signs

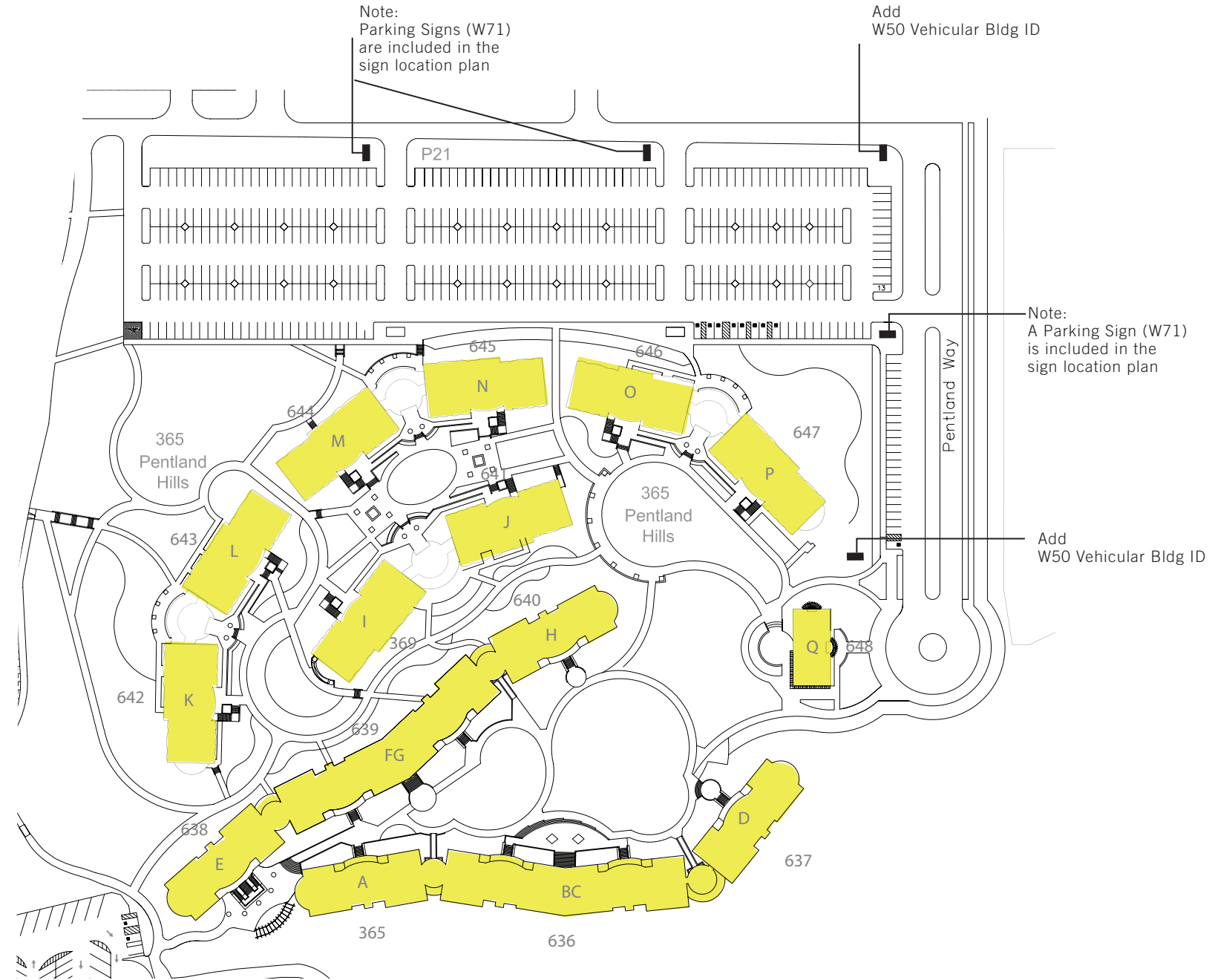

Physics (504)

	qty
W50 Vehicular Bldg ID	1
W51 Freestanding, Ped	0
W52 Wall Mounted	7
W53 Vinyl Letters on Door	3
W54 Parapet Letters	0
B95 Loading Dock ID	1

The diagram shows a site plan of the Physics Building (504) with yellow callouts pointing to specific areas. Surrounding the plan are several photographs of the building's exterior and interior, each with a white dashed box indicating a proposed signage location. The callouts are as follows:

- Top-left photo: Add W52 Wall Mounted Bldg ID
- Top-middle-left photo: Add W52 Wall Mounted Bldg ID
- Top-middle-right photo: Add W52 Wall Mounted Bldg ID, Add W50 Vehicular Bldg ID
- Top-right photo: Add W53 Vinyl Letters on Door
- Right side photo (top): Add B95 Loading Dock Id
- Right side photo (middle): Keep existing sign, Add W52 Wall Mounted Bldg ID
- Right side photo (bottom): Add W52 Wall Mounted Bldg ID
- Bottom-right photo: Add W52 Wall Mounted Bldg ID
- Bottom-middle-right photo: Add W53 Vinyl Letters on Door
- Bottom-middle photo: Keep existing sign
- Bottom-left photo: Add W53 Vinyl Letters on Door
- Bottom-left photo (top): Add W52 Wall Mounted Bldg ID
- Bottom-left photo (middle): Add W52 Wall Mounted Bldg ID
- Bottom-left photo (bottom): Add W52 Wall Mounted Bldg ID
- Center-right text: See Physics 2000 (504A) for Lecture Hall Signs

Physics 2000 Lecture Hall(504a)		qty
W50	Vehicular Bldg ID	0
W51	Freestanding, Ped	1
W52	Wall Mounted	4
W53	Vinyl Letters on Door	0
W54	Parapet Letters	1
B95	Loading Dock ID	0



Add
W52 Wall Mounted Bldg ID



Add
W52 Wall Mounted Bldg ID

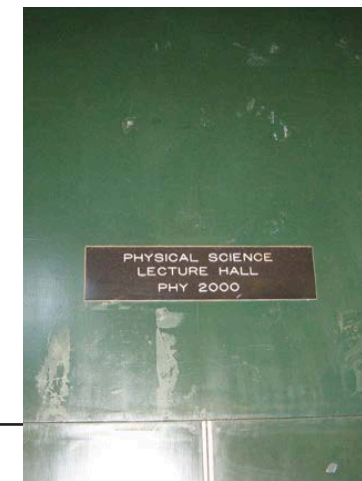

Add
W51 Freestanding Bldg ID

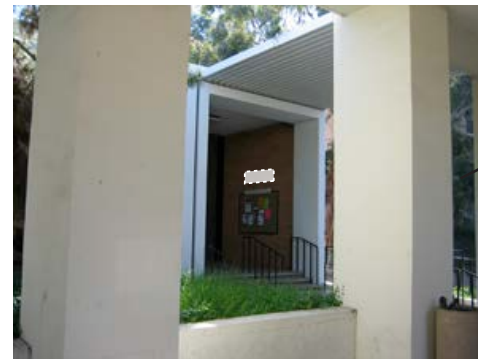
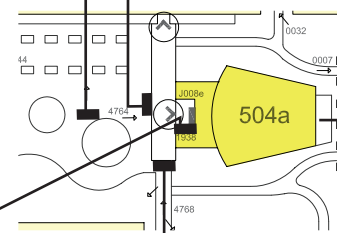

Add
W52 Wall Mounted Bldg ID



Add
W54 Parapet Letters



Add
W52 Wall Mounted Bldg ID

Phys Ed Bldg (334)		qty
W50	Vehicular Bldg ID	0
W51	Freestanding, Ped	1
W52	Wall Mounted	0
W53	Vinyl Letters on Door	1
W54	Parapet Letters	0
B95	Loading Dock ID	0

Building Signage should be reviewed once construction is completed in this area.

Keep existing sign

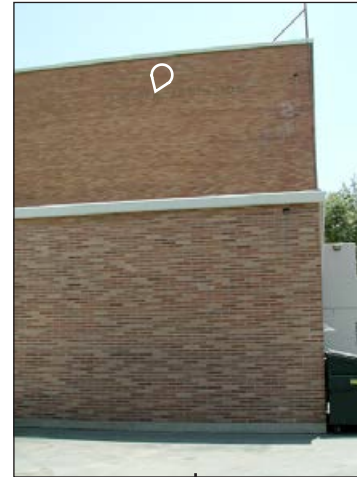

Keep existing sign

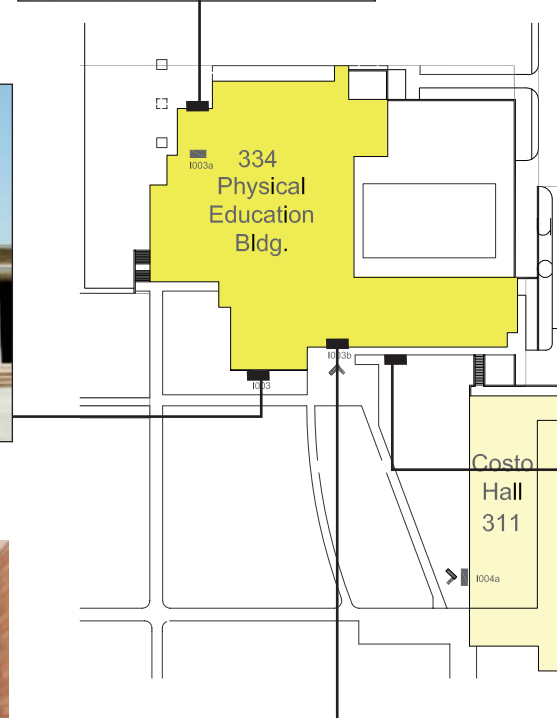

Add B51 Freestanding Bldg ID



Replace

Pierce Hall (508)		
		qty
W50	Vehicular Bldg ID	0
W51	Freestanding, Ped	1
W52	Wall Mounted	3
W53	Vinyl Letters on Door	3
W54	Parapet Letters	0
B95	Loading Dock ID	1



Add
W51 Freestanding Bldg ID



Add
B95 Loading Dock ID



Add
W52 Wall Mounted Bldg ID



Add
W52 Wall Mounted Bldg ID

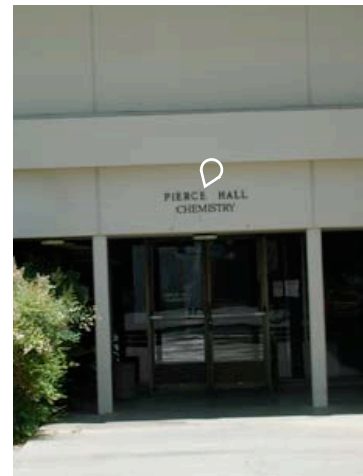

Keep existing sign
Add
W53 Vinyl Letters on Door

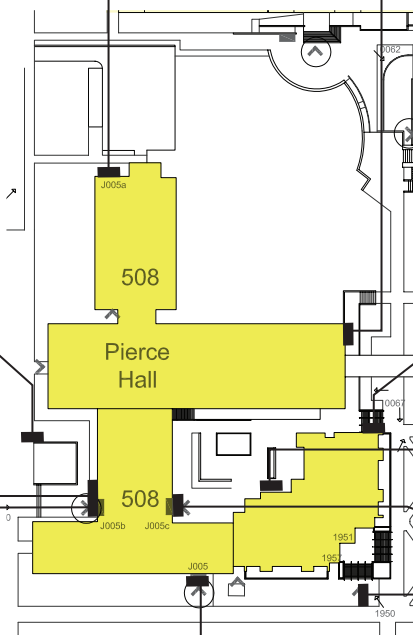

Add
W53 Vinyl Letters on Door



Add
W52 Wall Mounted Bldg ID



Keep existing sign



Add
W51 Freestanding Bldg ID

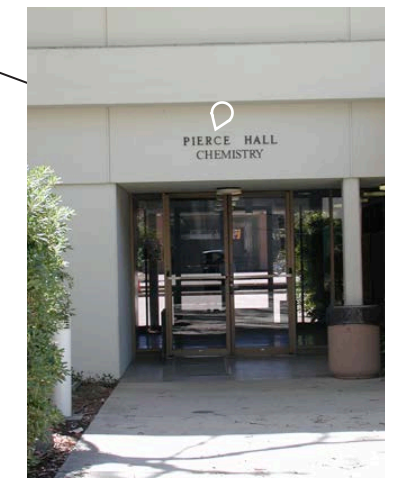

Keep existing sign "Pierce Hall"
Remove "Chemistry"
Add W53 Vinyl Letters on Door

Police Building (566)		qty
W50	Vehicular Bldg ID	1
W51	Freestanding, Ped	0
W52	Wall Mounted	0
W53	Vinyl Letters on Door	0
W54	Parapet Letters	0
B95	Loading Dock ID	0



Keep existing sign

Note:
A Monument Sign for the Campus is included on the sign location plan

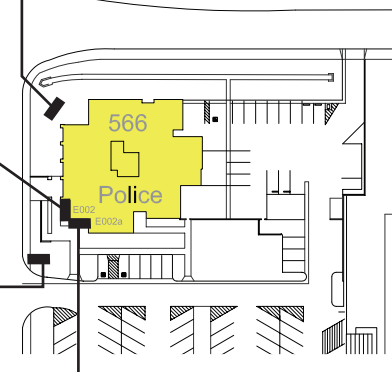

Add
W50 Vehicular Bldg ID



Keep existing sign

Riviera Library (322)		qty
W50	Vehicular Bldg ID	0
W51	Freestanding, Ped	2
W52	Wall Mounted	2
W53	Vinyl Letters on Door	2
W54	Parapet Letters	0
B95	Loading Dock ID	1



Keep existing sign



Add W51 Freestanding Bldg ID



Add W52 Wall Mounted Bldg ID (ceiling hung)

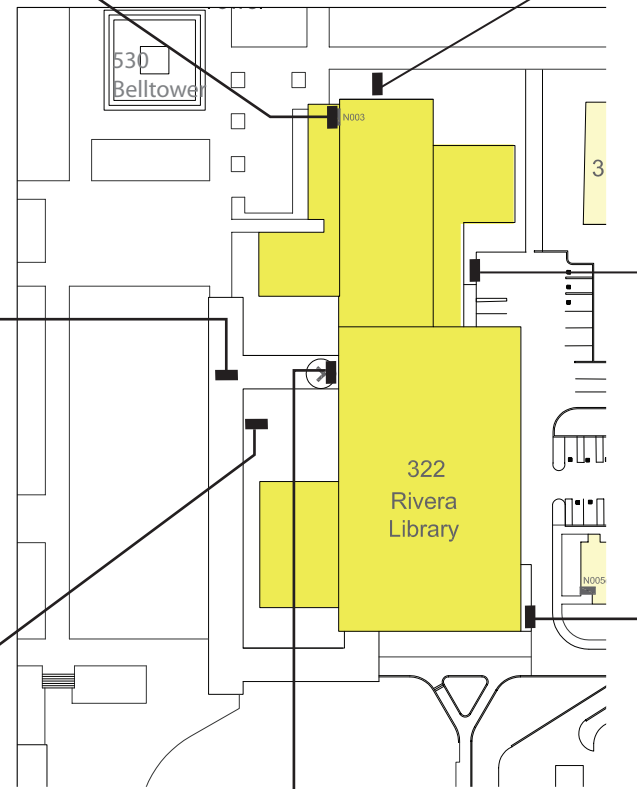

Replace with B95 Loading Dock ID

Add W51 Freestanding Bldg ID



Add W53 Vinyl Letters on Door



Add W53 Vinyl Letters on Door

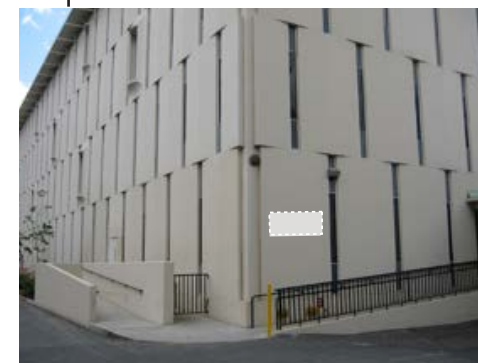

Add W52 Wall Mounted Bldg ID

Satellite Chiller Plant (367)		qty
W50	Vehicular Bldg ID	0
W51	Freestanding, Ped	0
W52	Wall Mounted	0
W53	Vinyl Letters on Door	0
W54	Parapet Letters	0
B95	Loading Dock ID	0

No signs proposed

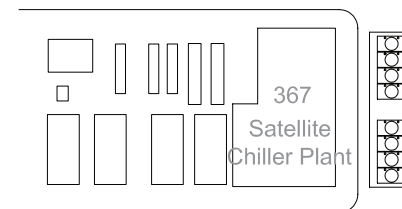

Science Laboratories 1 (416)		qty
W50	Vehicular Bldg ID	0
W51	Freestanding, Ped	1
W52	Wall Mounted	2
W53	Vinyl Letters on Door	5
W54	Parapet Letters	0
B95	Loading Dock ID	0



Add W53 Vinyl Letters on Door

Add W52 Wall Mounted ID



Keep existing sign



Add W53 Vinyl Letters on Door

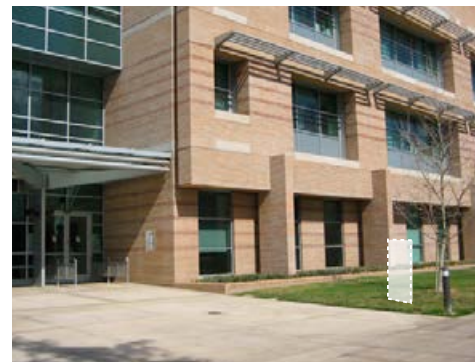

Add W51 Freestanding Bldg ID
W53 Vinyl Letters on Door

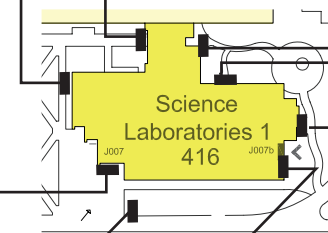

Add W52 Wall Mounted ID

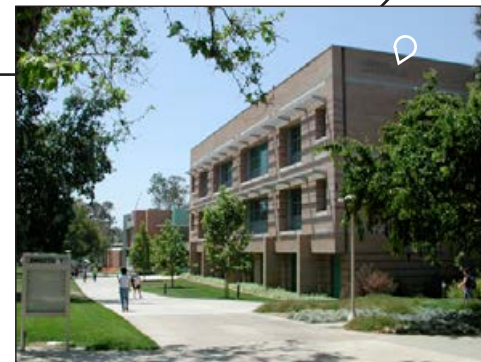

Keep existing sign

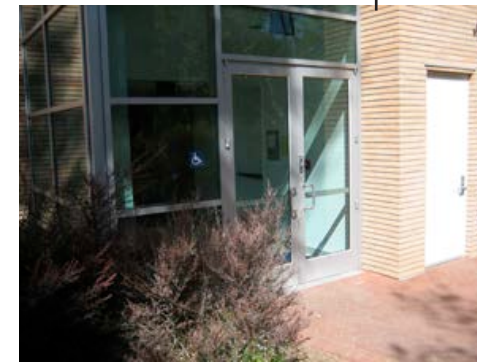

Add W53 Vinyl Letters on Door



Add W53 Vinyl Letters on Door

Science Library (418)		qty
W50	Vehicular Bldg ID	1
W51	Freestanding, Ped	1
W52	Wall Mounted	4
W53	Vinyl Letters on Door	1
W54	Parapet Letters	0
B95	Loading Dock ID	1



Add
W52 Wall Mounted Bldg ID



Add
B95 Loading Dock Info



Add
W52 Wall Mounted Bldg ID

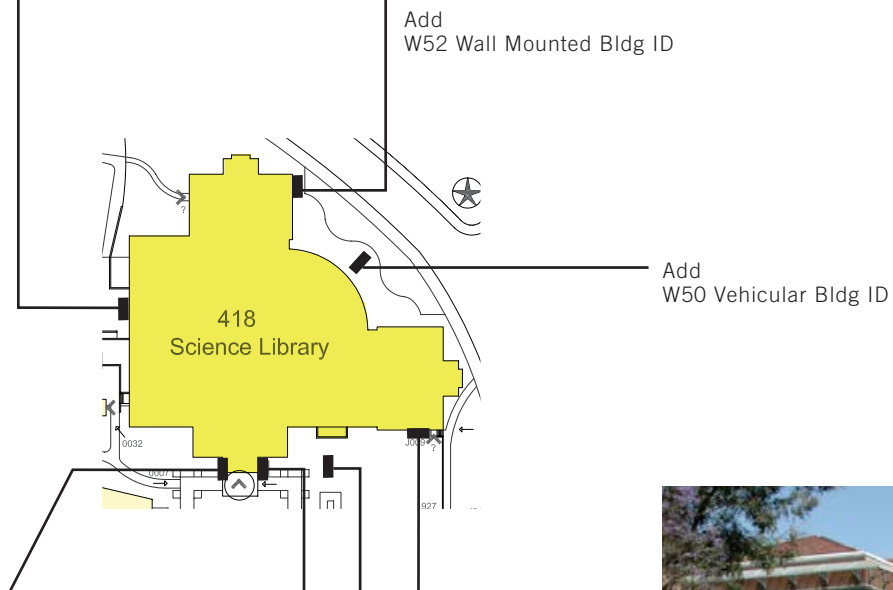

Add
W50 Vehicular Bldg ID

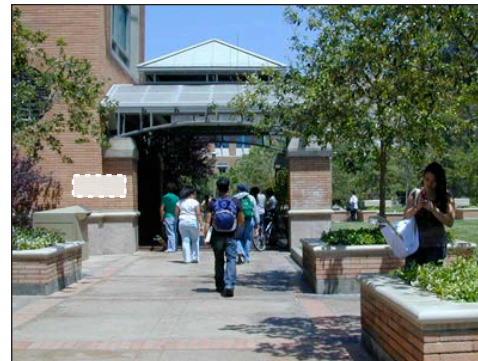

Add
W52 Wall Mounted Bldg ID
W53 Vinyl Letters on Door

Add
W52 Wall Mounted Bldg ID

Add
W51 Freestanding Bldg ID

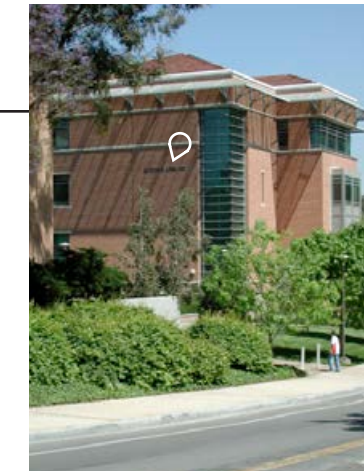

Keep existing sign

Speith Hall (323)		qty
W50	Vehicular Bldg ID	0
W51	Freestanding, Ped	1
W52	Wall Mounted	5
W53	Vinyl Letters on Door	3
W54	Parapet Letters	0
B95	Loading Dock ID	0



Replace with W53 Vinyl Letters on Door



Keep existing sign



Add W51 Freestanding Bldg ID



Add W52 WallMounted Bldg ID



Keep existing sign



Add W52 WallMounted Bldg ID

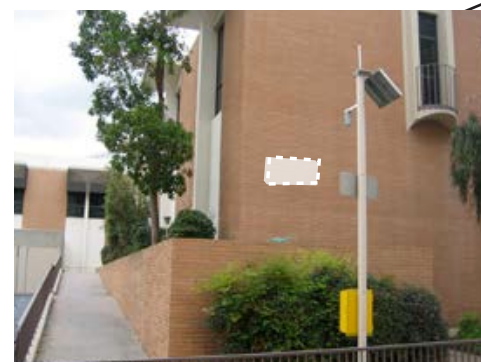
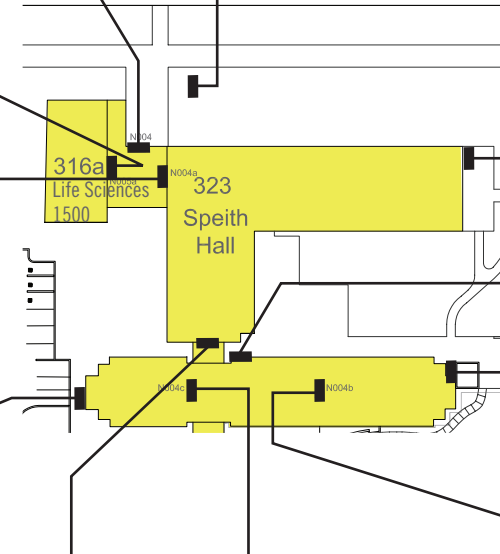

Add W52 WallMounted Bldg ID

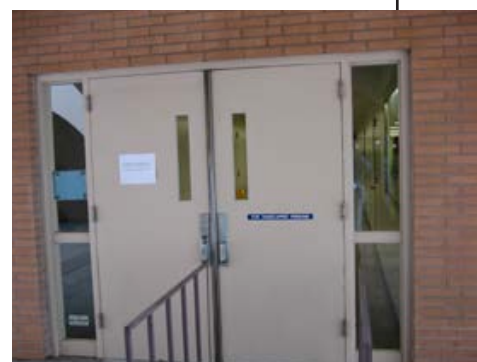

Replace with W52 WallMounted Bldg ID

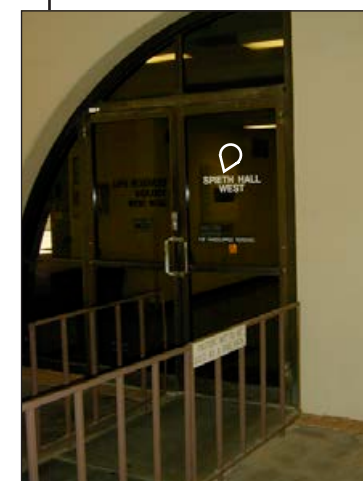

Replace with W53 Vinyl Letters on Door



Replace with W53 Vinyl Letters on Door



Add W52 WallMounted Bldg ID

Sproul Hall (523)

		qty
W50	Vehicular Bldg ID	0
W51	Freestanding, Ped	1
W52	Wall Mounted	3
W53	Vinyl Letters on Door	4
W54	Parapet Letters	0
B95	Loading Dock ID	1

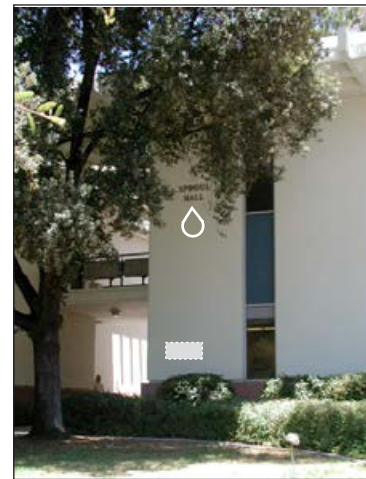

Keep existing sign
Add
W52 Wall Mounted Bldg ID



Keep existing sign



Replace with
W53 Vinyl Letters on Door

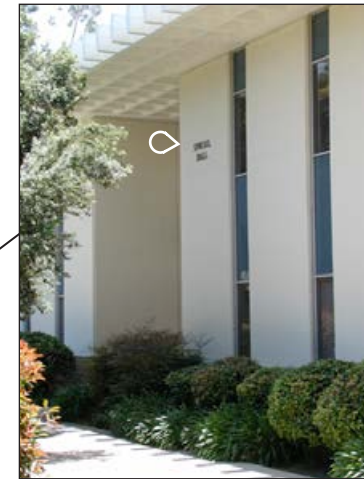

Add
W51 Freestanding
Bldg ID



Keep existing sign
Add
W52 Wall Mounted Bldg ID



Add
B95 Loading Dock ID

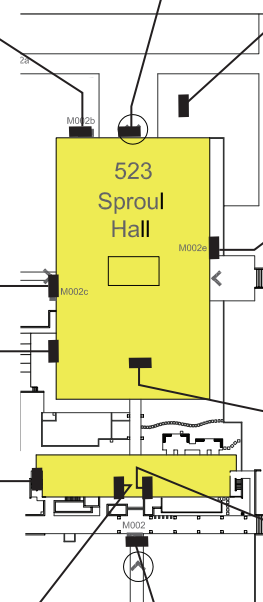

Add
W53 Vinyl Letters on Door



Add
W52 Wall Mounted Bldg ID



Add
W53 Vinyl Letters on Door

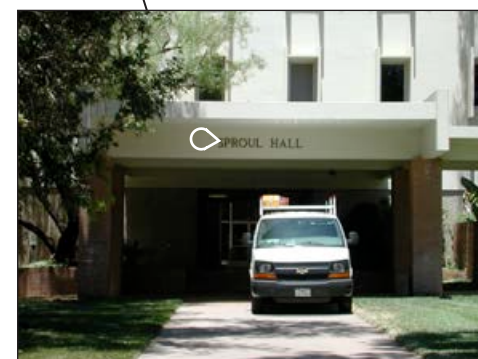

Keep existing sign



Add
W53 Vinyl Letters on Door

Statistic Computer Building (588)		qty
W50	Vehicular Bldg ID	1
W51	Freestanding, Ped	1
W52	Wall Mounted	3
W53	Vinyl Letters on Door	3
W54	Parapet Letters	0
B95	Loading Dock ID	0



Keep existing sign



Add W52 Wall Mounted Bldg ID

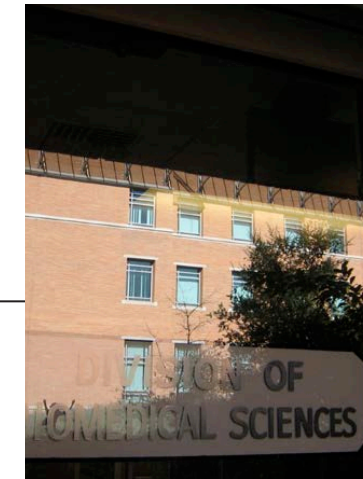

Replace with W53 Vinyl Letters on Door



Add W52 Wall Mounted Bldg ID

Add W51 Freestanding Bldg ID

Add W50 Vehicular Bldg ID



Add W53 Vinyl Letters on Door



Add W52 Wall Mounted Bldg ID
W53 Vinyl Letters on Door

Add B95 Loading Dock ID



Keep existing sign

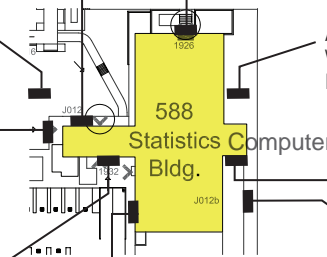

Stonehaven Apts. (991)		qty
W50	Vehicular Bldg ID	2
W51	Freestanding, Ped	0
W52	Wall Mounted	0
W53	Vinyl Letters on Door	0
W54	Parapet Letters	0
B95	Loading Dock ID	0

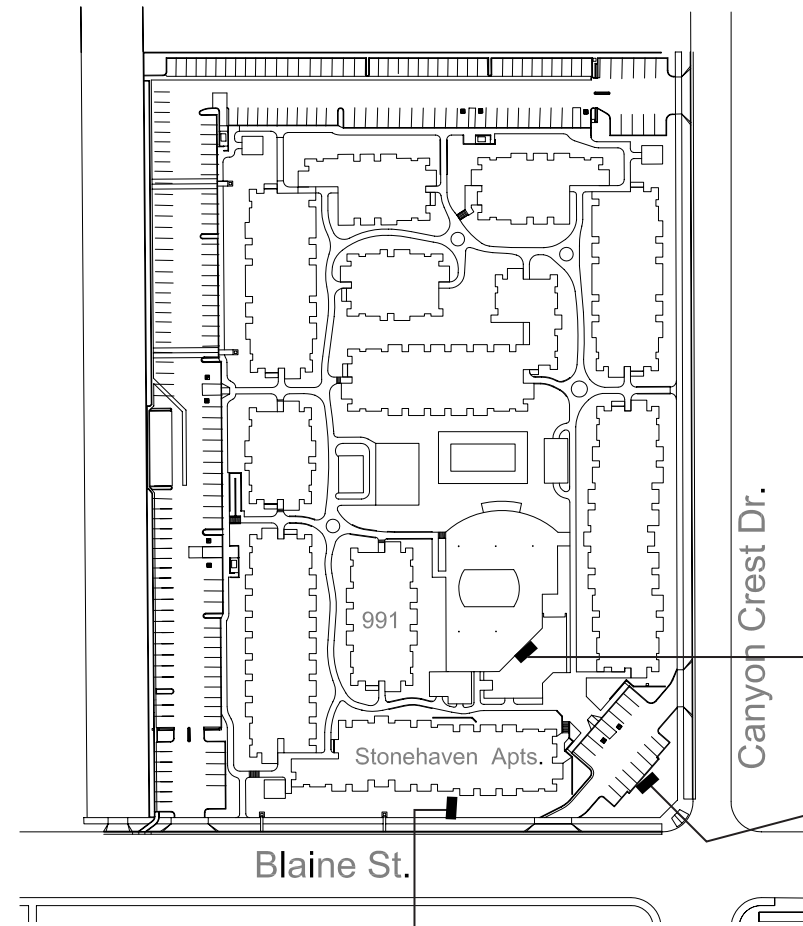

Keep existing sign



Replace with W50 Vehicular Bldg ID

Add W50 Vehicular Bldg Sign

Student Rec Center (511)		qty
W50	Vehicle Bldg ID	0
W51	Freestanding, Ped	0
W52	Wall Mounted	0
W53	Vinyl Letters on Door	0
W54	Parapet Letters	0
B95	Loading Dock ID	0

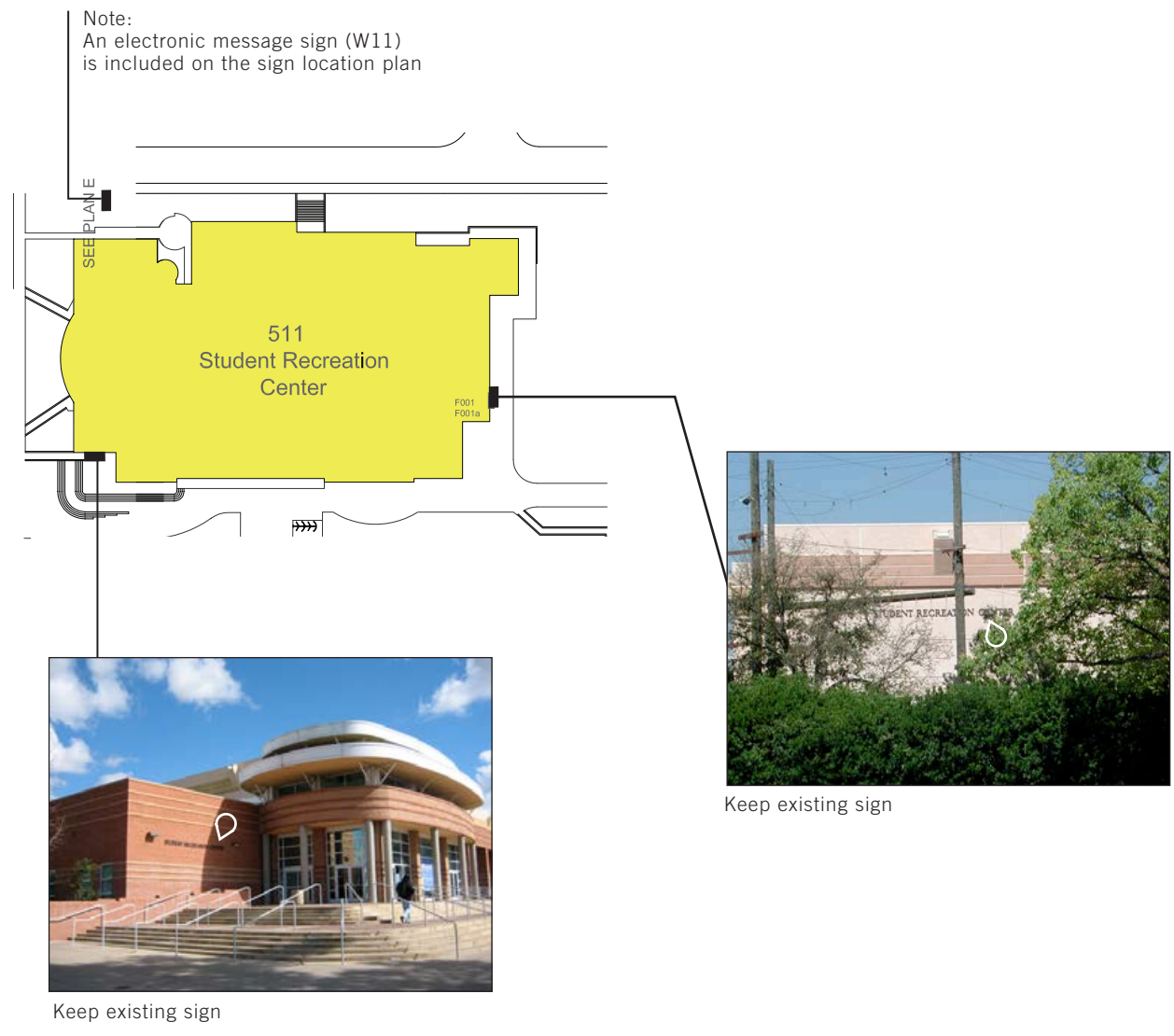

UCR Athletic Complex (285)		qty
W50	Vehicular Bldg ID	1
W51	Freestanding, Ped	2
W52	Wall Mounted	0
W53	Vinyl Letters on Door	0
W54	Parapet Letters	0
B95	Loading Dock ID	0

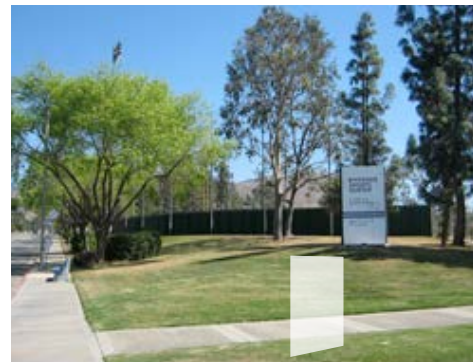

Replace with W50 Vehicular Bldg ID

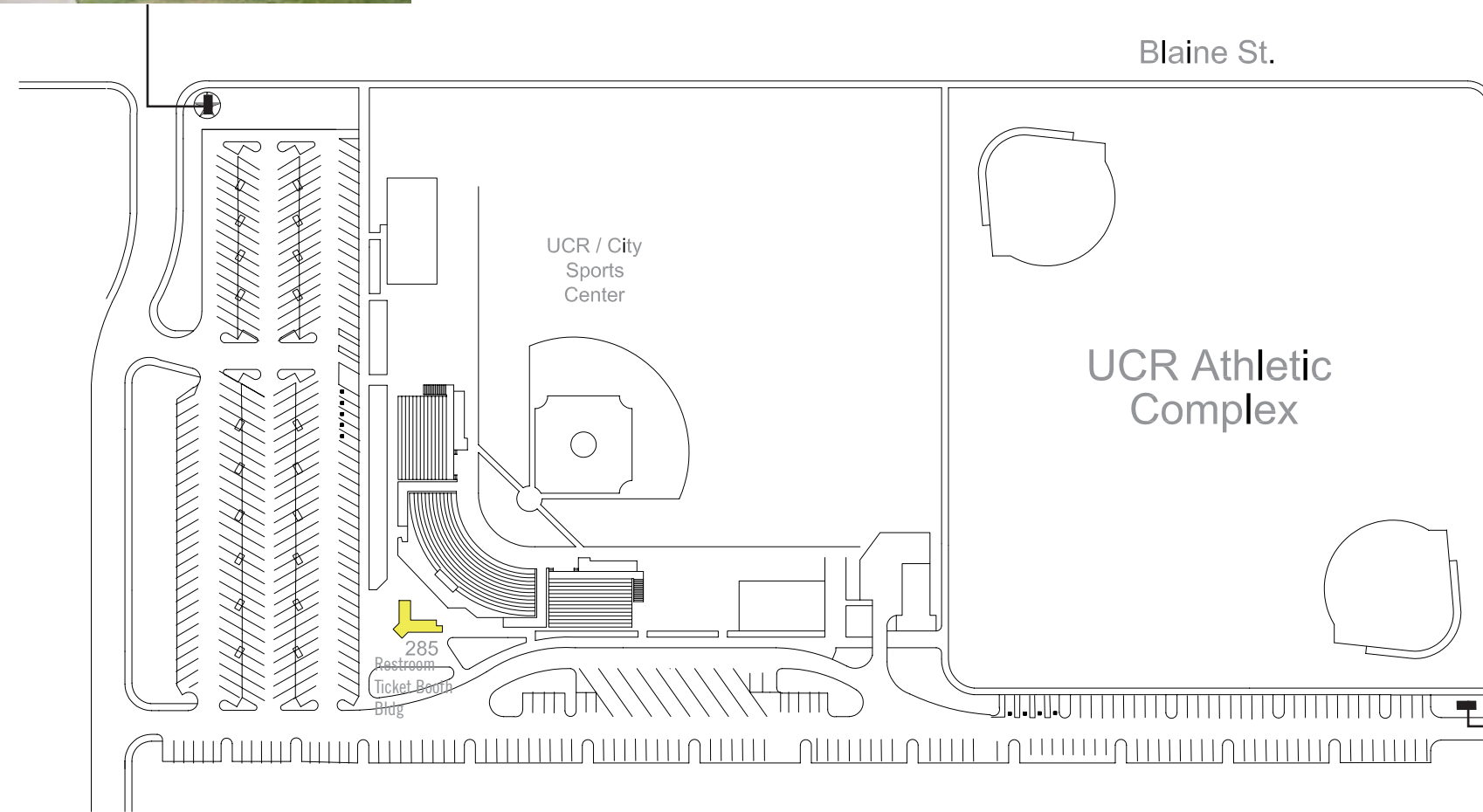

Note:
A Parking Sign (W70)
with the bldg name
has been included
in the sign location plan

UCR Extension Center (722)		qty
W50	Vehicular Bldg ID	1
W51	Freestanding, Ped	0
W52	Wall Mounted	0
W53	Vinyl Letters on Door	1
W54	Parapet Letters	0
B95	Loading Dock ID	0

* Replace Face of large freestanding sign



Keep existing sign



Keep existing sign

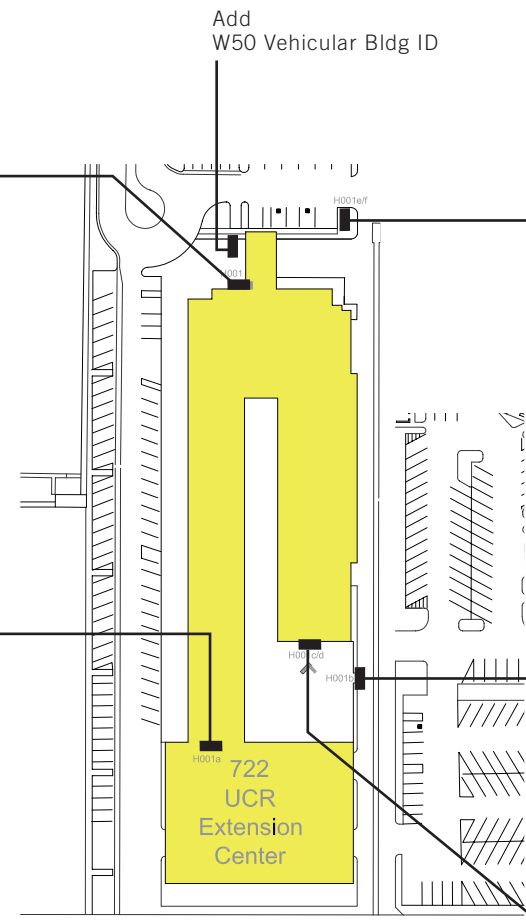

Replace face of sign to match current brand



Keep existing sign



Keep existing sign
Add
W53 Vinyl Letters on Door

University Lab Bldg (263)		qty
W50	Vehicular Bldg ID	1
W51	Freestanding, Ped	0
W52	Wall Mounted	2
W53	Vinyl Letters on Door	0
W54	Parapet Letters	0
B95	Loading Dock ID	0



University Lecture Hall (383)		qty
W50	Vehicular Bldg ID	0
W51	Freestanding, Ped	1
W52	Wall Mounted	4
W53	Vinyl Letters on Door	2
W54	Parapet Letters	0
B95	Loading Dock ID	0



Add
W52 Wall Mounted Bldg ID



Add
W52 Wall Mounted Bldg ID



Add
W52 Wall Mounted Bldg ID



Add
W53 Vinyl Letters on Door



Add
W52 Wall Mounted Bldg ID
W53 Vinyl Letters on Door
W51 Freestanding Bldg ID

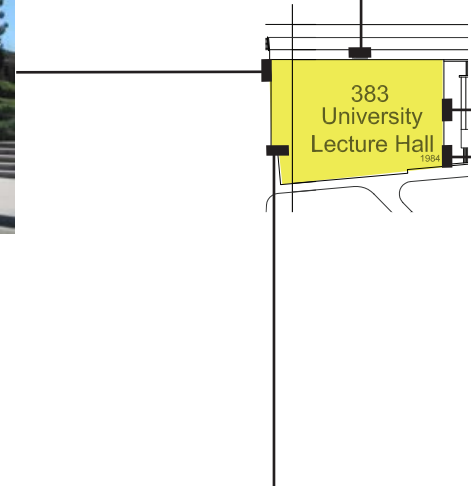

University Office Bldg (205)		qty
W50	Vehicular Bldg ID	1
W51	Freestanding, Ped	0
W52	Wall Mounted	1
W53	Vinyl Letters on Door	0
W54	Parapet Letters	0
B95	Loading Dock ID	0



Keep existing sign



Keep existing sign
Add W53 Vinyl Letters on Door

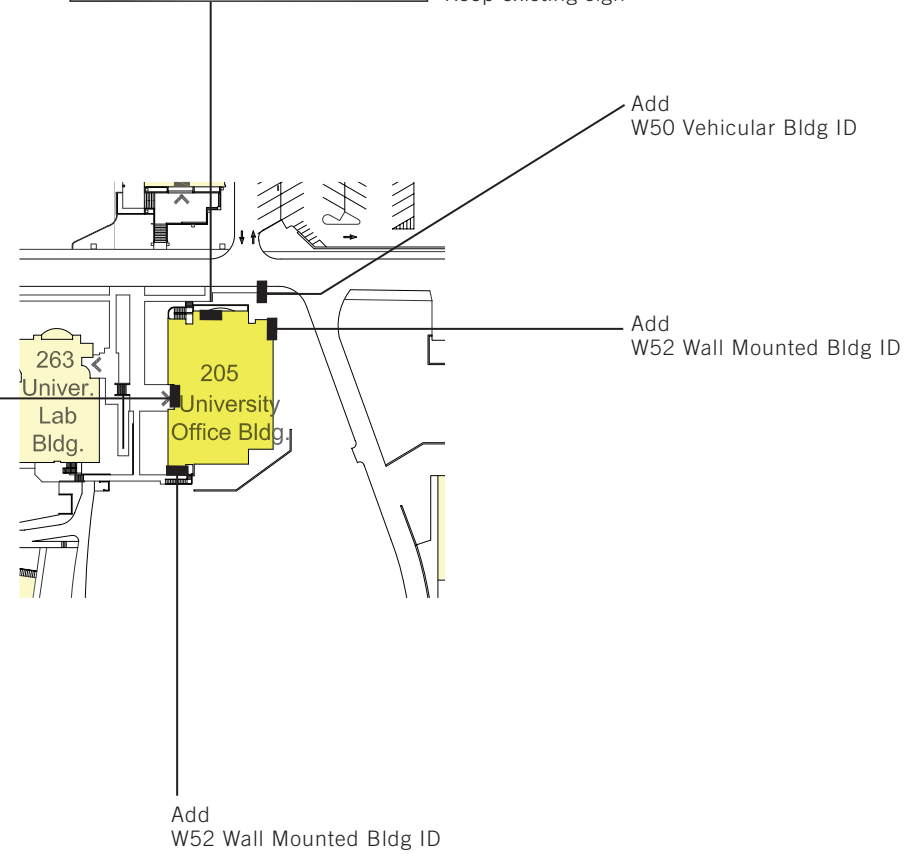

W51	Freestanding, Ped	0
W52	Wall Mounted	0
W53	Vinyl Letters on Door	0
W54	Parapet Letters	0
B95	Loading Dock ID	0

No Signs Recommended at this Time

Not UCR property - Leased

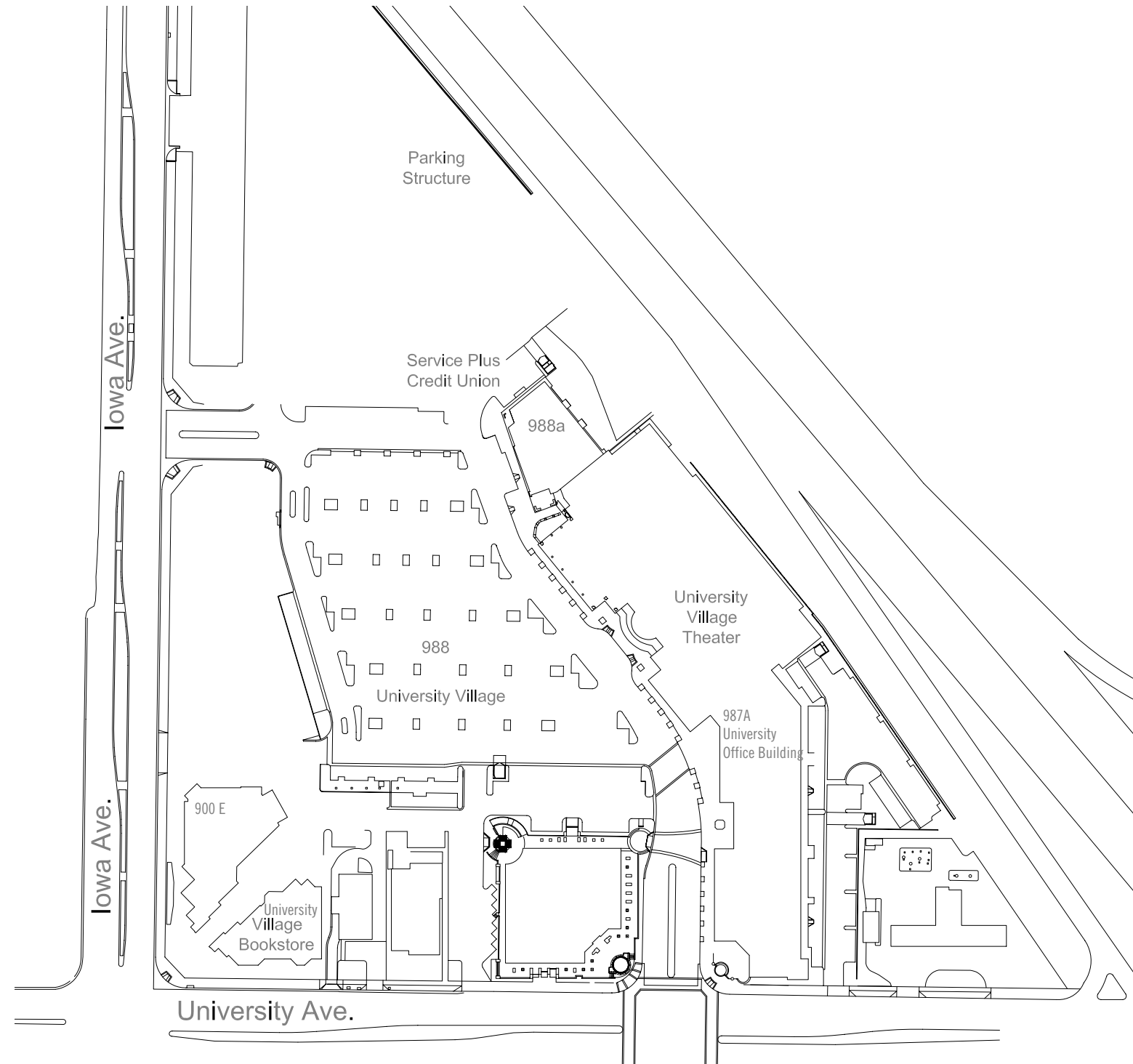

University Plaza Apts. (715)		qty
W50	Vehicular Bldg ID	1
W51	Freestanding, Ped	0
W52	Wall Mounted	0
W53	Vinyl Letters on Door	0
W54	Parapet Letters	0
B95	Loading Dock ID	0

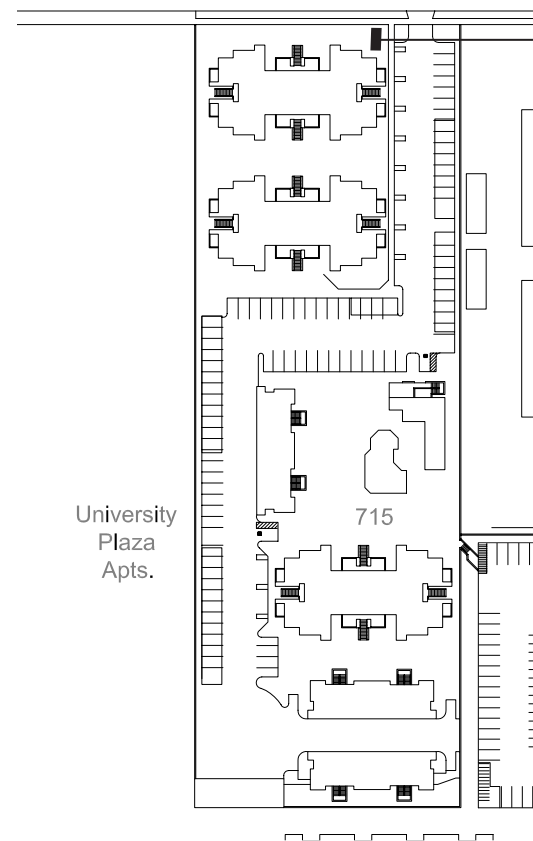

Replace with W50 Vehicular Bldg ID

Watkins Hall (354)

	qty
W50 Vehicular Bldg ID	0
W51 Freestanding, Ped	2
W52 Wall Mounted	6
W53 Vinyl Letters on Door	4
W54 Parapet Letters	0
B95 Loading Dock ID	0



Possible Banner Location



Add W52 Wall Mounted Bldg ID



Possible Banner Location



Add W52 Wall Mounted Bldg ID



Add W51 Freestanding Bldg ID

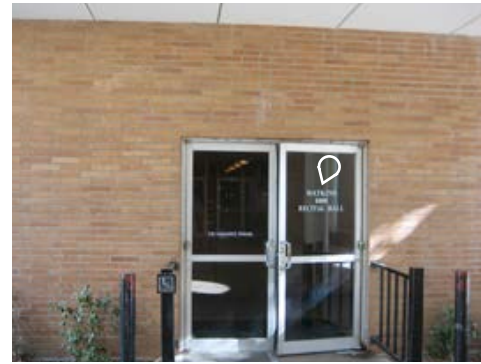

Replace with W53 Vinyl Letters on Door

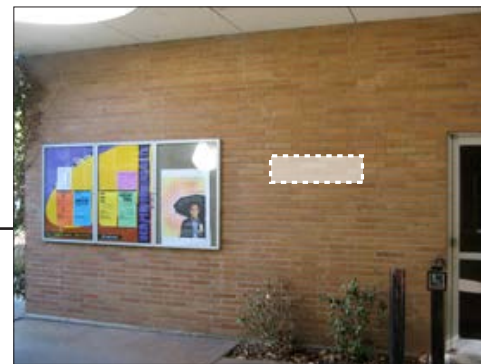

Add W52 Wall Mounted Bldg ID

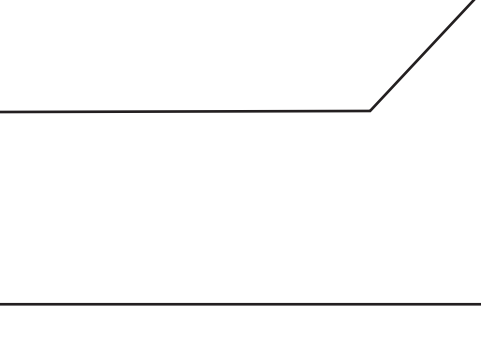
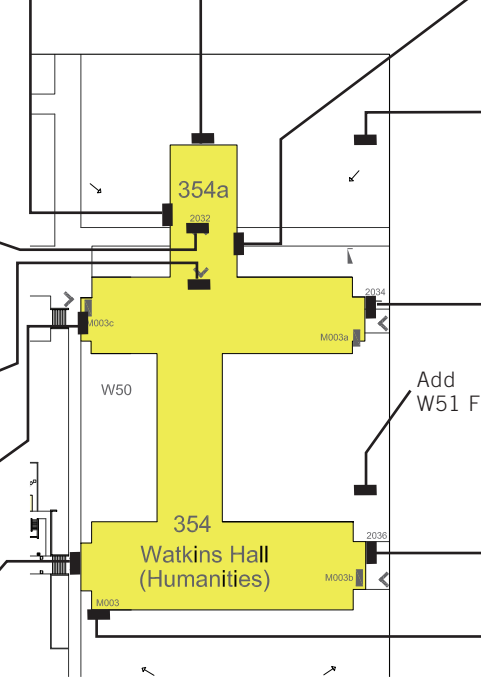

Add W51 Freestanding Bldg ID



Keep existing parapet sign
Add W52 Wall Mounted Bldg



Add W52 Wall Mounted Bldg ID

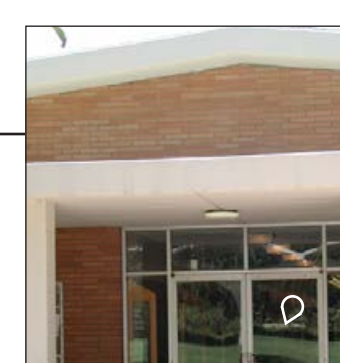
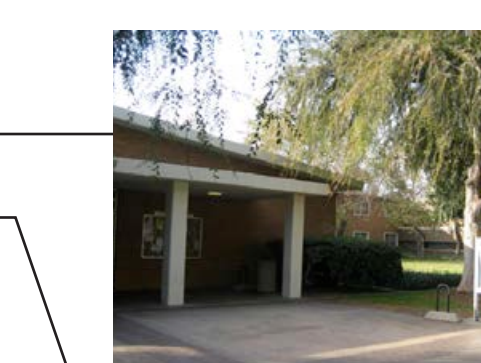

Replace with W53 Vinyl Letters on Door

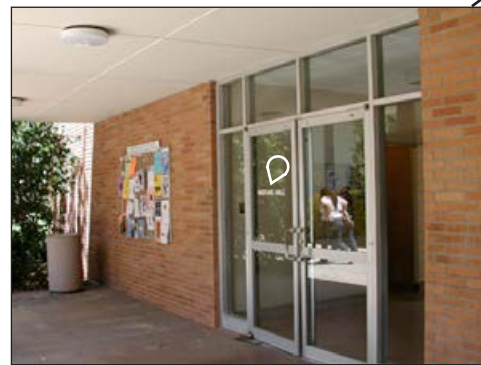

Replace with W53 Vinyl Letters on Door

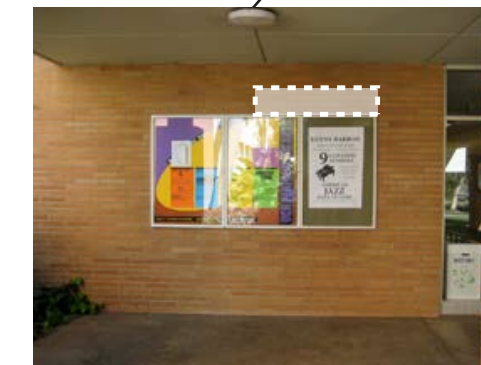

Add W52 Wall Mounted Bldg ID



Replace with W53 Vinyl Letters on Door



Keep existing sign

Webber Hall (342)		qty
W50	Vehicular Bldg ID	0
W51	Freestanding, Ped	1
W52	Wall Mounted	4
W53	Vinyl Letters on Door	4
W54	Parapet Letters	0
B95	Loading Dock ID	0

